

Ridgway Roof Truss Company

(Trusses and Prefabricated Building Components)

Mailing: P.O. Box 1309 – Gainesville, Florida 32602
Physical: 235 SW 11th Place – Gainesville, Florida 32601

Telephone: (352) 376-4436
FAX: (352) 371-3316

Email: Sales@RidgwayTruss.com
www.RidgwayTruss.com

WARNING

**THESE TRUSSES MUST BE
HANDLED AND ERECTED
ACCORDING TO BCSI
SUMMARY SHEETS**

http://www.sbcindustry.docs/06_bcsi_booklet_final.pdf

SEE TABLE OF CONTENTS

DESIGN MANUAL

PROJECT NAME: _____

JOB NUMBER: _____

CONTRACTOR: _____

DATE: _____

REVISIONS: _____

COMMENTS: _____



Lumber design values are in accordance with ANSI/TPI 1-2007 section 6.3
 These truss designs rely on lumber values established by others.

RE: 120440 - ROOF DESIGN INFO

MiTek USA, Inc.

6904 Parke East Blvd.
 Tampa, FL 33610-4115
 Model: -

Site Information:

Customer Info: 84 Lumber Orange Park Project Name: 18 Rosas-Dreambuilders
 Lot/Block: - Subdivision: -
 Address: -
 City: Jacksonville State: FL

Name Address and License # of Structural Engineer of Record, If there is one, for the building.

Name: License #:
 Address: State:
 City:

General Truss Engineering Criteria & Design Loads (Individual Truss Design Drawings Show Special Loading Conditions):

Design Code: FBC2010 Design Program: OnLine Plus 30.0.011
 Wind Code: ASCE 7-10 Wind Speed: 130 mph Floor Load: N/A psf
 Roof Load: 37.0 psf

This package includes 56 individual, dated Truss Design Drawings and 0 Additional Drawings.
 With my seal affixed to this sheet, I hereby certify that I am the Truss Design Engineer and this index sheet conforms to 61G15-31.003, section 5 of the Florida Board of Professional Engineers Rules.

No.	Seal#	Truss Name	Date	No.	Seal#	Truss Name	Date
1	T4462830	R1	7/18/012	18	T4462847	R20	7/18/012
2	T4462831	R2	7/18/012	19	T4462848	R21	7/18/012
3	T4462832	R3	7/18/012	20	T4462849	R22	7/18/012
4	T4462833	R4	7/18/012	21	T4462850	R23	7/18/012
5	T4462834	R5	7/18/012	22	T4462851	R23A	7/18/012
6	T4462835	R6	7/18/012	23	T4462852	R32	7/18/012
7	T4462836	R7	7/18/012	24	T4462853	R33	7/18/012
8	T4462837	R8	7/18/012	25	T4462854	R34	7/18/012
9	T4462838	R9	7/18/012	26	T4462855	R35	7/18/012
10	T4462839	R12	7/18/012	27	T4462856	R36	7/18/012
11	T4462840	R13	7/18/012	28	T4462857	R37	7/18/012
12	T4462841	R14	7/18/012	29	T4462858	R38	7/18/012
13	T4462842	R15	7/18/012	30	T4462859	R39	7/18/012
14	T4462843	R16	7/18/012	31	T4462860	R40	7/18/012
15	T4462844	R17	7/18/012	32	T4462861	R41	7/18/012
16	T4462845	R18	7/18/012	33	T4462862	R42	7/18/012
17	T4462846	R19	7/18/012	34	T4462863	R43	7/18/012

The truss drawing(s) referenced above have been prepared by MiTek Industries, Inc. under my direct supervision based on the parameters provided by Ridgway Roof Trusses.

Truss Design Engineer's Name: Magid, Michael
 My license renewal date for the state of Florida is February 28, 2013.

NOTE: The seal on these drawings indicate acceptance of professional engineering responsibility solely for the truss components shown. The suitability and use of this component for any particular building is the responsibility of the building designer, per ANSI/TPI-1 Sec. 2.

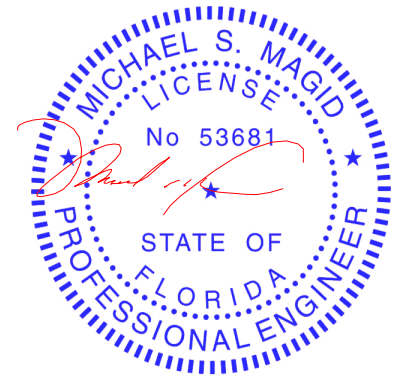

FL Cert. 6634

July 18, 2012

RE: 120440 - ROOF DESIGN INFO

Site Information:

Customer Info: 84 Lumber Orange Park Project Name: 18 Rosas-Dreambuilders Model: -
Lot/Block: - Subdivision: -
Address: -
City: Jacksonville State: FL

No.	Seal#	Truss Name	Date
35	T4462864	R44	7/18/012
36	T4462865	R45	7/18/012
37	T4462866	R46	7/18/012
38	T4462867	R47	7/18/012
39	T4462868	R48	7/18/012
40	T4462869	R49	7/18/012
41	T4462870	R50	7/18/012
42	T4462871	R51	7/18/012
43	T4462872	R52	7/18/012
44	T4462873	R53	7/18/012
45	T4462874	R54	7/18/012
46	T4462875	R55	7/18/012
47	T4462876	T1	7/18/012
48	T4462877	T1A	7/18/012
49	T4462878	T1B	7/18/012
50	T4462879	T2	7/18/012
51	T4462880	T2A	7/18/012
52	T4462881	V1	7/18/012
53	T4462882	V2	7/18/012
54	T4462883	V3	7/18/012
55	T4462884	V4	7/18/012
56	T4462885	V5	7/18/012

Table of Contents

1. General Notes

**2. WTCA 1-1995 (Standard Responsibilities
in the Design Process involving Metal
Plate Connected Wood Trusses)**

3. Engineering (insert)

4. Layout of Truss Placement Plan (insert)

**5. Jobsite Package w/ BCSI B-1, B-2, B-3
and B-4(Handling, Installing and Bracing
Information)**

http://www.sbcindustry.com/docs/06_bcsi_booklet_final.pdf

6. Standard Chord and Web Repairs

7. Examples of Permanent Web Bracing

ROBBINS ENG. GENERAL NOTES & SYMBOLS

PLATE LOCATION

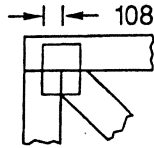

Center plates on joints unless otherwise noted in plate list or on drawing. Dimensions are given in inches (i.e. 1 1/2" or 1.5") or IN-16ths (i.e. 108).

PLATE SIZE

6.3 x 8.8

The first dimension is the width measured perpendicular to slots. The second dimension is the length measured parallel to slots.

LATERAL BRACING

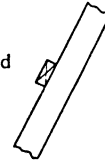

1x4 continuous lateral bracing attached with (2) 8d nails each member where indicated or 2x4 "T" or "L" brace stiffener if applicable nailed flat to edge of web with 12d nails spaced 8" o.c. "T" or "L" brace must be extended at least 90% of web length.

PLATE ORIENTATION



When shown, indicates direction of slots in connector plate.

DIMENSIONS

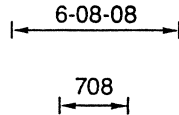

All dimensions are shown in FT-IN-SX (i.e. 6' 8 1/2" or 6-08-08). Dimensions less than one foot are shown in IN-SX only (i.e. 708).

BEARING

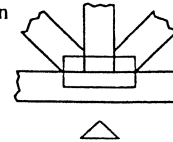

When truss is designed to bear on multiple supports, interior bearing locations should be marked on the truss. Interior support or temporary shoring must be in place before erecting this truss. If necessary, shim bearings to assure solid contact with truss.

ROBBINS LOCK connector plates (20 ga. galv. steel ASTM A653 SS Grade 40) shall be applied on both faces of truss at each joint. Center the plates, unless shown otherwise by circles (o) or dimensions. No loose knots or wanes in plate contact area. Splice only where shown. Overall spans assume 4" bearings at each end, unless indicated otherwise. Cutting and fabrication shall be performed on equipment which produces snug-fitting joints and plates. Unless otherwise noted, moisture content of lumber shall not exceed 19% at time of fabrication and these designs are not applicable for use with fire retardant lumber. This design was prepared in accordance with "National Design Specifications for Stress - Grade Lumber and Its Fastenings" (AFPA), "Design Specifications for Light Metal Plate Connected Wood Trusses" (TPI), and HUD Design Criteria for

Trussed Rafters. Robbins Eng. Co. bears no responsibility for the erection of trusses, field bracing or permanent truss bracing. Refer to HIB-91 as published by the Truss Plate Institute, 583 D'Onofrio Drive, Suite 200, Madison, Wisconsin 53719. Persons erecting trusses are cautioned to seek professional advice concerning proper erection bracing to prevent toppling and "dominoing". Care should be taken to prevent damage during fabrication, storage, shipping and erection. Top and bottom chords shall be adequately braced in the absence of sheathing or rigid ceiling, respectively. It is the responsibility of others to ascertain that the design loads utilized on this drawing meet or exceed the actual dead loads imposed by the structure and the live loads imposed by the local building code or historical climatic records.

FURNISH A COPY OF THIS DESIGN TO ERECTION CONTRACTOR. IT IS THE RESPONSIBILITY OF BUILDING DESIGNER TO REVIEW THIS DRWG. & VERIFY THAT DATA INCLUDING DIM. & LOADS CONFORM TO ARCH. PLAN/SPECS & FAB. TRUSS LAYOUTS.



CORPORATE HEADQUARTERS

P.O. Box 280055
Tampa, FL 33682-0055
800-282-1299 • Fax: 813-971-6117



Wood Truss Council of America

5937 Meadowood Dr., Ste. 14 • Madison, WI 53711-4125 • 608/274-3329 (fax)

**Standard Responsibilities
in the Design Process
Involving Metal Plate
Connected Wood Trusses**

WTCA 1-1995

Developed by the WTCA Engineering Review Committee
in cooperation with the Truss Plate Institute

The Wood Truss Council of America publishes standard practice materials prepared and edited by knowledgeable authors from the construction industry to give as much assistance as possible to owners, architects, engineers, contractors, building officials, and others involved in the metal plate connected wood truss industry. The competence of the authors ensures accurate and authoritative information in regard to the subject matter covered, but, of course, neither the Wood Truss Council of America, nor the authors make either express or implied warranties in regard to the use of the materials.

1.0 SCOPE AND DEFINITIONS

- 1.1 This standard defines the design responsibilities of the individuals and organizations involved in the preparation, submittal, review and approval of each Truss Design Drawing and Truss Placement Plan associated with the use of metal plate connected wood trusses. These guidelines are presented as industry standard practice. The guidelines are not intended to preclude alternate provisions as agreed upon by the parties involved.
- 1.2 The following definitions shall apply:
- 1.2.1 “Architect” shall mean the individual registered architect responsible for the architectural design of the structure and who produces the architectural drawings included in the Construction Design Documents.
- 1.2.2 “Building Designer” is the individual or organization having responsibility for the overall building or structure design in accordance with the state’s statutes and regulations governing the professional registration and certification of architects or engineers. This responsibility includes but is not limited to foundation design, structural member sizing, load transfer, bearing conditions, and the structure’s compliance with the applicable building codes. Also referred to as registered architect or engineer, building designer, and registered building designer, but hereinafter will be referred to as Building Designer.
- 1.2.3 “Construction Design Documents” are the architectural drawings, structural drawings, mechanical drawings, electrical drawings, and any other drawings, specifications, and addenda which set forth the overall design of the structure and issued by the Building Designer.
- 1.2.4 “Contractor” shall mean the individual or organization responsible for the field storage, handling, and installation of trusses including, but not limited to, temporary bracing, permanent bracing, anchorage, connections and field assembly. The term “Contractor” shall include those subcontractors who have a direct contract with the Contractor to perform all or a portion of the storage, handling, and installation of the trusses.
- 1.2.5 “Engineer-of-Record” shall mean the registered professional engineer responsible for the structural design of the structure and who produces the structural drawings included in the Construction Design Documents.
- 1.2.6 “Owner” shall mean the individual or organization for whom the structure is designed.
- 1.2.7 “Truss” is an individual metal plate connected wood structural component manufactured by the Truss Manufacturer.
- 1.2.8 “Truss Designer” is the design professional, individual or organization, having responsibility for the design of metal plate connected wood trusses. This responsibility shall be in accordance with the state’s statutes and regulations governing the professional registration and certification of architects or engineers. Also referred to as truss engineer, design engineer, registered engineer, and engineer, but hereinafter will be referred to as Truss Designer.
- 1.2.9 “Truss Design Drawing” shall mean the graphic depiction of an individual Truss prepared by the Truss Designer.
- 1.2.10 “Truss Manufacturer” shall mean an individual or organization regularly engaged in the manufacturing of Trusses.
- 1.2.11 “Truss Placement Plan” is the drawing identifying the location assumed for each Truss based on the Truss Manufacturer’s interpretation of the Construction Design Documents.

2.0 OWNER RESPONSIBILITIES

- 2.1 Directly or through its representatives, which may include the Contractor and/or Building Designer; (a) review and approve each Truss Design Drawing; (b) review and approve the Truss Placement Plan; (c) resolve and approve all design issues arising out of the preparation of each Truss Design Drawing and Truss Placement Plan; and (d) coordinate the return of each approved Truss Design Drawing and Truss Placement Plan to the Truss Manufacturer prior to truss manufacturing.

3.0 BUILDING DESIGNER RESPONSIBILITIES

- 3.1 Design a structure suitable to ensure that the intended function of each Truss is not affected by adverse influences including, but not limited to, moisture, temperature, corrosive chemicals and gases;
- 3.2 Prepare the Construction Design Documents, showing all trussed areas, which must provide as a minimum the following:
- 3.2.1 All truss orientations and locations;
 - 3.2.2 Information to fully determine all truss profiles;
 - 3.2.3 Adequate support of the Truss and all truss bearing conditions;
 - 3.2.4 Permanent bracing design for the structure including the Trusses, except as provided in 3.4 and 6.2.12.
 - 3.2.5 The location, direction and magnitude of all dead and live loads applicable to each Truss including, but not limited to, loads attributable to: roof, floor, partition, mechanical, fire sprinkler, attic, storage, wind, snow drift and seismic;
 - 3.2.6 All Truss anchorage designs required to resist uplift, gravity, and lateral loads;
 - 3.2.7 Allowable vertical and horizontal deflection criteria;
- 3.3 Review and approve the Truss Placement Plan and each Truss Design Drawing for conformance with the requirements and intent of the Construction Design Documents, the effect of each Truss Design Drawing and Truss Placement Plan on other parts of the structure, and the effect of the structure on each Truss.
- 3.4 Specify permanent lateral bracing where indicated by the Truss Designer on the Truss Design Drawings, to prevent buckling of the individual truss members due to design loads. The Building Designer shall specify how the permanent lateral bracing is to be anchored or restrained to prevent lateral movement if all truss members, so braced, buckle together. This shall be accomplished by: (a) anchorage to solid end walls; (b) permanent diagonal bracing in the plane of the web members; or (c) other means when demonstrated by the Building Designer to provide equivalent bracing.
- 3.2.8 Proper transfer of design loads affecting the Truss; and
- 3.2.9 Adequate connections between Truss and non-Truss components, except as noted in Section 6.2.9.

4.0 CONTRACTOR RESPONSIBILITIES

- 4.1 Provide to the Truss Manufacturer the Construction Design Documents and all revisions and supplements thereto.
- 4.2 Review and approve the Truss Placement Plan and each Truss Design Drawing for conformance with the requirements and intent of the Construction Design Documents, and the effect of the Truss Placement Plan and each Truss Design Drawing on other trades involved in the construction of the structure and the effect of the other trades on the Trusses.
- 4.3 Coordinate the review, approval and return of each Truss Design Drawing and the Truss Placement Plan by the Owner and Building Designer.
- 4.4 Provide the approved Truss Design Drawings, approved Truss Placement Plans, and any supplemental information provided by the Truss Manufacturer to the individual or organization responsible for the installation of the Trusses.
- 4.5 Comply with the field storage, handling, installation, permanent bracing, anchorage, connections and field assembly requirements of the Construction Design Documents.
- 4.6 Determine and install the temporary bracing for the structure, including the Trusses.

5.0 TRUSS MANUFACTURER RESPONSIBILITIES

- 5.1 Communicate the design criteria from the Construction Design Documents to the Truss Designer.
- 5.2 Where required by the Construction Design Documents, prepare the Truss Placement Plan, providing as a minimum the location assumed for each Truss based on the Truss Manufacturer's interpretation of the Construction Design Documents.
- 5.3 Submit to the Contractor the Truss Placement Plan, as may be required, and each Truss Design Drawing for review and approval.
- 5.4 Manufacture the Trusses in accordance with the final approved Truss Design Drawings using the quality criteria for Metal Plate Connected Wood Trusses established by the ANSI/TPI 1-1995 "National Design Standard for Metal Plate Connected Wood Truss Construction."

6.0 TRUSS DESIGNER RESPONSIBILITIES

- 6.1 Prepare the Truss Design Drawings in conformance with the requirements set forth in the latest approved edition of ANSI/TPI 1-1995 "National Design Standard for Metal Plate Connected Wood Truss Construction."
- 6.2 For each Truss Design Drawing, set forth as a minimum the following:
 - 6.2.1 Slope or depth, span and spacing;
 - 6.2.2 Location of all joints;
 - 6.2.3 Required bearing widths;
 - 6.2.4 Design loads as applicable:
 - 6.2.4.1 Top chord live load (including snow loads);
 - 6.2.4.2 Top chord dead load;
 - 6.2.4.3 Bottom chord live load;
 - 6.2.4.4 Bottom chord dead load;
 - 6.2.4.5 Concentrated loads and their points of application; and
 - 6.2.4.6 Controlling wind and earthquake loads;
 - 6.2.5 Adjustments to lumber and metal connector plate design values for conditions of use;
 - 6.2.6 Each reaction force and direction;
 - 6.2.7 Metal connector plate type, size, thickness or gage, and the dimensioned location of each metal connector plate except where symmetrically located relative to the joint interface;
 - 6.2.8 Lumber size, species, and grade for each member;
 - 6.2.9 Connection Requirements for:
 - (a) Truss to Truss girder;
 - (b) Truss ply to ply; and
 - (c) Field splices;
 - 6.2.10 Calculated deflection ratio and/or maximum deflection for live and total load;
 - 6.2.11 Maximum axial compression forces in the Truss members to enable the Building Designer to design the size, connections and anchorage of the permanent continuous lateral bracing. Forces may be shown on the Truss Design Drawing or on supplemental documents; and
 - 6.2.12 Required permanent Truss member bracing location.

7.0 OTHER RESPONSIBILITIES

- 7.1 Any party who cuts or damages a truss shall be responsible for securing the engineering required for the repair and for subsequent costs.

Wood Truss Council of America's Objective

WTCA is committed to promoting the common interests of all engaged in the manufacture of wood trusses and related components to ensure growth, continuity, and increased professionalism in our industry. Fundamental to this is promoting the safe, economic, and structurally sound use of trusses in all applications.

18- Rosas- Dreambuilders

HO 2-12

HO 3-14

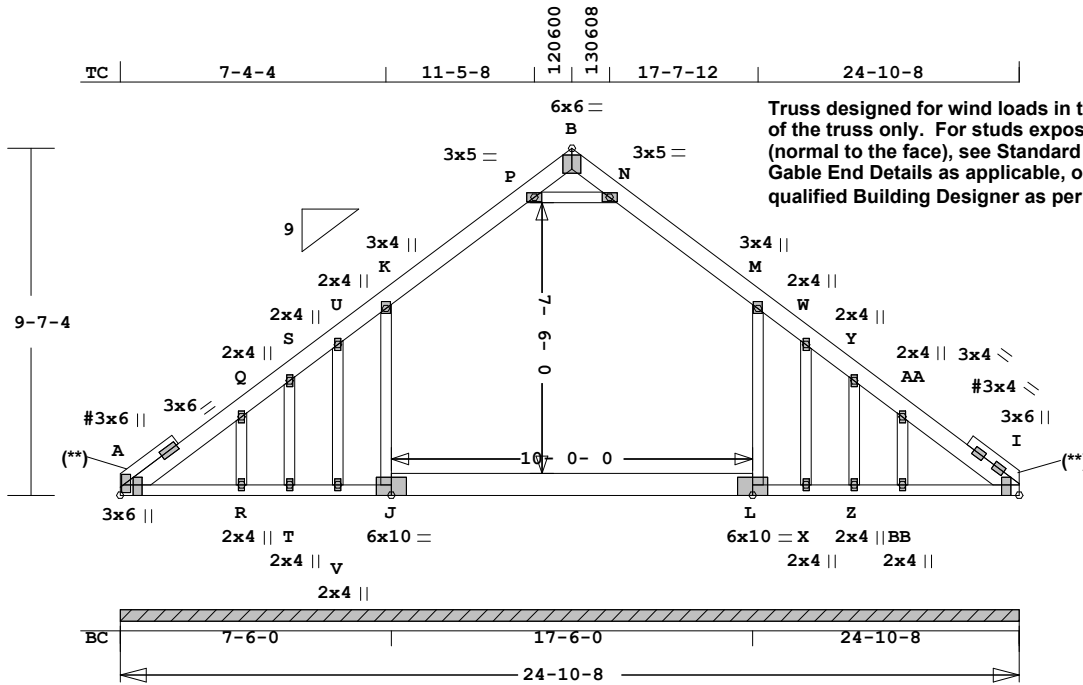

ALL PLATES ARE MT2020, # = PLATE SELECTED IN PLATE MONITOR

Scale: 0.188" = 1'

MiTek® Online Plus™ APPROX. TRUSS WEIGHT: 218.3 LBS

Online Plus -- Version 30.0.011
RUN DATE: 18-JUL-12

Southern Pine lumber design values are those effective 06-01-12 by SPIB//ALSC UON
CSI -Size- ---Lumber---
TC 0.04 2x 6 SP-#2
BC 0.69 2x 4 SP-#1
-- 0.32 2x 8 SP-2400f-2.0E
J -L
WB 0.17 2x 4 SP-#3
GW 0.04 2x 4 SP-#3
ACT 0.08 2x 4 SP-#3
(**) 2x4 SP-#2

Brace truss as follows:
O.C. From To
TC Cont. 0- 0- 0 24-10- 8
or 48.0" 0- 0- 0 24-10- 8
BC Cont. 0- 0- 0 24-10- 8
or 72.0" 0- 0- 0 24-10- 8
Cont. Attic Chords (Top)
or 29.7" Attic Chords (Top)

psf-Ld	Dead	Live		
TC	7.0	20.0		
BC	10.0	0.0		
TC+BC	17.0	20.0		
Total	37.0	Spacing 24.0"		
Lumber	Duration Factor	1.25		
Plate	Duration Factor	1.25		
	Fb	Fc	Ft	Emin
TC	1.15	1.10	1.10	1.10
BC	1.10	1.10	1.10	1.10

Total Load Reactions (Lbs)
Jt Down Uplift Horiz-
A 2928 218 U 185 R

Jt Brg Size Required
A 298.5" 0"-to- 299"

LC#	1	Attic Loading
Dur Fctrs	- Lbr	1.25 Plt 1.25
plf	- Dead	Live* From To
TC V	14	40 0.0' 24.9'
BC V	20	0 0.0' 24.9'
TC V	10	0 7.5' 11.3'
TC V	10	0 13.7' 17.5'
BC V	10	80 7.5' 17.5'
MA V	10	0 11.5' 13.5'
WB S	10	0 K J
WB S	10	0 M L

Plus 21 Wind Load Case(s)
Plus 1 UBC LL Load Case(s)
Plus 1 DL Load Case(s)
Plus 1 Attic 2 Load Case(s)

Membr	CSI	P	Lbs	Axl	CSI-Bnd
-----Top Chords-----					
A -Q	0.03		349 C	0.00	0.03
Q -S	0.02		351 C	0.00	0.02
S -U	0.01		333 C	0.00	0.01
U -K	0.04		319 C	0.00	0.04
K -P	0.04		340 C	0.00	0.04
P -B	0.03		45 C	0.00	0.03
B -N	0.03		45 C	0.00	0.03
N -M	0.04		340 C	0.00	0.04
M -W	0.04		319 C	0.00	0.04
W -Y	0.01		333 C	0.00	0.01
Y -AA	0.02		350 C	0.00	0.02
AA -I	0.02		350 C	0.00	0.02

-----Bottom Chords-----					
A -R	0.02		71 C	0.00	0.02
R -T	0.02		0 T	0.00	0.02
T -V	0.07		0 T	0.00	0.07
V -J	0.69		0 T	0.00	0.69
J -L	0.32		0 T	0.00	0.32
L -X	0.69		0 T	0.00	0.69
X -Z	0.07		0 T	0.00	0.07
Z -BB	0.02		0 T	0.00	0.02
BB -I	0.02		56 C	0.00	0.02

-----Webs-----					
J -K	0.17		244 C		
L -M	0.17		244 C		

-----Gable Webs-----					
R -Q	0.04		166 C		
T -S	0.01		54 C		
V -U	0.02		59 C		
X -W	0.02		59 C		
Z -Y	0.01		54 C		
BB-AA	0.04		164 C		

-----Attic Chords (Top)-----

P -N	0.08		298 C		
------	------	--	-------	--	--

TL Defl -0.20" in J -L L/999
LL Defl -0.16" in J -L L/999
Shear // Grain in V -J 0.65

Plates for each ply each face.
Plate - MT20 20 Ga, Gross Area
Plate - MT2H 20 Ga, Gross Area
Plate - MS18 20 Ga, Gross Area
Jt Type Plt Size X Y JSI
A MT20 3.0x 6.0 0.2-0.5 0.48
Q MT20 2.0x 4.0 Ctr Ctr 0.31
S MT20 2.0x 4.0 Ctr Ctr 0.27
U MT20 2.0x 4.0 Ctr Ctr 0.33
K MT20 3.0x 4.0 Ctr 0.3 0.19
P MT20 3.0x 5.0-0.1 Ctr 0.13
B MT20 6.0x 6.0 Ctr-1.8 0.33
N MT20 3.0x 5.0 0.1 Ctr 0.13
M MT20 3.0x 4.0 Ctr 0.3 0.19
W MT20 2.0x 4.0 Ctr Ctr 0.33
Y MT20 2.0x 4.0 Ctr Ctr 0.27

AA	MT20	2.0x 4.0	Ctr Ctr	0.31
I	MT20	3.0x 6.0	Ctr-0.5	0.48
R	MT20	2.0x 4.0	Ctr Ctr	0.30
T	MT20	2.0x 4.0	Ctr Ctr	0.34
V	MT20	2.0x 4.0	Ctr Ctr	0.34
J	MT20	6.0x10.0	Ctr	1.2 0.93
L	MT20	6.0x10.0	Ctr	1.2 0.93
X	MT20	2.0x 4.0	Ctr Ctr	0.34
Z	MT20	2.0x 4.0	Ctr Ctr	0.34
BB	MT20	2.0x 4.0	Ctr Ctr	0.30

REVIEWED BY:
MiTek Industries, Inc.
6904 Parke East Blvd.
Tampa, FL 33610

REFER TO ONLINE PLUS GENERAL NOTES AND SYMBOLS SHEET FOR ADDITIONAL SPECIFICATIONS.

NOTES:
Trusses Manufactured by:
RIDGWAY ROOF TRUSS

Analysis Conforms To:

FBC2010
TPI 2007
Design checked for 10 psf non-concurrent LL on BC.

NOTE: USER MODIFIED PLATES
This design may have plates selected through a plate monitor.
Partial-length live loads checked.

Wind Loads - ANSI / ASCE 7-10
Truss is designed as

Components and Claddings* for Exterior zone location.
Wind Speed: 130 mph
Risk Category : II
Mean Roof Height: 25-0
Exposure Category: B
Building Type: Enclosed
TC Dead Load: 4.0 psf
BC Dead Load: 6.0 psf
Max comp. force 351 Lbs
Max tens. force 182 Lbs
Connector Plate Fabrication Tolerance = 20%

This truss is designed for a creep factor of 1.5 which is used to calculate total load deflection.

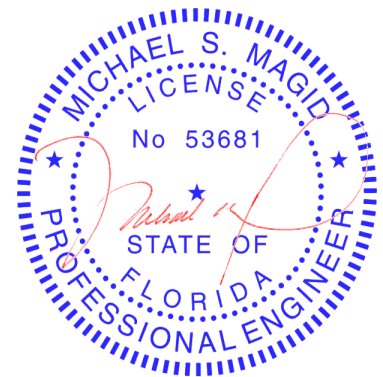

FL Cert. 6634

July 18, 2012

Job 120440	Mark R2	Quan 5	Type TR	Span 241008	Pl-H1 9	Left OH 0	Right OH 0	Engineering T4462831
----------------------	-------------------	-----------	------------	----------------	------------	--------------	---------------	-------------------------

18- Rosas- Dreambuilders

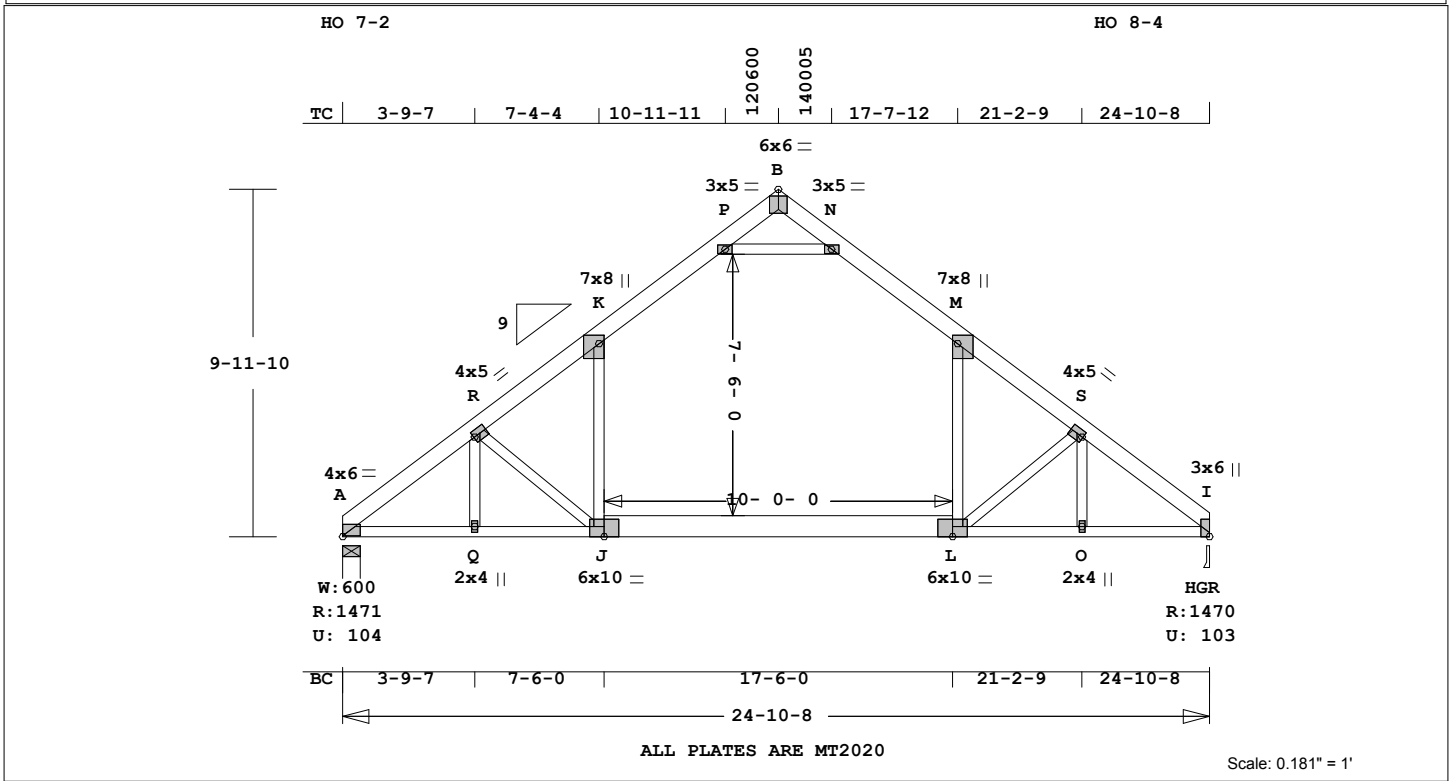

MiTek® Online Plus™ APPROX. TRUSS WEIGHT: 208.8 LBS

Online Plus -- Version 30.0.011
RUN DATE: 18-JUL-12

Southern Pine lumber design values are those effective 06-01-12 by SPIB//ALSC UON
CSI -Size- Lumber-
TC 0.53 2x 6 SP-2400f-2.0E
BC 0.83 2x 4 SP-#2
-- 0.46 2x 8 SP-2400f-2.0E
J -L
WB 0.43 2x 4 SP-#3
ACT 0.74 2x 4 SP-#3

Brace truss as follows:
O.C. From To
TC Cont. 0- 0- 0 24-10- 8
or 48.0" 0- 0- 0 24-10- 8
BC Cont. 0- 0- 0 24-10- 8
or 120.0" 0- 0- 0 24-10- 8
Cont. Attic Chords (Top)
or 36.0" Attic Chords (Top)

psf-Ld Dead Live
TC 7.0 20.0
BC 10.0 0.0
TC+BC 17.0 20.0
Total 37.0 Spacing 24.0"
Lumber Duration Factor 1.25
Plate Duration Factor 1.25
Fb Fc Ft Emin
TC 1.15 1.10 1.10 1.10
BC 1.10 1.10 1.10 1.10

Total Load Reactions (Lbs)
Jt Down Uplift Horiz-
A 1472 105 U 189 R
I 1470 103 U 188 R

Jt Brg Size Required
A 6.0" 1.7"
I 3.5" 1.7"

LC# 1 Attic Loading
Dur Fctrs - Lbr 1.25 Plt 1.25
plf - Dead Live* From To
TC V 14 40 0.0' 24.9'
BC V 20 0 0.0' 24.9'
TC V 10 0 7.5' 10.8'
TC V 10 0 14.2' 17.5'
BC V 10 80 7.5' 17.5'
MA V 10 0 11.0' 14.0'
WB S 10 0 K J
WB S 10 0 M L

Plus 21 Wind Load Case(s)
Plus 2 Unbalanced Load Cases
Plus 1 UBC LL Load Case(s)
Plus 1 DL Load Case(s)
Plus 1 Attic 2 Load Case(s)

Membr	CSI	P Lbs	Axl	CSI-Bnd
-----Top Chords-----				
A -R	0.10	2076 C	0.00	0.10
R -K	0.53	1914 C	0.00	0.53
K -P	0.52	1202 C	0.00	0.52
P -B	0.46	703 T	0.03	0.43
B -N	0.46	701 T	0.03	0.43
N -M	0.51	1205 C	0.00	0.51
M -S	0.52	1906 C	0.00	0.52
S -I	0.12	2050 C	0.00	0.12
-----Bottom Chords-----				
A -Q	0.61	1644 T	0.35	0.26
Q -J	0.80	1646 T	0.29	0.51
J -L	0.46	1337 T	0.04	0.42
L -O	0.83	1614 T	0.29	0.54
O -I	0.64	1612 T	0.34	0.30
-----Webs-----				
Q -R	0.03	106 C		
R -J	0.20	455 C		
J -K	0.43	1070 T		
L -M	0.42	1055 T		
L -S	0.18	419 C		
O -S	0.03	118 C		
-----Attic Chords (Top)-----				
P -N	0.74	2215 C		

TL Defl -0.70" in J -L L/414
LL Defl -0.43" in J -L L/679
Shear // Grain in K -P 0.54

Plates for each ply each face.
Plate - MT20 20 Ga, Gross Area
Plate - MT2H 20 Ga, Gross Area
Plate - MS18 18 Ga, Gross Area
Jt Type Plt Size X Y JSI
A MT20 4.0x 6.0 0.8 0.5 0.65
R MT20 4.0x 5.0 Ctr Ctr 0.32
K MT20 7.0x 8.0-1.8-1.1 0.43
P MT20 3.0x 5.0-0.1 Ctr 0.64
B MT20 6.0x 6.0 Ctr-1.8 0.33
N MT20 3.0x 5.0 0.1 Ctr 0.64
M MT20 7.0x 8.0 1.8-1.1 0.43
S MT20 4.0x 5.0 Ctr Ctr 0.32
I MT20 3.0x 6.0-0.1 0.6 0.86
Q MT20 2.0x 4.0 Ctr Ctr 0.34
J MT20 6.0x10.0 Ctr 1.2 0.53
L MT20 6.0x10.0 Ctr 1.2 0.56
O MT20 2.0x 4.0 Ctr Ctr 0.34

REVIEWED BY:
MiTek Industries, Inc.
6904 Parke East Blvd.
Tampa, FL 33610

REFER TO ONLINE PLUS GENERAL NOTES AND SYMBOLS SHEET FOR ADDITIONAL SPECIFICATIONS.

NOTES:

Trusses Manufactured by:
RIDGWAY ROOF TRUSS
Analysis Conforms To:
FBC2010
TPI 2007
Design checked for 10 psf non-concurrent LL on BC.
Partial-length live loads checked.
Wind Loads - ANSI / ASCE 7-10
Truss is designed as
Components and Claddings* for Exterior zone location.
Wind Speed: 130 mph
Risk Category : II
Mean Roof Height: 25-0
Exposure Category: B
Building Type: Enclosed
TC Dead Load: 4.0 psf
BC Dead Load: 6.0 psf
Max comp. force 2215 Lbs
Max tens. force 1646 Lbs
Connector Plate Fabrication
Tolerance = 20%
This truss is designed for a creep factor of 1.5 which is used to calculate total load deflection.

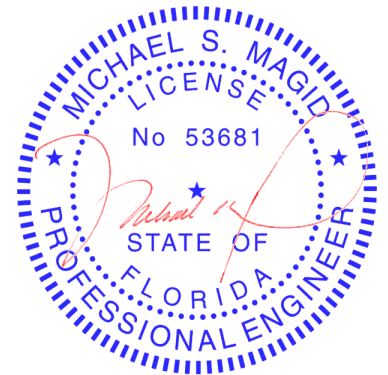

FL Cert. 6634

Job 120440	Mark R3	Quan 6	Type TR	Span 241008	Pl-H1 9	Left OH 0	Right OH 0	Engineering T4462832
----------------------	-------------------	-----------	------------	----------------	------------	--------------	---------------	-------------------------

18- Rosas- Dreambuilders

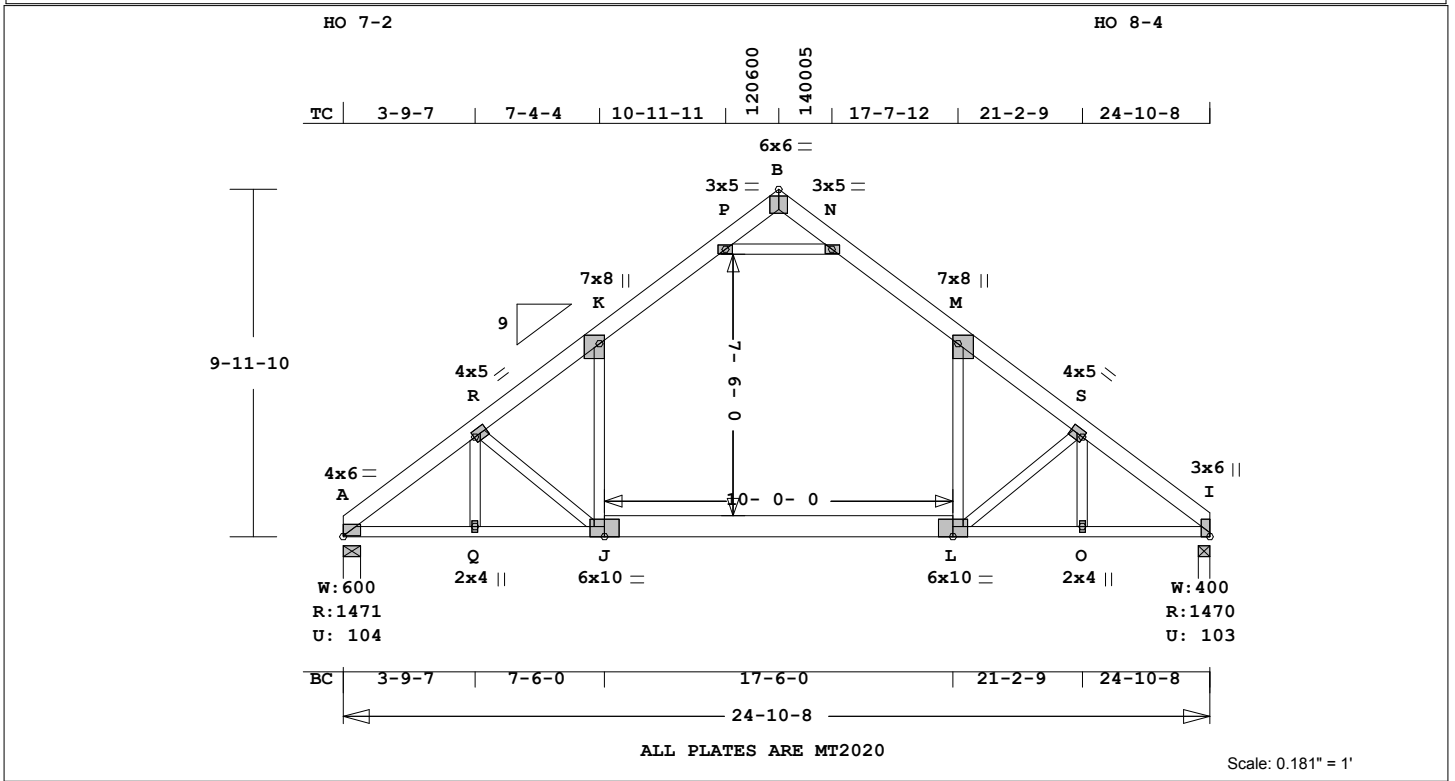

MiTek® Online Plus™ APPROX. TRUSS WEIGHT: 208.8 LBS

Online Plus -- Version 30.0.011
RUN DATE: 18-JUL-12

Southern Pine lumber design values are those effective 06-01-12 by SPIB//ALSC UON
CSI -Size- Lumber-
TC 0.53 2x 6 SP-2400f-2.0E
BC 0.83 2x 4 SP-#2
-- 0.46 2x 8 SP-2400f-2.0E
J -L
WB 0.43 2x 4 SP-#3
ACT 0.74 2x 4 SP-#3

Brace truss as follows:
O.C. From To
TC Cont. 0- 0- 0 24-10- 8
or 48.0" 0- 0- 0 24-10- 8
BC Cont. 0- 0- 0 24-10- 8
or 120.0" 0- 0- 0 24-10- 8
Cont. Attic Chords (Top)
or 36.0" Attic Chords (Top)

psf-Ld Dead Live
TC 7.0 20.0
BC 10.0 0.0
TC+BC 17.0 20.0
Total 37.0 Spacing 24.0"
Lumber Duration Factor 1.25
Plate Duration Factor 1.25
Fb Fc Ft Emin
TC 1.15 1.10 1.10 1.10
BC 1.10 1.10 1.10 1.10

Total Load Reactions (Lbs)
Jt Down Uplift Horiz-
A 1472 105 U 189 R
I 1470 103 U 188 R

Jt Brg Size Required
A 6.0" 1.7"
I 4.0" 1.7"

LC# 1 Attic Loading
Dur Fctrs - Lbr 1.25 Plt 1.25
plf - Dead Live* From To
TC V 14 40 0.0' 24.9'
BC V 20 0 0.0' 24.9'
TC V 10 0 7.5' 10.8'
TC V 10 0 14.2' 17.5'
BC V 10 80 7.5' 17.5'
MA V 10 0 11.0' 14.0'
WB S 10 0 K J
WB S 10 0 M L

Plus 21 Wind Load Case(s)
Plus 2 Unbalanced Load Cases
Plus 1 UBC LL Load Case(s)
Plus 1 DL Load Case(s)
Plus 1 Attic 2 Load Case(s)

Membr	CSI	P Lbs	Axl	CSI-Bnd
-----Top Chords-----				
A -R	0.10	2076	C	0.00 0.10
R -K	0.53	1914	C	0.00 0.53
K -P	0.52	1202	C	0.00 0.52
P -B	0.46	703	T	0.03 0.43
B -N	0.46	701	T	0.03 0.43
N -M	0.51	1205	C	0.00 0.51
M -S	0.52	1906	C	0.00 0.52
S -I	0.12	2050	C	0.00 0.12
-----Bottom Chords-----				
A -Q	0.61	1644	T	0.35 0.26
Q -J	0.80	1646	T	0.29 0.51
J -L	0.46	1337	T	0.04 0.42
L -O	0.83	1614	T	0.29 0.54
O -I	0.64	1612	T	0.34 0.30
-----Webs-----				
Q -R	0.03	106	C	
R -J	0.20	455	C	
J -K	0.43	1070	T	
L -M	0.42	1055	T	
L -S	0.18	419	C	
O -S	0.03	118	C	
-----Attic Chords (Top)-----				
P -N	0.74	2215	C	

TL Defl -0.70" in J -L L/413
LL Defl -0.43" in J -L L/678
Shear // Grain in K -P 0.54

Plates for each ply each face.
Plate - MT20 20 Ga, Gross Area
Plate - MT2H 20 Ga, Gross Area
Plate - MS18 18 Ga, Gross Area
Jt Type Plt Size X Y JSI
A MT20 4.0x 6.0 0.8 0.5 0.65
R MT20 4.0x 5.0 Ctr Ctr 0.32
K MT20 7.0x 8.0-1.8-1.1 0.43
P MT20 3.0x 5.0-0.1 Ctr 0.64
B MT20 6.0x 6.0 Ctr-1.8 0.33
N MT20 3.0x 5.0 0.1 Ctr 0.64
M MT20 7.0x 8.0 1.8-1.1 0.43
S MT20 4.0x 5.0 Ctr Ctr 0.32
I MT20 3.0x 6.0-0.1 0.6 0.86
Q MT20 2.0x 4.0 Ctr Ctr 0.34
J MT20 6.0x10.0 Ctr 1.2 0.53
L MT20 6.0x10.0 Ctr 1.2 0.56
O MT20 2.0x 4.0 Ctr Ctr 0.34

REVIEWED BY:
MiTek Industries, Inc.
6904 Parke East Blvd.
Tampa, FL 33610

REFER TO ONLINE PLUS GENERAL NOTES AND SYMBOLS SHEET FOR ADDITIONAL SPECIFICATIONS.

NOTES:

Trusses Manufactured by:
RIDGWAY ROOF TRUSS
Analysis Conforms To:
FBC2010
TPI 2007
Design checked for 10 psf non-concurrent LL on BC.
Partial-length live loads checked.
Wind Loads - ANSI / ASCE 7-10
Truss is designed as
Components and Claddings* for Exterior zone location.
Wind Speed: 130 mph
Risk Category : II
Mean Roof Height: 25-0
Exposure Category: B
Building Type: Enclosed
TC Dead Load: 4.0 psf
BC Dead Load: 6.0 psf
Max comp. force 2215 Lbs
Max tens. force 1646 Lbs
Connector Plate Fabrication Tolerance = 20%
This truss is designed for a creep factor of 1.5 which is used to calculate total load deflection.

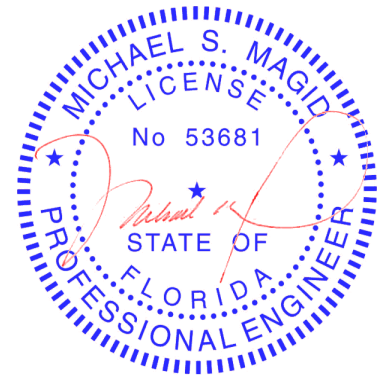

FL Cert. 6634

Job 120440	Mark R4	Quan 1	Type TR	Span 110000	Pl-H1 9	Left OH 0	Right OH 0	Engineering T4462833
----------------------	-------------------	-----------	------------	----------------	------------	--------------	---------------	--------------------------------

18- Rosas- Dreambuilders

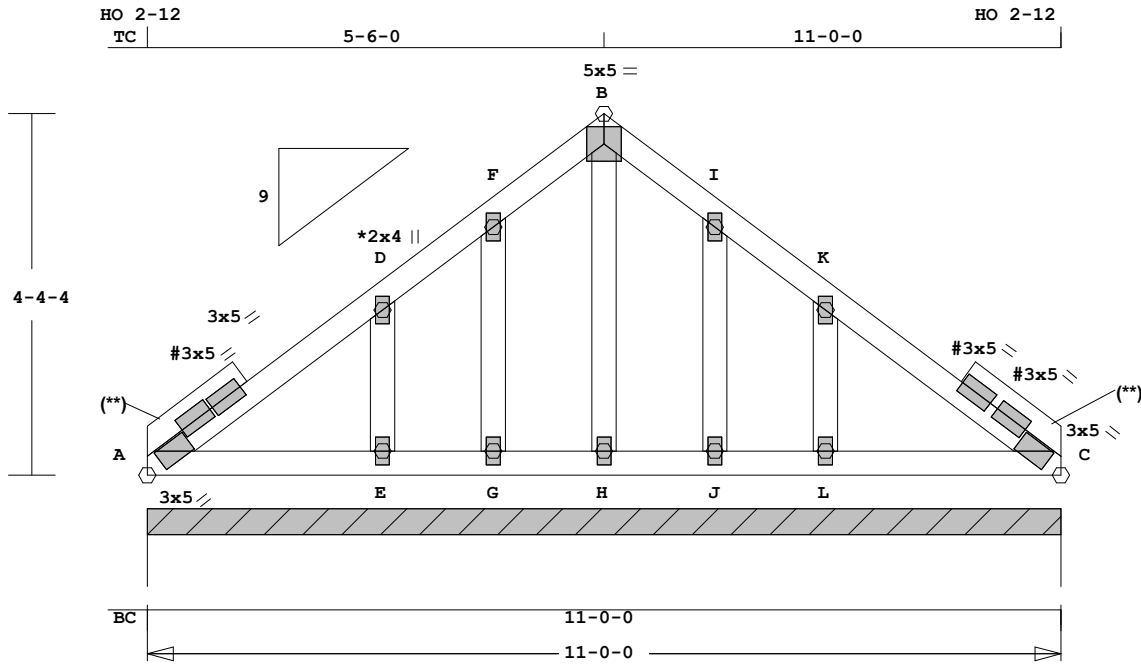

ALL PLATES ARE MT2020, # = PLATE SELECTED IN PLATE MONITOR
See Joint D For Typical Gable Plate Size and Placement

Scale: 0.432" = 1'

Online Plus -- Version 30.0.011
RUN DATE: 18-JUL-12

Southern Pine lumber design values are those effective 06-01-12 by SPIB//ALSC UON
CSI -Size- ---Lumber---
TC 0.05 2x 4 SP-#2 (**)
BC 0.04 2x 4 SP-#2
GW 0.03 2x 4 SP-#3

Brace truss as follows:

	O.C.	From	To
TC Cont.	0- 0- 0	11- 0- 0	0- 0- 0
or	48.0"	0- 0- 0	11- 0- 0
BC Cont.	0- 0- 0	11- 0- 0	0- 0- 0
or	72.0"	0- 0- 0	11- 0- 0

psf-Ild	Dead	Live
TC	7.0	20.0
BC	10.0	0.0
TC+BC	17.0	20.0
Total	37.0	Spacing 24.0"
Lumber Duration Factor	1.25	
Plate Duration Factor	1.25	
	Fb	Fc Ft Emin
TC	1.15	1.10 1.10 1.10
BC	1.10	1.10 1.10 1.10

Total Load Reactions (Lbs)

Jt	Down	Uplift	Horiz-
A	802	192 U	79 R

Jt	Brg Size	Required
A	132.0"	0"-to- 132"

Plus 21 Wind Load Case(s)
Plus 1 UBC LL Load Case(s)
Plus 1 DL Load Case(s)

Membr	CSI	P	Lbs	Axl-CSI-Bnd
-----Top Chords-----				
A -D	0.05	59 C	0.00	0.05
D -F	0.04	57 C	0.00	0.04
F -B	0.01	83 C	0.00	0.01
B -I	0.01	83 C	0.00	0.01
I -K	0.04	57 C	0.00	0.04
K -C	0.05	59 C	0.00	0.05
-----Bottom Chords-----				
A -E	0.04	38 C	0.00	0.04
E -G	0.03	0 T	0.00	0.03
G -H	0.01	0 T	0.00	0.01
H -J	0.01	0 T	0.00	0.01
J -L	0.03	0 T	0.00	0.03

MiTek® Online Plus™ APPROX. TRUSS WEIGHT: 76.4 LBS

L -C	0.04	38 C	0.00	0.04
-----Gable Webs-----				
E -D	0.03	147 C		
G -F	0.01	60 C		
H -B	0.01	42 C		
J -I	0.01	60 C		
L -K	0.03	147 C		
TL Defl	0.00"	in L -C	L/999	
LL Defl	0.00"	in L -C	L/999	
Shear // Grain	in A -D	0.07		

Plates for each ply each face.

Jt Type	Plt Size	X	Y	JSI
A	MT20	3.0x 5.0	Ctr Ctr	0.43
D	MT20	2.0x 4.0	Ctr Ctr	0.00
F	MT20	2.0x 4.0	Ctr Ctr	0.00
B	MT20	5.0x 5.0	Ctr Ctr	0.33
I	MT20	2.0x 4.0	Ctr Ctr	0.00
K	MT20	2.0x 4.0	Ctr Ctr	0.00
C	MT20	3.0x 5.0	Ctr Ctr	0.43
E	MT20	2.0x 4.0	Ctr Ctr	0.00
G	MT20	2.0x 4.0	Ctr Ctr	0.00
H	MT20	2.0x 4.0	Ctr Ctr	0.00
J	MT20	2.0x 4.0	Ctr Ctr	0.00
L	MT20	2.0x 4.0	Ctr Ctr	0.00

REVIEWED BY:
MiTek Industries, Inc.
6904 Parke East Blvd.
Tampa, FL 33610

REFER TO ONLINE PLUS GENERAL NOTES AND SYMBOLS SHEET FOR ADDITIONAL SPECIFICATIONS.

NOTES:
Trusses Manufactured by:
RIDGWAY ROOF TRUSS
Analysis Conforms To:
FBC2010
TPI 2007
Design checked for 10 psf non-concurrent LL on BC.
Truss designed for wind loads in the plane of the truss only. For studs exposed to wind (normal to the face), see Standard Industry Gable End Details as applicable, or consult qualified

Building Designer as per ANSI/TPI 1.
NOTE: USER MODIFIED PLATES This design may have plates selected through a plate monitor.
Wind Loads - ANSI / ASCE 7-10
Truss is designed as Components and Claddings* for Exterior zone location.
Wind Speed: 130 mph
Risk Category : II
Mean Roof Height: 25-0
Exposure Category: B
Building Type: Enclosed
TC Dead Load: 4.0 psf
BC Dead Load: 6.0 psf
Max comp. force 147 Lbs
Max tens. force 117 Lbs
Connector Plate Fabrication
Tolerance = 20%
This truss is designed for a creep factor of 1.5 which is used to calculate total load deflection.

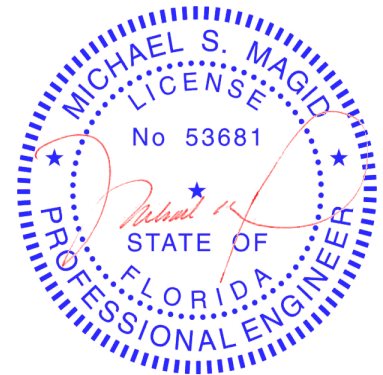

FL Cert. 6634

July 18, 2012

Job 120440	Mark R6	Quan 1	Type MONO	Span 50600	P1-H1 4	Left OH 0	Right OH 0	Engineering T4462835
----------------------	-------------------	-----------	--------------	---------------	------------	--------------	---------------	--------------------------------

18- Rosas- Dreambuilders

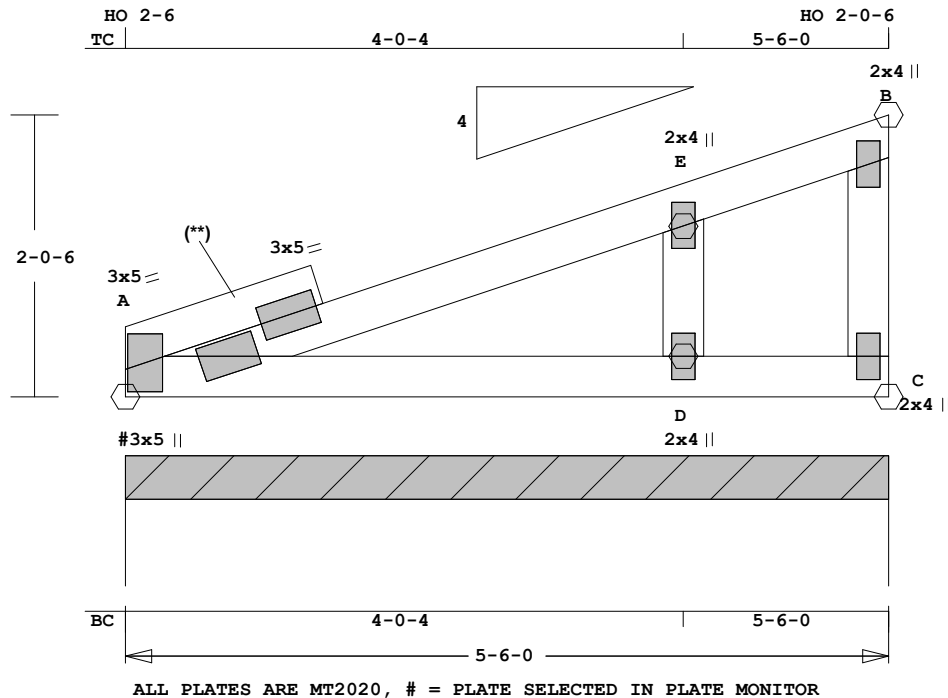

Scale: 0.722" = 1'

Online Plus -- Version 30.0.011
RUN DATE: 18-JUL-12

Southern Pine lumber design values are those effective 06-01-12 by SPIB//ALSC UON
CSI -Size- ---Lumber----
TC 0.11 2x 4 SP-#2 (**)
BC 0.08 2x 4 SP-#2
WB 0.19 2x 4 SP-#3

Brace truss as follows:
O.C. From To
TC Cont. 0- 0- 0 5- 6- 0
or 48.0" 0- 0- 0 5- 6- 0
BC Cont. 0- 0- 0 5- 6- 0
or 66.0" 0- 0- 0 5- 6- 0

psf-Ld Dead Live
TC 7.0 20.0
BC 10.0 0.0
TC+BC 17.0 20.0
Total 37.0 Spacing 24.0"
Lumber Duration Factor 1.25
Plate Duration Factor 1.25
Fb Fc Ft Emin
TC 1.15 1.10 1.10 1.10
BC 1.10 1.10 1.10 1.10

Total Load Reactions (Lbs)
Jt Down Uplift Horiz-
A 386 92 U 56 R

Jt Brg Size Required
A 66.0" 0"-to- 66"

Plus 18 Wind Load Case(s)
Plus 1 UBC LL Load Case(s)
Plus 1 DL Load Case(s)

Membr	CSI	P	Lbs	Ax1	CSI-Bnd
-----Top Chords-----					
A	-E	0.11	79 C	0.00	0.11
E	-B	0.06	33 T	0.00	0.06
-----Bottom Chords-----					
A	-D	0.08	70 C	0.00	0.08
D	-C	0.03	0 T	0.00	0.03

MiTek® Online Plus™ APPROX. TRUSS WEIGHT: 28.2 LBS

-----Webs-----
D -E 0.19 226 T 0.07 0.12
C -B 0.04 57 T 0.00 0.04

TL Defl -0.01" in A -D L/999
LL Defl 0.00" in A -D L/999
Shear // Grain in A -E 0.14

Plates for each ply each face.
Plate - MT20 20 Ga, Gross Area
Plate - MT2H 20 Ga, Gross Area
Plate - MS18 20 Ga, Gross Area
Jt Type Plt Size X Y JSI
A MT20 3.0x 5.0 Ctr Ctr 0.52
E MT20 2.0x 4.0 Ctr Ctr 0.18
B MT20 2.0x 4.0 Ctr Ctr 0.18
D MT20 2.0x 4.0 Ctr Ctr 0.18
C MT20 2.0x 4.0 Ctr Ctr 0.19

REVIEWED BY:
MiTek Industries, Inc.
6904 Parke East Blvd.
Tampa, FL 33610

REFER TO ONLINE PLUS GENERAL NOTES AND SYMBOLS SHEET FOR ADDITIONAL SPECIFICATIONS.

NOTES:
Trusses Manufactured by:
RIDGWAY ROOF TRUSS
Analysis Conforms To:
FBC2010
TPI 2007
Design checked for 10 psf non-concurrent LL on BC.
Truss designed for wind loads in the plane of the truss only. For studs exposed to wind (normal to the face), see Standard Industry Gable End Details as applicable, or consult qualified Building Designer as per ANSI/TPI 1.
NOTE: USER MODIFIED PLATES
This design may have plates

selected through a plate monitor.
Wind Loads - ANSI / ASCE 7-10
Truss is designed as Components and Claddings* for Exterior zone location.
Wind Speed: 130 mph
Risk Category : II
Mean Roof Height: 25-0
Exposure Category: B
Building Type: Enclosed
TC Dead Load: 4.0 psf
BC Dead Load: 6.0 psf
Max comp. force 144 Lbs
Max tens. force 226 Lbs
Connector Plate Fabrication Tolerance = 20%
This truss is designed for a creep factor of 1.5 which is used to calculate total load deflection.

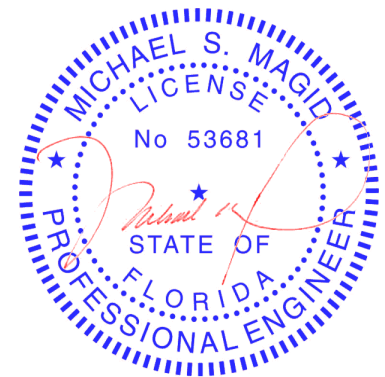

FL Cert. 6634

Job 120440	Mark R7	Quan 14	Type MONO	Span 50600	P1-H1 4	Left OH 0	Right OH 0	Engineering T4462836
----------------------	-------------------	------------	--------------	---------------	------------	--------------	---------------	--------------------------------

18- Rosas- Dreambuilders

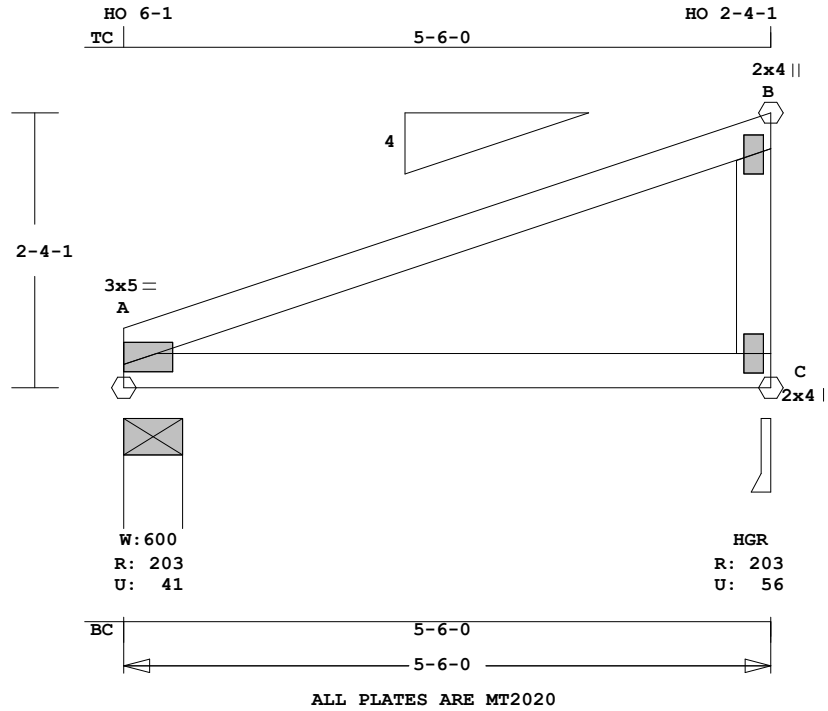

Scale: 0.612" = 1'

MiTek® Online Plus™ APPROX. TRUSS WEIGHT: 24.8 LBS

Online Plus -- Version 30.0.011
RUN DATE: 18-JUL-12

Southern Pine lumber design values are those effective 06-01-12 by SPIB//ALSC UON
CSI -Size- ---Lumber----

TC	0.42	2x 4	SP-#2
BC	0.27	2x 4	SP-#2
WB	0.09	2x 4	SP-#3

Brace truss as follows:

	O.C.	From	To
TC Cont.	0- 0- 0	5- 6- 0	or 48.0"
BC Cont.	0- 0- 0	5- 6- 0	or 66.0"

psf-Ld	Dead	Live		
TC	7.0	20.0		
BC	10.0	0.0		
TC+BC	17.0	20.0		
Total	37.0	Spacing 24.0"		
Lumber	Duration Factor	1.25		
Plate	Duration Factor	1.25		
	Fb	Fc	Ft	Emin
TC	1.15	1.10	1.10	1.10
BC	1.10	1.10	1.10	1.10

Total Load Reactions (Lbs)

Jt	Down	Uplift	Horiz
A	204	41 U	27 R
C	203	56 U	64 R

Jt	Brg Size	Required
A	6.0"	1.5"
C	3.5"	1.5"

Plus 18 Wind Load Case(s)
Plus 1 UBC LL Load Case(s)
Plus 1 DL Load Case(s)

Membr	CSI	P	Lbs	Ax1-CSI-Bnd
-----Top Chords-----				
A -B	0.42	99 C	0.00	0.42
-----Bottom Chords-----				
A -C	0.27	49 T	0.00	0.27

-----Webs-----
C -B 0.09 227 T WindLd

TL Defl -0.07" in A -C L/781
LL Defl -0.03" in A -C L/999
Shear // Grain in A -B 0.19

Plates for each ply each face.
Plate - MT20 20 Ga, Gross Area
Plate - MT2H 20 Ga, Gross Area
Plate - MS18 18 Ga, Gross Area
Jt Type Plt Size X Y JSI
A MT20 3.0x 5.0 0.8 0.2 0.61
B MT20 2.0x 4.0 Ctr Ctr 0.19
C MT20 2.0x 4.0 Ctr Ctr 0.20

REVIEWED BY:
MiTek Industries, Inc.
6904 Parke East Blvd.
Tampa, FL 33610

REFER TO ONLINE PLUS GENERAL NOTES AND SYMBOLS SHEET FOR ADDITIONAL SPECIFICATIONS.

NOTES:
Trusses Manufactured by:
RIDGWAY ROOF TRUSS
Analysis Conforms To:
FBC2010
TPI 2007

This truss has been designed for 20.0 psf LL on the B.C. in areas where a rectangle 3- 6- 0 tall by 2- 0- 0 wide will fit between the B.C. and any other member.

Design checked for 10 psf non-concurrent LL on BC.

Wind Loads - ANSI / ASCE 7-10

Truss is designed as Components and Claddings* for Exterior zone location.
Wind Speed: 130 mph
Risk Category : II
Mean Roof Height: 25-0

Exposure Category: B
Building Type: Enclosed
TC Dead Load: 4.0 psf
BC Dead Load: 6.0 psf
Max comp. force 136 Lbs
Max tens. force 227 Lbs
Connector Plate Fabrication Tolerance = 20%
This truss is designed for a creep factor of 1.5 which is used to calculate total load deflection.

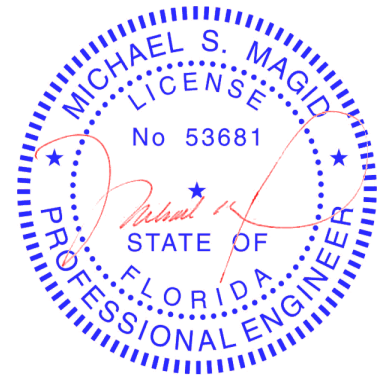

FL Cert. 6634

Job 120440	Mark R8	Quan 2	Type MONO	Span 70600	Pl-H1 4	Left OH 0	Right OH 0	Engineering T4462837
----------------------	-------------------	-----------	--------------	---------------	------------	--------------	---------------	--------------------------------

18- Rosas- Dreambuilders

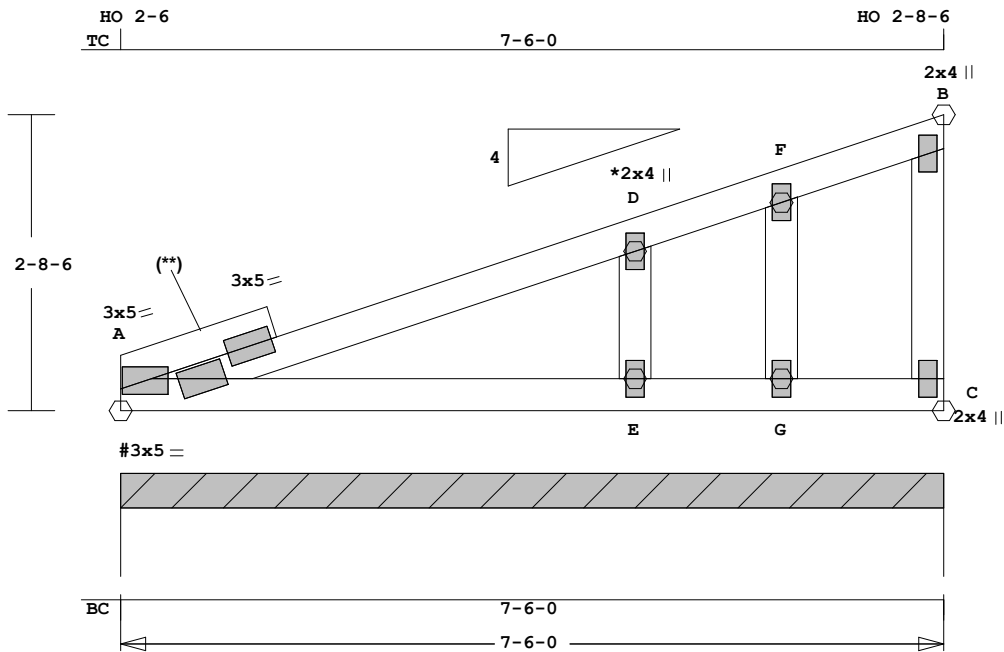

ALL PLATES ARE MT2020, # = PLATE SELECTED IN PLATE MONITOR
See Joint D For Typical Gable Plate Size and Placement

Scale: 0.571" = 1'

Online Plus -- Version 30.0.011
RUN DATE: 18-JUL-12

Southern Pine lumber design values are those effective 06-01-12 by SPIB//ALSC UON
CSI -Size- ---Lumber----

TC	0.16	2x 4	SP-#2 (**)
BC	0.12	2x 4	SP-#2
WB	0.08	2x 4	SP-#3
GW	0.21	2x 4	SP-#3

Brace truss as follows:

	O.C.	From	To
TC Cont.	0- 0- 0	7- 6- 0	
or	48.0"	0- 0- 0	7- 6- 0
BC Cont.	0- 0- 0	7- 6- 0	
or	72.0"	0- 0- 0	7- 6- 0

psf-Ld	Dead	Live		
TC	7.0	20.0		
BC	10.0	0.0		
TC+BC	17.0	20.0		
Total	37.0	Spacing 24.0"		
Lumber	Duration Factor	1.25		
Plate	Duration Factor	1.25		
	Fb	Fc	Ft	Emin
TC	1.15	1.10	1.10	1.10
BC	1.10	1.10	1.10	1.10

Total Load Reactions (Lbs)

Jt	Down	Uplift	Horiz-
A	534	128 U	80 R

Jt	Brg Size	Required
A	90.0"	0"-to- 90"

Plus 18 Wind Load Case(s)
Plus 1 UBC LL Load Case(s)
Plus 1 DL Load Case(s)

Membr	CSI	P	Lbs	Axl	CSI-Bnd
-----Top Chords-----					
A	-D	0.16	118 C	0.00	0.16
D	-F	0.08	78 C	0.00	0.08
F	-B	0.02	47 T	0.00	0.02
-----Bottom Chords-----					
A	-E	0.12	96 C	0.00	0.12
E	-G	0.05	0 T	0.00	0.05

MiTek® Online Plus™ APPROX. TRUSS WEIGHT: 40.7 LBS

	G	-C	0.03	0 T	0.00	0.03
-----Webs-----						
C	-B	0.08	72 T	0.01	0.07	
-----Gable Webs-----						
E	-D	0.21	176 T	0.00	0.21	
G	-F	0.05	107 T	0.03	0.02	

TL Defl -0.02" in A -E L/999
LL Defl -0.01" in A -E L/999
Shear // Grain in A -D 0.15

Plates for each ply each face.
Plate - MT20 20 Ga, Gross Area
Plate - MT2H 20 Ga, Gross Area
Plate - MS18 20 Ga, Gross Area
Jt Type Plt Size X Y JSI
A MT20 3.0x 5.0 Ctr Ctr 0.52
D MT20 2.0x 4.0 Ctr Ctr 0.00
F MT20 2.0x 4.0 Ctr Ctr 0.00
B MT20 2.0x 4.0 Ctr Ctr 0.33
E MT20 2.0x 4.0 Ctr Ctr 0.00
G MT20 2.0x 4.0 Ctr Ctr 0.00
C MT20 2.0x 4.0 Ctr Ctr 0.39

REVIEWED BY:
MiTek Industries, Inc.
6904 Parke East Blvd.
Tampa, FL 33610

REFER TO ONLINE PLUS GENERAL NOTES AND SYMBOLS SHEET FOR ADDITIONAL SPECIFICATIONS.

NOTES:
Trusses Manufactured by:
RIDGWAY ROOF TRUSS
Analysis Conforms To:
FBC2010
TPI 2007

Design checked for 10 psf non-concurrent LL on BC.

Truss designed for wind loads in the plane of the truss only. For studs exposed to wind (normal to the face), see Standard Industry Gable End Details as applicable, or consult qualified Building Designer as per

ANSI/TPI 1.
NOTE: USER MODIFIED PLATES
This design may have plates selected through a plate monitor.

Wind Loads - ANSI / ASCE 7-10
Truss is designed as

Components and Claddings* for Exterior zone location.
Wind Speed: 130 mph
Risk Category: II
Mean Roof Height: 25-0
Exposure Category: B
Building Type: Enclosed
TC Dead Load: 4.0 psf
BC Dead Load: 6.0 psf
Max comp. force 169 Lbs
Max tens. force 176 Lbs
Connector Plate Fabrication Tolerance = 20%

This truss is designed for a creep factor of 1.5 which is used to calculate total load deflection.

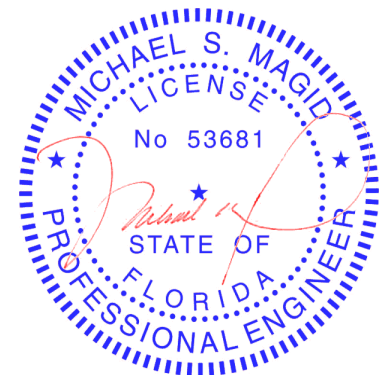

FL Cert. 6634

July 18, 2012

Job 120440	Mark R9	Quan 2	Type MONO	Span 80000	P1-H1 4	Left OH 0	Right OH 0	Engineering T4462838
----------------------	-------------------	-----------	--------------	---------------	------------	--------------	---------------	--------------------------------

18- Rosas- Dreambuilders

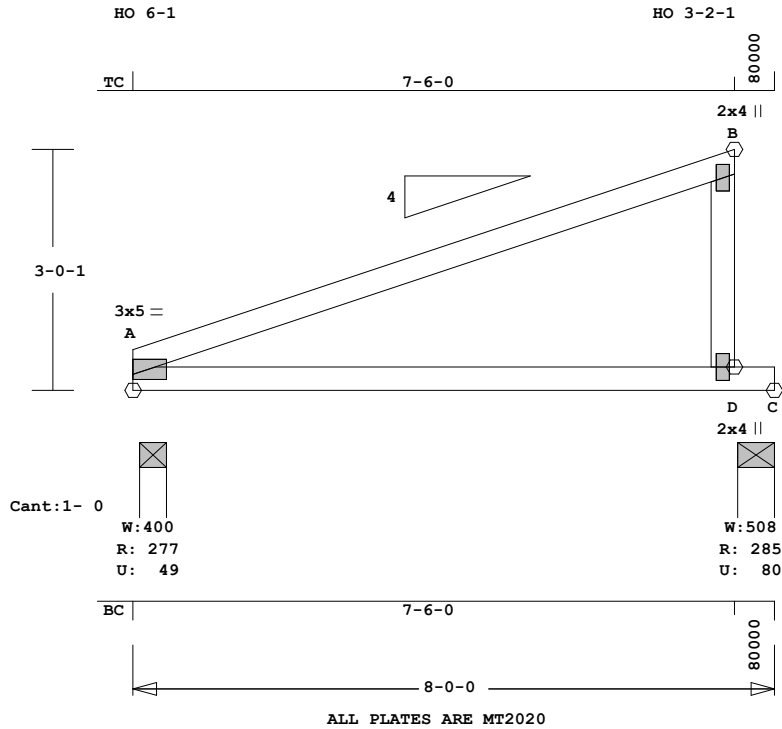

Scale: 0.418" = 1'

Online Plus -- Version 30.0.011
RUN DATE: 18-JUL-12

Southern Pine lumber design values are those effective
06-01-12 by SPIB//ALSC UON
CSI -Size- ---Lumber----
TC 0.46 2x 4 SP-#1
BC 0.49 2x 4 SP-#2
WB 0.07 2x 4 SP-#3

Brace truss as follows:
O.C. From To
TC Cont. 0- 0- 0 8- 0- 0
or 48.0" 0- 0- 0 8- 0- 0
BC Cont. 0- 0- 0 8- 0- 0
or 90.0" 0- 0- 0 8- 0- 0

psf-Ld	Dead	Live	Spacing	
TC	7.0	20.0	24.0"	
BC	10.0	0.0		
TC+BC	17.0	20.0		
Total	37.0		24.0"	
Lumber	Duration Factor	1.25		
Plate	Duration Factor	1.25		
	Fb	Fc	Ft	Emin
TC	1.15	1.10	1.10	1.10
BC	1.10	1.10	1.10	1.10

Total Load Reactions (Lbs)

Jt	Down	Uplift	Horiz
A	277	49 U	94 R
D	285	81 U	51 R

Jt	Brg Size	Required
A	4.0"	1.5"
D	5.5"	5.5"

Plus 18 Wind Load Case(s)
Plus 1 UBC LL Load Case(s)
Plus 1 DL Load Case(s)

Membr	CSI	P	Lbs	Axl	CSI-Bnd
-----Top Chords-----					
A -B	0.46		88 C	0.00	0.46
-----Bottom Chords-----					
A -D	0.49		50 T	0.00	0.49

MiTek® Online Plus™ APPROX. TRUSS WEIGHT: 34.8 LBS

D -C 0.00 0 T
-----Webs-----
D -B 0.07 249 T WindLd

TL Defl -0.25" in A -D L/342
LL Defl -0.11" in A -D L/783
Shear // Grain in A -B 0.25

Plates for each ply each face.
Plate - MT20 20 Ga, Gross Area
Plate - MT2H 20 Ga, Gross Area
Plate - MS18 18 Ga, Gross Area
Jt Type Plt Size X Y JSI
A MT20 3.0x 5.0 0.8 0.2 0.61
B MT20 2.0x 4.0 Ctr Ctr 0.21
D MT20 2.0x 4.0 Ctr Ctr 0.22

REVIEWED BY:
MiTek Industries, Inc.
6904 Parke East Blvd.
Tampa, FL 33610

REFER TO ONLINE PLUS GENERAL
NOTES AND SYMBOLS SHEET FOR
ADDITIONAL SPECIFICATIONS.

NOTES:
Trusses Manufactured by:
RIDGWAY ROOF TRUSS
Analysis Conforms To:

FBC2010
TPI 2007
This truss has been designed
for 20.0 psf LL on the B.C.
in areas where a rectangle
3- 6- 0 tall by
2- 0- 0 wide
will fit between the B.C.
and any other member.
Design checked for 10 psf non-
concurrent LL on BC.

Wind Loads - ANSI / ASCE 7-10
Truss is designed as
Components and Claddings*
for Exterior zone location.
Wind Speed: 130 mph
Risk Category : II

Mean Roof Height: 25-0
Exposure Category: B
Building Type: Enclosed
TC Dead Load: 4.0 psf
BC Dead Load: 6.0 psf
Max comp. force 189 Lbs
Max tens. force 249 Lbs
Connector Plate Fabrication
Tolerance = 20%
This truss is designed for a
creep factor of 1.5 which
is used to calculate total
load deflection.

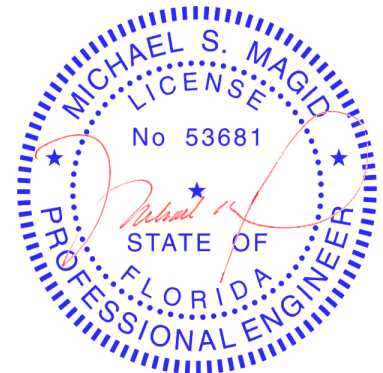

FL Cert. 6634

Job 120440	Mark R12	Quan 1	Type HHIP	Span 160600	Pl-H1 4	Left OH 0	Right OH 0	Engineering T4462839
----------------------	--------------------	-----------	--------------	----------------	------------	--------------	---------------	--------------------------------

18- Rosas- Dreambuilders

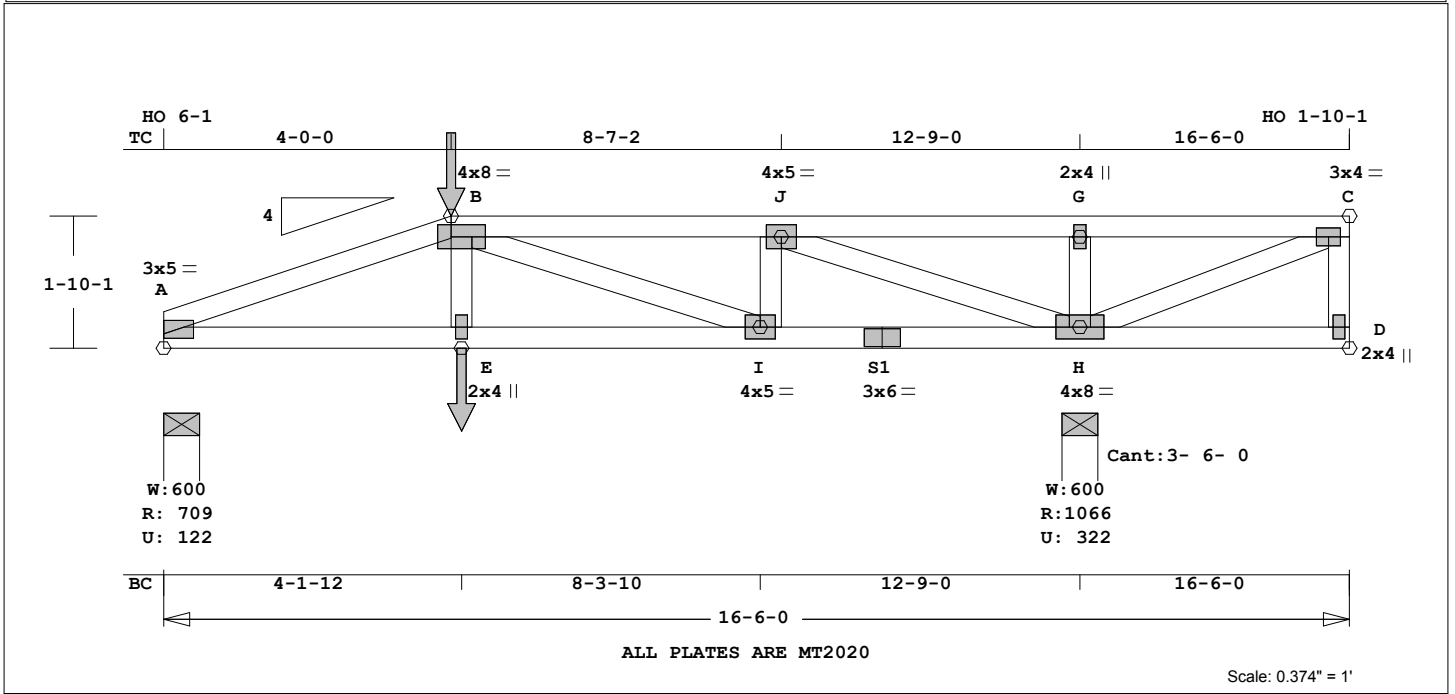

MiTek® Online Plus™ APPROX. TRUSS WEIGHT: 95.0 LBS

Online Plus -- Version 30.0.011
RUN DATE: 18-JUL-12

Southern Pine lumber design values are those effective 06-01-12 by SPIB//ALSC UON
CSI -Size- ---Lumber---
TC 0.42 2x 4 SP-#2
BC 0.71 2x 4 SP-#2
WB 0.74 2x 4 SP-#3

Brace truss as follows:
O.C. From To
TC Cont. 0- 0- 0 16- 6- 0
or 48.0" 0- 0- 0 16- 6- 0
BC Cont. 0- 0- 0 16- 6- 0
or 102.0" 0- 0- 0 16- 6- 0

psf-Ld Dead Live
TC 7.0 20.0
BC 10.0 0.0
TC+BC 17.0 20.0
Total 37.0 Spacing 24.0"
Lumber Duration Factor 1.25
Plate Duration Factor 1.25
Fb Fc Ft Emin
TC 1.00 1.00 1.00 1.00
BC 1.00 1.00 1.00 1.00

Total Load Reactions (lbs)
Jt Down Uplift Horiz-
A 710 122 U 19 R
H 1067 323 U 49 R

Jt Brg Size Required
A 6.0" 1.5"
H 6.0" 1.5"

LC# 1 Standard Loading
Dur Fctrs - Lbr 1.25 Plt 1.25
plf - Dead Live* From To
TC V 14 40 0.0' 16.5'
BC V 20 0 0.0' 16.5'
TC V 7 20 4.0' 12.8'
BC V 10 0 4.0' 12.8'
TC V 92 62 4.0' CL-LB
BC V 47 31 4.1' CL-LB

Plus 21 Wind Load Case(s)
Plus 1 UBC LL Load Case(s)
Plus 1 DL Load Case(s)

Membr CSI P Lbs Ax1-CSI-Bnd
-----Top Chords-----
A -B 0.42 1484 C 0.04 0.38

B -J	0.36	1299	C	0.03	0.33
J -G	0.34	230	C	0.05	0.29
G -C	0.34	230	C	0.05	0.29
-----Bottom Chords-----					
A -E	0.71	1398	T	0.32	0.39
E -I	0.54	1387	T	0.32	0.22
I -S1	0.39	1299	T	0.30	0.09
S1-H	0.44	1299	T	0.30	0.14
H -D	0.16	29	T	0.00	0.16
-----Webs-----					
E -B	0.07	207	T		
B -I	0.06	155	C		
I -J	0.09	280	T		
J -H	0.74	1609	C		
H -G	0.07	307	C		
H -C	0.08	277	T		
D -C	0.01	65	C		WindLd

TL Defl -0.16" in E -I L/882
LL Defl -0.06" in E -I L/999
LL Cant 0.02" in H -D L/999
Shear // Grain in B -J 0.25

Plates for each ply each face.
Plate - MT20 20 Ga, Gross Area
Plate - MT2H 20 Ga, Gross Area
Plate - MS18 18 Ga, Gross Area
Jt Type Plt Size X Y JSI
A MT20 3.0x 5.0 0.8 0.2 0.61
B MT20 4.0x 8.0 Ctr Ctr 0.58
J MT20 4.0x 5.0 Ctr Ctr 0.67
G MT20 2.0x 4.0 Ctr Ctr 0.34
C MT20 3.0x 4.0 Ctr Ctr 0.34
E MT20 2.0x 4.0 Ctr Ctr 0.34
I MT20 4.0x 5.0 Ctr Ctr 0.25
S1 MT20 3.0x 6.0 Ctr Ctr 0.51
H MT20 4.0x 8.0 Ctr Ctr 0.75
D MT20 2.0x 4.0 Ctr Ctr 0.33

REVIEWED BY:
MiTek Industries, Inc.
6904 Parke East Blvd.
Tampa, FL 33610

REFER TO ONLINE PLUS GENERAL NOTES AND SYMBOLS SHEET FOR ADDITIONAL SPECIFICATIONS.

NOTES:
Trusses Manufactured by:
RIDGWAY ROOF TRUSS
Analysis Conforms To:
FBC2010
TPI 2007
This truss has been designed

for 20.0 psf LL on the B.C. in areas where a rectangle 3- 6- 0 tall by 2- 0- 0 wide will fit between the B.C. and any other member.
Design checked for 10 psf non-concurrent LL on BC.
Wind Loads - ANSI / ASCE 7-10
Truss is designed as Components and Claddings* for Exterior zone location.
Wind Speed: 130 mph
Risk Category : II
Mean Roof Height: 25-0
Exposure Category: B
Building Type: Enclosed
TC Dead Load: 4.0 psf
BC Dead Load: 6.0 psf
Max comp. force 1609 Lbs
Max tens. force 1398 Lbs
Connector Plate Fabrication Tolerance = 20%
This truss is designed for a creep factor of 1.5 which is used to calculate total load deflection.

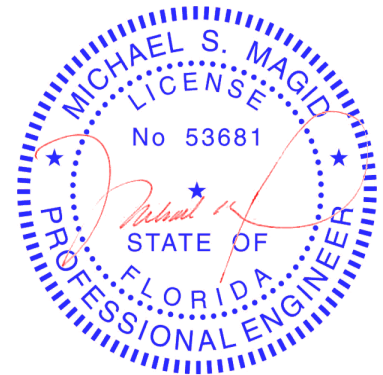

FL Cert. 6634

Job 120440	Mark R13	Quan 5	Type MONO	Span 40000	Pl-H1 4	Left OH 0	Right OH 0	Engineering T4462840
----------------------	--------------------	-----------	--------------	---------------	------------	--------------	---------------	--------------------------------

18- Rosas- Dreambuilders

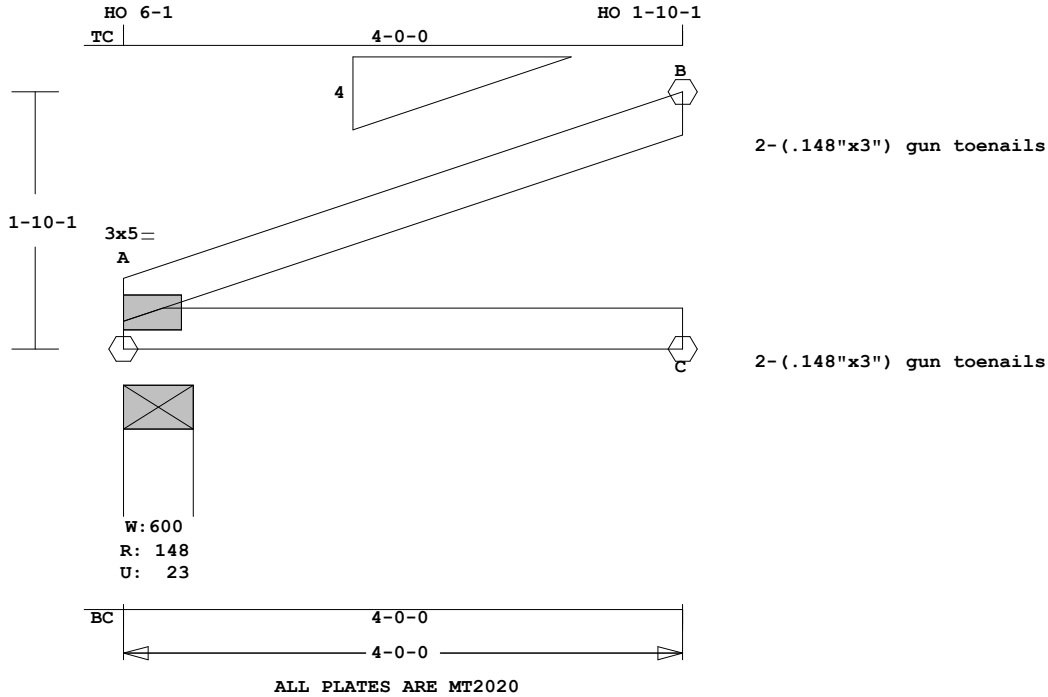

Scale: 0.728" = 1'

MiTek® Online Plus™ APPROX. TRUSS WEIGHT: 15.7 LBS

Online Plus -- Version 30.0.011
RUN DATE: 18-JUL-12

Southern Pine lumber design values are those effective 06-01-12 by SPIB//ALSC UON
CSI -Size- ----Lumber-----
TC 0.23 2x 4 SP-#2
BC 0.16 2x 4 SP-#2

Brace truss as follows:
O.C. From To
TC Cont. 0- 0- 0 4- 0- 0
or 48.0" 0- 0- 0 4- 0- 0
BC Cont. 0- 0- 0 4- 0- 0
or 48.0" 0- 0- 0 4- 0- 0

psf-Ld	Dead	Live		
TC	7.0	20.0		
BC	10.0	0.0		
TC+BC	17.0	20.0		
Total	37.0	Spacing 24.0"		
Lumber	Duration Factor	1.25		
Plate	Duration Factor	1.25		
	Fb	Fc	Ft	Emin
TC	1.15	1.10	1.10	1.10
BC	1.10	1.10	1.10	1.10

Total Load Reactions (Lbs)
Jt Down Uplift Horiz-
A 149 24 U 50 R
C 75
B 99 59 U 27 R

Jt	Brg Size	Required
A	6.0"	1.5"
C	3.5"	1.5"
B	1.5"	1.5"

Plus 18 Wind Load Case(s)
Plus 1 UBC LL Load Case(s)
Plus 1 DL Load Case(s)

Membr	CSI	P	Lbs	Ax1	CSI-Bnd
-----Top Chords-----					
A -B	0.23	58	C	0.00	0.23
-----Bottom Chords-----					

A -C 0.16 0 T 0.00 0.16

TL Defl -0.02" in A -C L/999
LL Defl -0.01" in A -C L/999
Shear // Grain in A -B 0.15

Plates for each ply each face.
Plate - MT20 20 Ga, Gross Area
Plate - MT2H 20 Ga, Gross Area
Plate - MS18 18 Ga, Gross Area
Jt Type Plt Size X Y JSI
A MT20 3.0x 5.0 0.8 0.2 0.61

REVIEWED BY:
MiTek Industries, Inc.
6904 Parke East Blvd.
Tampa, FL 33610

REFER TO ONLINE PLUS GENERAL NOTES AND SYMBOLS SHEET FOR ADDITIONAL SPECIFICATIONS.

For proper installation of toe-nails, refer to the 2005 National Design Specification (NDS) for Wood Construction

NOTES:

Trusses Manufactured by:
RIDGWAY ROOF TRUSS

Analysis Conforms To:
FBC2010
TPI 2007

This truss has been designed for 20.0 psf LL on the B.C. in areas where a rectangle 3- 6- 0 tall by 2- 0- 0 wide will fit between the B.C. and any other member.

Design checked for 10 psf non-concurrent LL on BC.
Wind Loads - ANSI / ASCE 7-10
Truss is designed as Components and Claddings* for Exterior zone location.
Wind Speed: 130 mph

Risk Category : II
Mean Roof Height: 25-0
Exposure Category: B
Building Type: Enclosed
TC Dead Load: 4.0 psf
BC Dead Load: 6.0 psf
Max comp. force 58 Lbs
Max tens. force 16 Lbs
Connector Plate Fabrication Tolerance = 20%

This truss is designed for a creep factor of 1.5 which is used to calculate total load deflection.

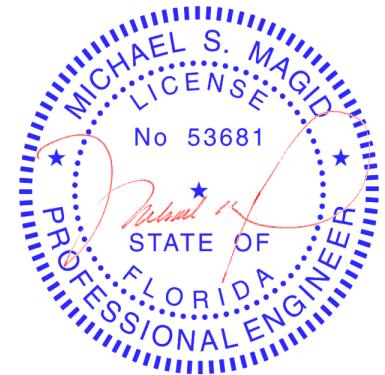

FL Cert. 6634

Job 120440	Mark R14	Quan 2	Type JACK1	Span 1111	Pl-H1 4	Left OH 0	Right OH 0	Engineering T4462841
----------------------	--------------------	-----------	---------------	--------------	------------	--------------	---------------	--------------------------------

18- Rosas- Dreambuilders

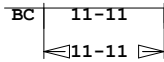
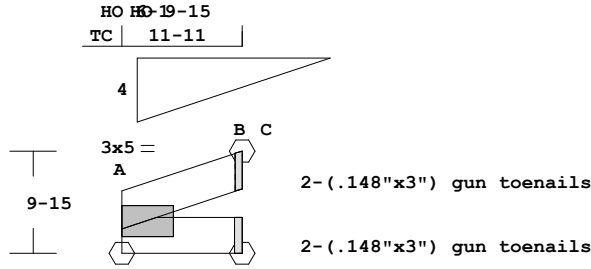

ALL PLATES ARE MT2020

Scale: 0.643" = 1'

MiTek® Online Plus™ APPROX. TRUSS WEIGHT: 4.0 LBS

Online Plus -- Version 30.0.011
RUN DATE: 18-JUL-12

Southern Pine lumber design values are those effective 06-01-12 by SPIB//ALSC UON
CSI -Size- ----Lumber----
TC 0.01 2x 4 SP-#2
BC 0.00 2x 4 SP-#2

Brace truss as follows:

O.C.	From	To
TC Cont.	0- 0- 0	0-11-11
or 11.7"	0- 0- 0	0-11-11
BC Cont.	0- 0- 0	0-11-11
or 11.7"	0- 0- 0	0-11-11

psf-Ld	Dead	Live		
TC	7.0	20.0		
BC	10.0	0.0		
TC+BC	17.0	20.0		
Total	37.0	Spacing 24.0"		
Lumber	Duration Factor	1.25		
Plate	Duration Factor	1.25		
	Fb	Fc	Ft	Emin
TC	1.15	1.10	1.10	1.10
BC	1.10	1.10	1.10	1.10

Total Load Reactions (Lbs)

Jt	Down	Uplift	Horiz-
A	40	4 U	12 R
B	22	15 U	
C	17		7 R

Jt	Brg Size	Required
A	3.5"	1.5"
B	1.5"	1.5"
C	1.5"	1.5"

Plus 18 Wind Load Case(s)
Plus 1 UBC LL Load Case(s)
Plus 1 DL Load Case(s)

Membr	CSI	P	Lbs	Ax1	CSI-Bnd
-----Top Chords-----					
A -B	0.01		14 C	0.00	0.01
-----Bottom Chords-----					

A -C 0.00 6 T

TL Defl 0.00" in A -C L/999
LL Defl 0.00" in A -C L/999
Shear // Grain in A -B 0.03

Plates for each ply each face.
Plate - MT20 20 Ga, Gross Area
Plate - MT2H 20 Ga, Gross Area
Plate - MS18 18 Ga, Gross Area
Jt Type Plt Size X Y JSI
A MT20 3.0x 5.0 0.8 0.2 0.61

REVIEWED BY:
MiTek Industries, Inc.
6904 Parke East Blvd.
Tampa, FL 33610

REFER TO ONLINE PLUS GENERAL NOTES AND SYMBOLS SHEET FOR ADDITIONAL SPECIFICATIONS.

For proper installation of toe-nails, refer to the 2005 National Design Specification (NDS) for Wood Construction

NOTES:

Trusses Manufactured by:
RIDGWAY ROOF TRUSS

Analysis Conforms To:
FBC2010
TPI 2007

This truss has been designed for 20.0 psf LL on the B.C. in areas where a rectangle 3- 6- 0 tall by 2- 0- 0 wide will fit between the B.C. and any other member.

Design checked for 10 psf non-concurrent LL on BC.
Wind Loads - ANSI / ASCE 7-10
Truss is designed as Components and Claddings* for Exterior zone location.
Wind Speed: 130 mph

Risk Category : II
Mean Roof Height: 25-0
Exposure Category: B
Building Type: Enclosed
TC Dead Load: 4.0 psf
BC Dead Load: 6.0 psf
Max comp. force 14 Lbs
Max tens. force 6 Lbs
Connector Plate Fabrication Tolerance = 20%
This truss is designed for a creep factor of 1.5 which is used to calculate total load deflection.

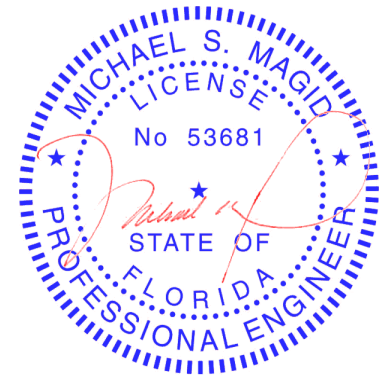

FL Cert. 6634

Job 120440	Mark R15	Quan 3	Type JACK1	Span 21111	Pl-H1 4	Left OH 0	Right OH 0	Engineering T4462842
----------------------	--------------------	-----------	---------------	---------------	------------	--------------	---------------	--------------------------------

18- Rosas- Dreambuilders

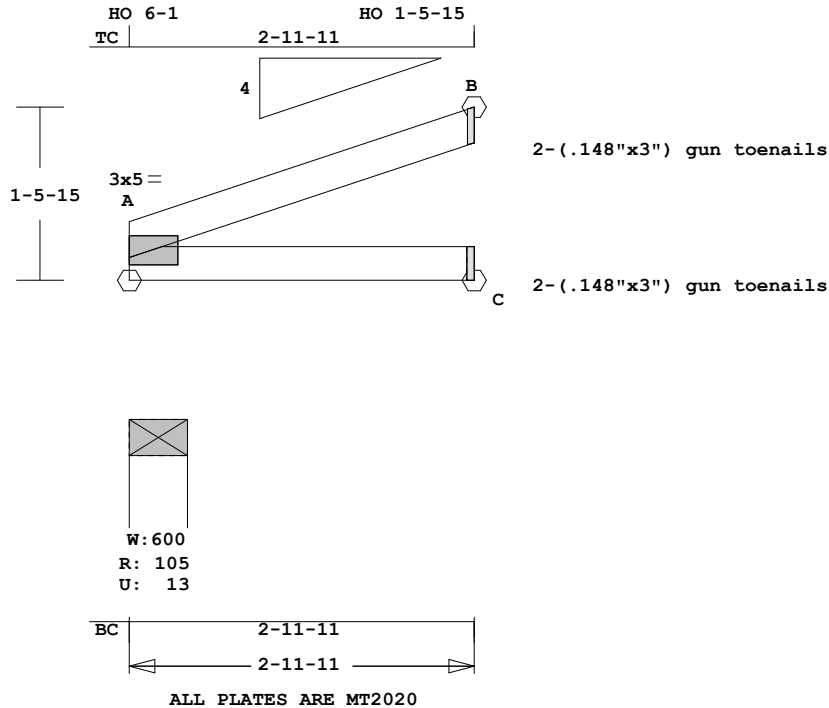

Scale: 0.604" = 1'

MiTek® Online Plus™ APPROX. TRUSS WEIGHT: 11.7 LBS

Online Plus -- Version 30.0.011
RUN DATE: 18-JUL-12

Southern Pine lumber design values are those effective 06-01-12 by SPIB//ALSC UON

CSI -Size- ----Lumber-----
TC 0.10 2x 4 SP-#2
BC 0.08 2x 4 SP-#2

Brace truss as follows:
O.C. From To
TC Cont. 0- 0- 0 2-11-11
or 35.7" 0- 0- 0 2-11-11
BC Cont. 0- 0- 0 2-11-11
or 35.7" 0- 0- 0 2-11-11

psf-Ld	Dead	Live		
TC	7.0	20.0		
BC	10.0	0.0		
TC+BC	17.0	20.0		
Total	37.0	Spacing 24.0"		
Lumber	Duration Factor	1.25		
Plate	Duration Factor	1.25		
	Fb	Fc	Ft	Emin
TC	1.15	1.10	1.10	1.10
BC	1.10	1.10	1.10	1.10

Total Load Reactions (Lbs)
Jt Down Uplift Horiz-
A 106 14 U 37 R
C 55
B 80 48 U 20 R

Jt	Brg Size	Required
A	6.0"	1.5"
C	3.5"	1.5"
B	3.5"	1.5"

Plus 18 Wind Load Case(s)
Plus 1 UBC LL Load Case(s)
Plus 1 DL Load Case(s)

Membr	CSI	P	Lbs	Ax1	CSI-Bnd
-----Top Chords-----					
A	-B	0.10	48	C	0.00 0.10
-----Bottom Chords-----					

A -C 0.08 0 T 0.00 0.08

TL Defl 0.00" in A -C L/999
LL Defl 0.00" in A -C L/999
Shear // Grain in A -B 0.12

Plates for each ply each face.
Plate - MT20 20 Ga, Gross Area
Plate - MT2H 20 Ga, Gross Area
Plate - MS18 18 Ga, Gross Area
Jt Type Plt Size X Y JSI
A MT20 3.0x 5.0 0.8 0.2 0.61

REVIEWED BY:
MiTek Industries, Inc.
6904 Parke East Blvd.
Tampa, FL 33610

REFER TO ONLINE PLUS GENERAL NOTES AND SYMBOLS SHEET FOR ADDITIONAL SPECIFICATIONS.

For proper installation of toe-nails, refer to the 2005 National Design Specification (NDS) for Wood Construction

NOTES:

Trusses Manufactured by:
RIDGWAY ROOF TRUSS

Analysis Conforms To:
FBC2010
TPI 2007

This truss has been designed for 20.0 psf LL on the B.C. in areas where a rectangle 3- 6- 0 tall by 2- 0- 0 wide will fit between the B.C. and any other member.

Design checked for 10 psf non-concurrent LL on BC.
Wind Loads - ANSI / ASCE 7-10
Truss is designed as Components and Claddings* for Exterior zone location.
Wind Speed: 130 mph

Risk Category : II
Mean Roof Height: 25-0
Exposure Category: B
Building Type: Enclosed
TC Dead Load: 4.0 psf
BC Dead Load: 6.0 psf
Max comp. force 48 Lbs
Max tens. force 11 Lbs
Connector Plate Fabrication Tolerance = 20%

This truss is designed for a creep factor of 1.5 which is used to calculate total load deflection.

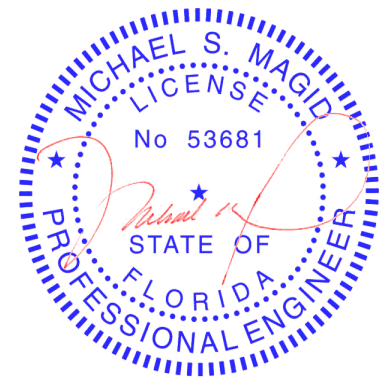

FL Cert. 6634

Job 120440	Mark R16	Quan 1	Type KING	Span 50702	P1-H1 2.828	Left OH 0	Right OH 0	Engineering T4462843
----------------------	--------------------	-----------	--------------	---------------	----------------	--------------	---------------	--------------------------------

18- Rosas- Dreambuilders

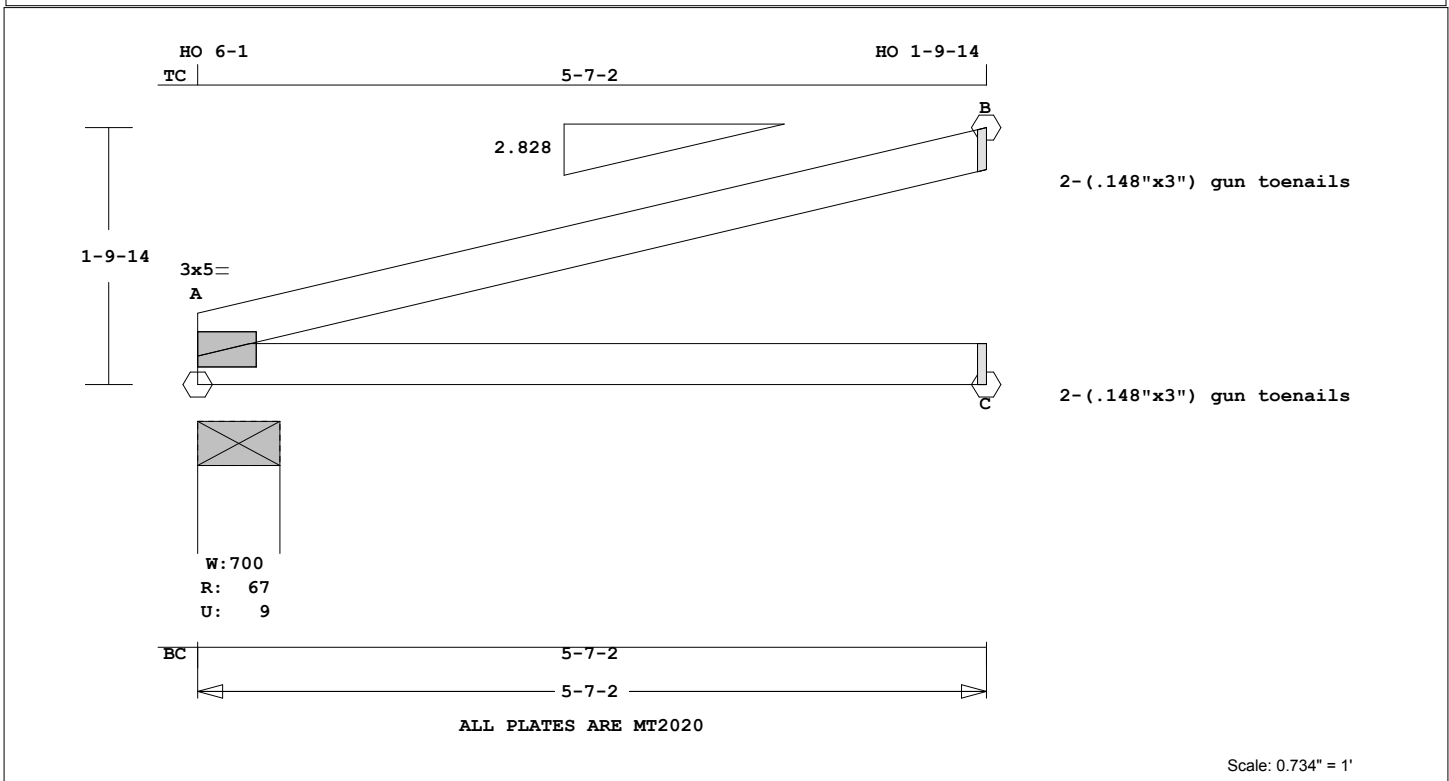

MiTek® Online Plus™ APPROX. TRUSS WEIGHT: 21.6 LBS

Online Plus -- Version 30.0.011
RUN DATE: 18-JUL-12

Southern Pine lumber design values are those effective 06-01-12 by SPIB//ALSC UON
CSI -Size- ---Lumber----
TC 0.26 2x 4 SP-#2
BC 0.15 2x 4 SP-#2

Brace truss as follows:
O.C. From To
TC Cont. 0- 0- 0 5- 7- 2
or 48.0" 0- 0- 0 5- 7- 2
BC Cont. 0- 0- 0 5- 7- 2
or 67.1" 0- 0- 0 5- 7- 2

psf-Ld	Dead	Live		
TC	7.0	20.0		
BC	10.0	0.0		
TC+BC	17.0	20.0		
Total	37.0	Spacing 24.0"		
Lumber	Duration Factor	1.25		
Plate	Duration Factor	1.25		
	Fb	Fc	Ft	Emin
TC	1.00	1.00	1.00	1.00
BC	1.00	1.00	1.00	1.00

Total Load Reactions (Lbs)
Jt Down Uplift Horiz-
A 67 10 U 26 R
C 75
B 105 58 U 15 R

Jt	Brg Size	Required
A	7.0"	1.5"
C	3.5"	1.5"
B	3.5"	1.5"

LC# 1 Girder Loading
Dur Fctrs - Lbr 1.25 Plt 1.25
plf - Dead Live* From To
TC V 14 40 0.0' 5.6'
BC V 20 0 0.0' 5.6'
TC V -14 -40 0.0' 5.6'
1 2 5.6'
BC V -20 0 0.0' 5.6'
1 0 5.6'

Plus 18 Wind Load Case(s)
Plus 1 UBC LL Load Case(s)
Plus 1 DL Load Case(s)
Membr CSI P Lbs Axl-CSI-Bnd
-----Top Chords-----
A -B 0.26 41 C 0.00 0.26
-----Bottom Chords-----
A -C 0.15 0 T 0.00 0.15

TL Defl -0.04" in A -C L/999
LL Defl -0.02" in A -C L/999
Shear // Grain in A -B 0.14

Plates for each ply each face.
Plate - MT20 20 Ga, Gross Area
Plate - MT2H 20 Ga, Gross Area
Plate - MS18 18 Ga, Gross Area
Jt Type Plt Size X Y JSI
A MT20 3.0x 5.0 0.3 Ctr 0.59

REVIEWED BY:
MiTek Industries, Inc.
6904 Parke East Blvd.
Tampa, FL 33610

REFER TO ONLINE PLUS GENERAL NOTES AND SYMBOLS SHEET FOR ADDITIONAL SPECIFICATIONS.

For proper installation of toe-nails, refer to the 2005 National Design Specification (NDS) for Wood Construction

NOTES:
Trusses Manufactured by:
RIDGWAY ROOF TRUSS
Analysis Conforms To:
FBC2010
TPI 2007
Girder King Jack
Loading TC and BC
Setback 4- 0- 0
Design checked for 10 psf non-concurrent LL on BC.
Use properly rated hangers for

loads framing into girder truss.
Wind Loads - ANSI / ASCE 7-10
Truss is designed as Components and Claddings* for Exterior zone location.
Wind Speed: 130 mph
Risk Category : II
Mean Roof Height: 25-0
Exposure Category: B
Building Type: Enclosed
TC Dead Load: 4.0 psf
BC Dead Load: 6.0 psf
Max comp. force 41 Lbs
Max tens. force 9 Lbs
Connector Plate Fabrication Tolerance = 20%
This truss is designed for a creep factor of 1.5 which is used to calculate total load deflection.

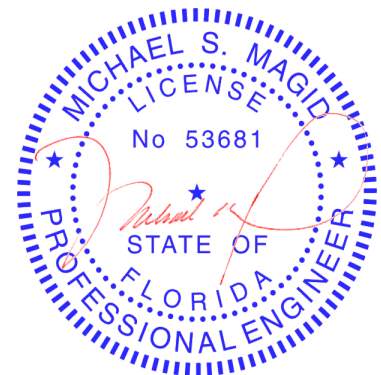

FL Cert. 6634

Job 120440	Mark R17	Quan 8	Type JACK1	Span 1111	Pl-H1 4	Left OH 0	Right OH 0	Engineering T4462844
----------------------	--------------------	-----------	---------------	--------------	------------	--------------	---------------	--------------------------------

18- Rosas- Dreambuilders

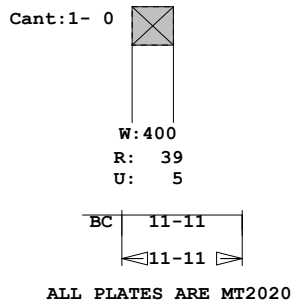
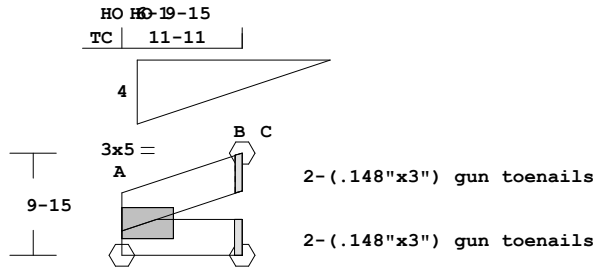

Scale: 0.643" = 1'

MiTek® Online Plus™ APPROX. TRUSS WEIGHT: 4.0 LBS

Online Plus -- Version 30.0.011
RUN DATE: 18-JUL-12

Southern Pine lumber design values are those effective 06-01-12 by SPIB//ALSC UON
CSI -Size- ----Lumber----
TC 0.01 2x 4 SP-#2
BC 0.00 2x 4 SP-#2

Brace truss as follows:

O.C.	From	To
TC Cont.	0- 0- 0	0-11-11
or 11.7"	0- 0- 0	0-11-11
BC Cont.	0- 0- 0	0-11-11
or 11.7"	0- 0- 0	0-11-11

psf-Ld	Dead	Live		
TC	7.0	20.0		
BC	10.0	0.0		
TC+BC	17.0	20.0		
Total	37.0	Spacing 24.0"		
Lumber	Duration Factor	1.25		
Plate	Duration Factor	1.25		
	Fb	Fc	Ft	Emin
TC	1.15	1.10	1.10	1.10
BC	1.10	1.10	1.10	1.10

Total Load Reactions (Lbs)

Jt	Down	Uplift	Horiz-
A	40	6 U	12 R
B	22	15 U	
C	17		7 R

Jt	Brg Size	Required
A	3.5"	1.5"
B	1.5"	1.5"
C	1.5"	1.5"

Plus 18 Wind Load Case(s)
Plus 1 UBC LL Load Case(s)
Plus 1 DL Load Case(s)

Membr	CSI	P	Lbs	Ax1	CSI-Bnd
-----Top Chords-----					
A -B	0.01		14 C	0.00	0.01
-----Bottom Chords-----					

A -C 0.00 6 T

TL Defl 0.00" in A -C L/999
LL Defl 0.00" in A -C L/999
Shear // Grain in A -B 0.03

Plates for each ply each face.
Plate - MT20 20 Ga, Gross Area
Plate - MT2H 20 Ga, Gross Area
Plate - MS18 18 Ga, Gross Area
Jt Type Plt Size X Y JSI
A MT20 3.0x 5.0 0.8 0.2 0.61

REVIEWED BY:
MiTek Industries, Inc.
6904 Parke East Blvd.
Tampa, FL 33610

REFER TO ONLINE PLUS GENERAL NOTES AND SYMBOLS SHEET FOR ADDITIONAL SPECIFICATIONS.

For proper installation of toe-nails, refer to the 2005 National Design Specification (NDS) for Wood Construction

NOTES:

Trusses Manufactured by:
RIDGWAY ROOF TRUSS

Analysis Conforms To:
FBC2010
TPI 2007

This truss has been designed for 20.0 psf LL on the B.C. in areas where a rectangle 3- 6- 0 tall by 2- 0- 0 wide will fit between the B.C. and any other member.

Design checked for 10 psf non-concurrent LL on BC.
Wind Loads - ANSI / ASCE 7-10
Truss is designed as Components and Claddings* for Exterior zone location.
Wind Speed: 130 mph

Risk Category : II
Mean Roof Height: 25-0
Exposure Category: B
Building Type: Enclosed
TC Dead Load: 4.0 psf
BC Dead Load: 6.0 psf
Max comp. force 14 Lbs
Max tens. force 6 Lbs
Connector Plate Fabrication Tolerance = 20%
This truss is designed for a creep factor of 1.5 which is used to calculate total load deflection.

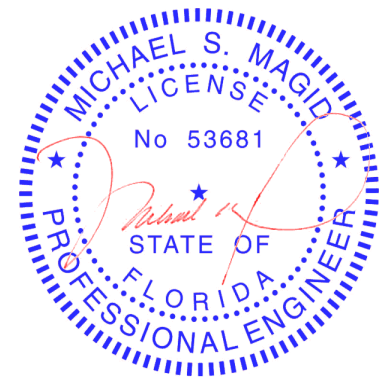

FL Cert. 6634

Job 120440	Mark R18	Quan 7	Type JACK1	Span 21111	Pl-H1 4	Left OH 0	Right OH 0	Engineering T4462845
----------------------	--------------------	-----------	---------------	---------------	------------	--------------	---------------	--------------------------------

18- Rosas- Dreambuilders

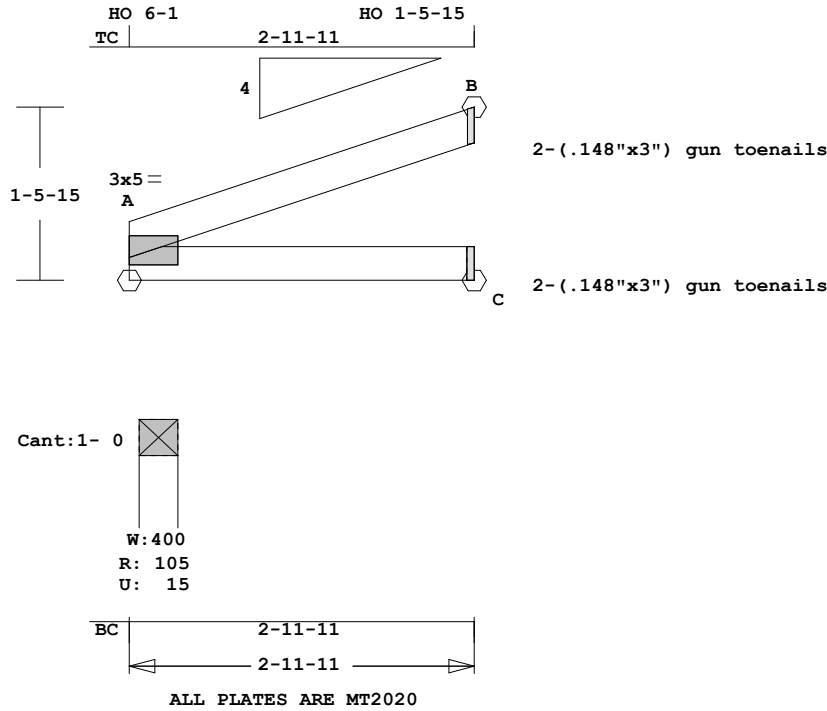

Scale: 0.604" = 1'

Online Plus -- Version 30.0.011
RUN DATE: 18-JUL-12

Southern Pine lumber design values are those effective 06-01-12 by SPIB//ALSC UON
CSI -Size- ----Lumber-----
TC 0.10 2x 4 SP-#2
BC 0.08 2x 4 SP-#2

Brace truss as follows:
O.C. From To
TC Cont. 0- 0- 0 2-11-11
or 35.7" 0- 0- 0 2-11-11
BC Cont. 0- 0- 0 2-11-11
or 35.7" 0- 0- 0 2-11-11

psf-Ld	Dead	Live		
TC	7.0	20.0		
BC	10.0	0.0		
TC+BC	17.0	20.0		
Total	37.0	Spacing 24.0"		
Lumber	Duration Factor	1.25		
Plate	Duration Factor	1.25		
	Fb	Fc	Ft	Emin
TC	1.15	1.10	1.10	1.10
BC	1.10	1.10	1.10	1.10

Total Load Reactions (Lbs)
Jt Down Uplift Horiz-
A 106 16 U 37 R
C 55
B 80 48 U 20 R

Jt	Brg Size	Required
A	4.0"	1.5"
C	3.5"	1.5"
B	3.5"	1.5"

Plus 18 Wind Load Case(s)
Plus 1 UBC LL Load Case(s)
Plus 1 DL Load Case(s)

Membr	CSI	P	Lbs	Ax1	CSI-Bnd
-----Top Chords-----					
A	-B	0.10	48	C	0.00 0.10
-----Bottom Chords-----					

MiTek® Online Plus™ APPROX. TRUSS WEIGHT: 11.7 LBS

A -C 0.08 0 T 0.00 0.08

TL Defl 0.00" in A -C L/999
LL Defl 0.00" in A -C L/999
Shear // Grain in A -B 0.12

Plates for each ply each face.
Plate - MT20 20 Ga, Gross Area
Plate - MT2H 20 Ga, Gross Area
Plate - MS18 18 Ga, Gross Area
Jt Type Plt Size X Y JSI
A MT20 3.0x 5.0 0.8 0.2 0.61

REVIEWED BY:
MiTek Industries, Inc.
6904 Parke East Blvd.
Tampa, FL 33610

REFER TO ONLINE PLUS GENERAL NOTES AND SYMBOLS SHEET FOR ADDITIONAL SPECIFICATIONS.

For proper installation of toe-nails, refer to the 2005 National Design Specification (NDS) for Wood Construction

NOTES:

Trusses Manufactured by:
RIDGWAY ROOF TRUSS

Analysis Conforms To:
FBC2010
TPI 2007

This truss has been designed for 20.0 psf LL on the B.C. in areas where a rectangle 3- 6- 0 tall by 2- 0- 0 wide will fit between the B.C. and any other member.

Design checked for 10 psf non-concurrent LL on BC.
Wind Loads - ANSI / ASCE 7-10
Truss is designed as Components and Claddings* for Exterior zone location.
Wind Speed: 130 mph

Risk Category : II
Mean Roof Height: 25-0
Exposure Category: B
Building Type: Enclosed
TC Dead Load: 4.0 psf
BC Dead Load: 6.0 psf
Max comp. force 48 Lbs
Max tens. force 11 Lbs
Connector Plate Fabrication Tolerance = 20%

This truss is designed for a creep factor of 1.5 which is used to calculate total load deflection.

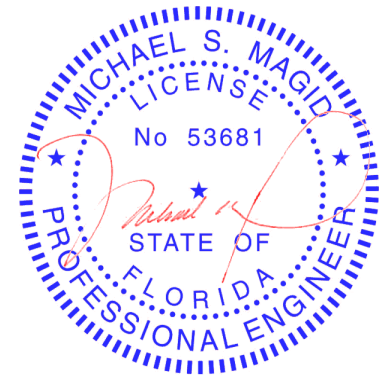

FL Cert. 6634

Job 120440	Mark R19	Quan 4	Type KING	Span 50702	P1-H1 2.828	Left OH 0	Right OH 0	Engineering T4462846
----------------------	--------------------	-----------	--------------	---------------	----------------	--------------	---------------	--------------------------------

18- Rosas- Dreambuilders

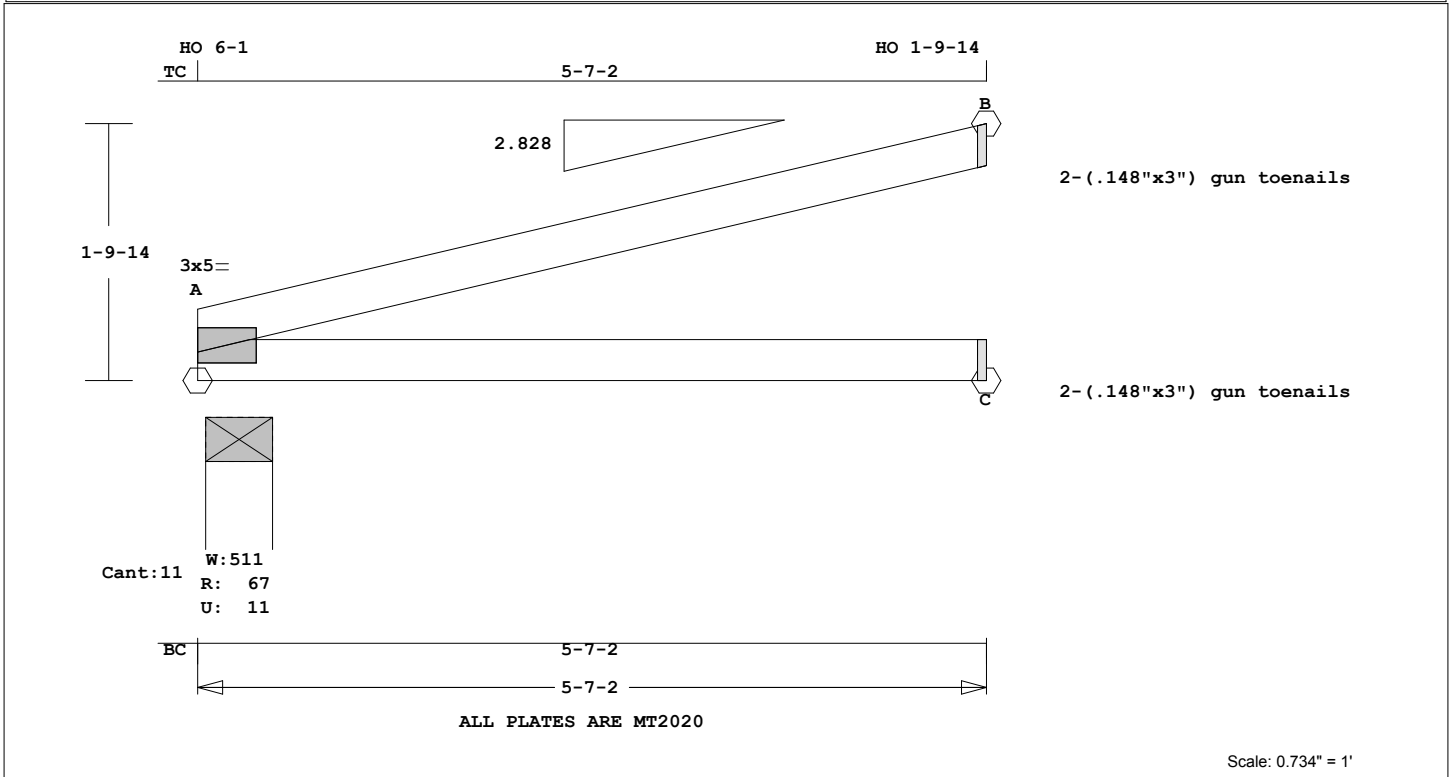

MiTek® Online Plus™ APPROX. TRUSS WEIGHT: 21.6 LBS

Online Plus -- Version 30.0.011
RUN DATE: 18-JUL-12

Southern Pine lumber design values are those effective 06-01-12 by SPIB//ALSC UON
CSI -Size- ---Lumber----
TC 0.26 2x 4 SP-#2
BC 0.15 2x 4 SP-#2

Brace truss as follows:
O.C. From To
TC Cont. 0- 0- 0 5- 7- 2
or 48.0" 0- 0- 0 5- 7- 2
BC Cont. 0- 0- 0 5- 7- 2
or 67.1" 0- 0- 0 5- 7- 2

psf-Ld	Dead	Live		
TC	7.0	20.0		
BC	10.0	0.0		
TC+BC	17.0	20.0		
Total	37.0	24.0"		
Lumber Duration Factor	1.25			
Plate Duration Factor	1.25			
	Fb	Fc	Ft	Emin
TC	1.00	1.00	1.00	1.00
BC	1.00	1.00	1.00	1.00

Total Load Reactions (Lbs)
Jt Down Uplift Horiz-
A 67 11 U 26 R
C 75
B 105 58 U 15 R

Jt	Brg Size	Required
A	5.7"	1.5"
C	3.5"	1.5"
B	3.5"	1.5"

LC# 1 Girder Loading
Dur Fctrs - Lbr 1.25 Plt 1.25
plf - Dead Live* From To
TC V 14 40 0.0' 5.6'
BC V 20 0 0.0' 5.6'
TC V -14 -40 0.0' 5.6'
1 2 5.6'
BC V -20 0 0.0' 5.6'
1 0 5.6'

Plus 18 Wind Load Case(s)
Plus 1 UBC LL Load Case(s)
Plus 1 DL Load Case(s)
Membr CSI P Lbs Axl-CSI-Bnd
-----Top Chords-----
A -B 0.26 41 C 0.00 0.26
-----Bottom Chords-----
A -C 0.15 0 T 0.00 0.15

TL Defl -0.04" in A -C L/999
LL Defl -0.02" in A -C L/999
Shear // Grain in A -B 0.14

Plates for each ply each face.
Plate - MT20 20 Ga, Gross Area
Plate - MT2H 20 Ga, Gross Area
Plate - MS18 18 Ga, Gross Area
Jt Type Plt Size X Y JSI
A MT20 3.0x 5.0 0.3 Ctr 0.59

REVIEWED BY:
MiTek Industries, Inc.
6904 Parke East Blvd.
Tampa, FL 33610

REFER TO ONLINE PLUS GENERAL NOTES AND SYMBOLS SHEET FOR ADDITIONAL SPECIFICATIONS.

For proper installation of toe-nails, refer to the 2005 National Design Specification (NDS) for Wood Construction

NOTES:
Trusses Manufactured by:
RIDGWAY ROOF TRUSS
Analysis Conforms To:
FBC2010
TPI 2007
Girder King Jack
Loading TC and BC
Setback 4- 0- 0
Design checked for 10 psf non-concurrent LL on BC.
Use properly rated hangers for

loads framing into girder truss.
Wind Loads - ANSI / ASCE 7-10
Truss is designed as Components and Claddings* for Exterior zone location.
Wind Speed: 130 mph
Risk Category : II
Mean Roof Height: 25-0
Exposure Category: B
Building Type: Enclosed
TC Dead Load: 4.0 psf
BC Dead Load: 6.0 psf
Max comp. force 41 Lbs
Max tens. force 9 Lbs
Connector Plate Fabrication Tolerance = 20%
This truss is designed for a creep factor of 1.5 which is used to calculate total load deflection.

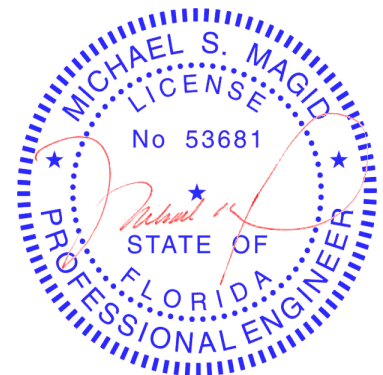

FL Cert. 6634

Job 120440	Mark R20	Quan 10	Type MONO	Span 40000	Pl-H1 4	Left OH 0	Right OH 0	Engineering T4462847
----------------------	--------------------	------------	--------------	---------------	------------	--------------	---------------	--------------------------------

18- Rosas- Dreambuilders

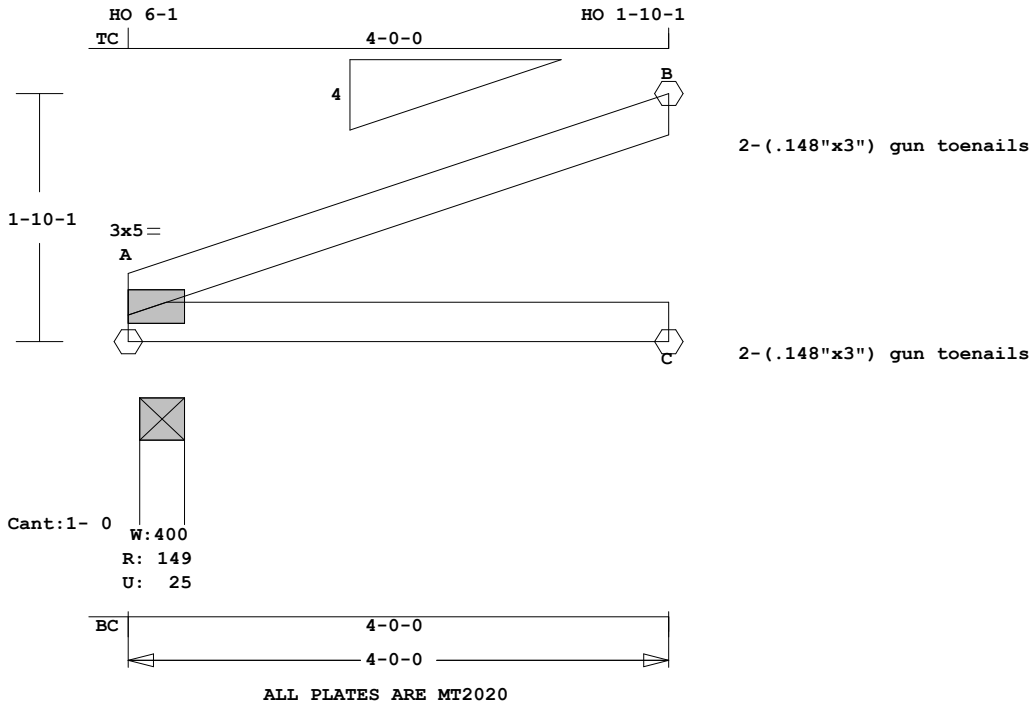

Scale: 0.703" = 1'

MiTek® Online Plus™ APPROX. TRUSS WEIGHT: 15.7 LBS

Online Plus -- Version 30.0.011
RUN DATE: 18-JUL-12

Southern Pine lumber design values are those effective 06-01-12 by SPIB//ALSC UON
CSI -Size- ----Lumber-----
TC 0.23 2x 4 SP-#2
BC 0.16 2x 4 SP-#2

Brace truss as follows:
O.C. From To
TC Cont. 0- 0- 0 4- 0- 0
or 48.0" 0- 0- 0 4- 0- 0
BC Cont. 0- 0- 0 4- 0- 0
or 48.0" 0- 0- 0 4- 0- 0

psf-Ld	Dead	Live		
TC	7.0	20.0		
BC	10.0	0.0		
TC+BC	17.0	20.0		
Total	37.0	Spacing 24.0"		
Lumber	Duration Factor	1.25		
Plate	Duration Factor	1.25		
	Fb	Fc	Ft	Emin
TC	1.15	1.10	1.10	1.10
BC	1.10	1.10	1.10	1.10

Total Load Reactions (Lbs)
Jt Down Uplift Horiz-
A 150 25 U 50 R
C 72
B 100 58 U 27 R

Jt	Brg Size	Required
A	4.0"	1.5"
C	1.5"	1.5"
B	1.5"	1.5"

Plus 18 Wind Load Case(s)
Plus 1 UBC LL Load Case(s)
Plus 1 DL Load Case(s)

Membr	CSI	P	Lbs	Ax1	CSI-Bnd
-----Top Chords-----					
A -B	0.23	58	C	0.00	0.23
-----Bottom Chords-----					

A -C 0.16 0 T 0.00 0.16

TL Defl -0.02" in A -C L/999
LL Defl -0.01" in A -C L/999
Shear // Grain in A -B 0.15

Plates for each ply each face.
Plate - MT20 20 Ga, Gross Area
Plate - MT2H 20 Ga, Gross Area
Plate - MS18 18 Ga, Gross Area
Jt Type Plt Size X Y JSI
A MT20 3.0x 5.0 0.8 0.2 0.61

REVIEWED BY:
MiTek Industries, Inc.
6904 Parke East Blvd.
Tampa, FL 33610

REFER TO ONLINE PLUS GENERAL NOTES AND SYMBOLS SHEET FOR ADDITIONAL SPECIFICATIONS.

For proper installation of toe-nails, refer to the 2005 National Design Specification (NDS) for Wood Construction

NOTES:

Trusses Manufactured by:
RIDGWAY ROOF TRUSS

Analysis Conforms To:
FBC2010
TPI 2007

This truss has been designed for 20.0 psf LL on the B.C. in areas where a rectangle 3- 6- 0 tall by 2- 0- 0 wide will fit between the B.C. and any other member.

Design checked for 10 psf non-concurrent LL on BC.
Wind Loads - ANSI / ASCE 7-10
Truss is designed as Components and Claddings* for Exterior zone location.
Wind Speed: 130 mph

Risk Category : II
Mean Roof Height: 25-0
Exposure Category: B
Building Type: Enclosed
TC Dead Load: 4.0 psf
BC Dead Load: 6.0 psf
Max comp. force 58 Lbs
Max tens. force 16 Lbs
Connector Plate Fabrication Tolerance = 20%
This truss is designed for a creep factor of 1.5 which is used to calculate total load deflection.

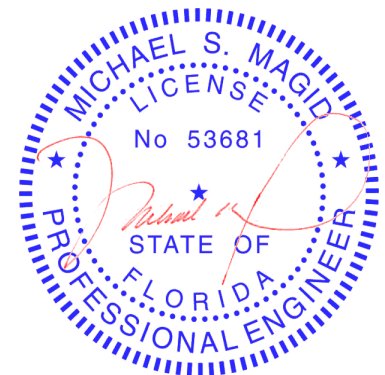

FL Cert. 6634

Job 120440	Mark R21	Quan 1	Type HHIP	Span 140000	Pl-H1 4	Left OH 0	Right OH 0	Engineering T4462848
----------------------	--------------------	-----------	--------------	----------------	------------	--------------	---------------	--------------------------------

18- Rosas- Dreambuilders

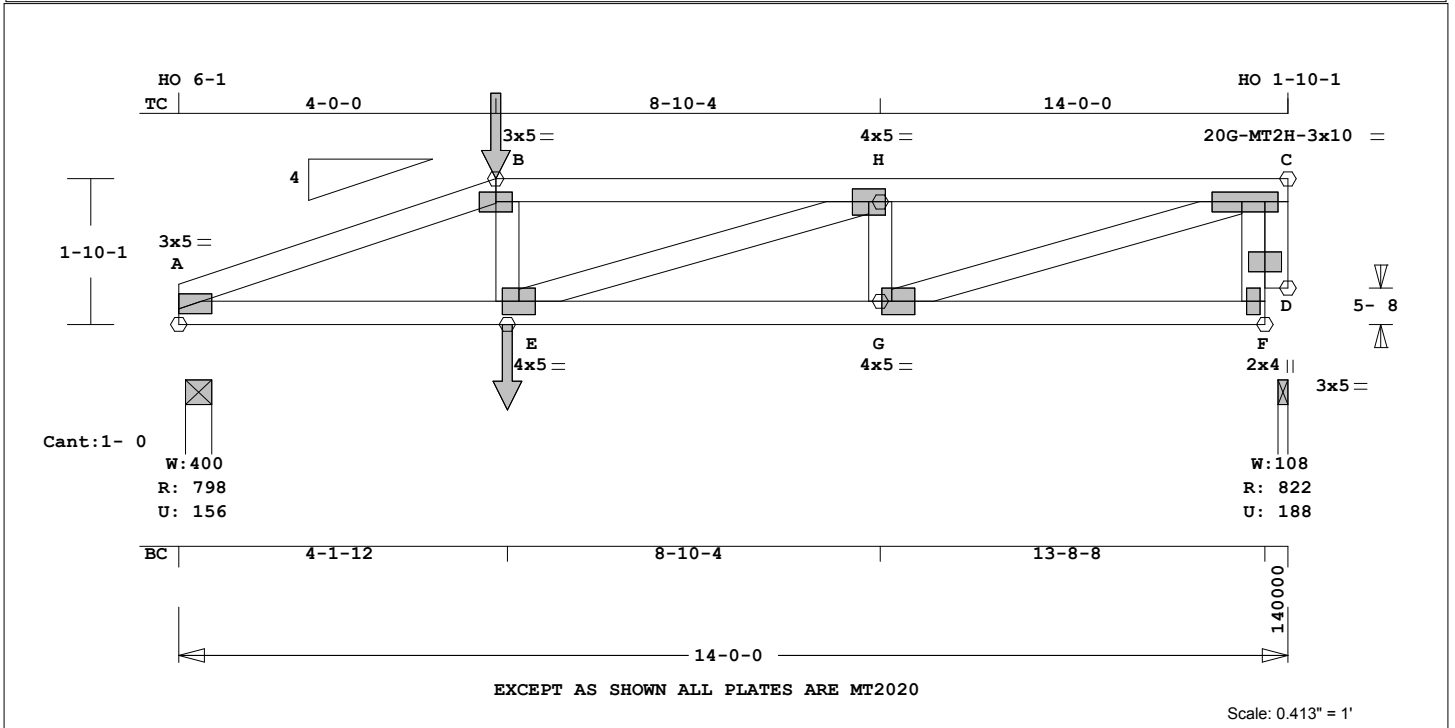

EXCEPT AS SHOWN ALL PLATES ARE MT2020

Scale: 0.413" = 1'

Online Plus -- Version 30.0.011
RUN DATE: 18-JUL-12

Southern Pine lumber design values are those effective 06-01-12 by SPIB//ALSC UON
CSI -Size- Lumber-----
TC 0.47 2x 4 SP-#2
BC 0.50 2x 4 SP-#1
WB 0.74 2x 4 SP-#3
BB --- 2x 4 SP-#3

Brace truss as follows:
O.C. From To
TC Cont. 0- 0- 0 14- 0- 0
or 42.0" 0- 0- 0 14- 0- 0
BC Cont. 0- 0- 0 14- 0- 0
or 96.0" 0- 0- 0 14- 0- 0

psf-Ld Dead Live
TC 7.0 20.0
BC 10.0 0.0
TC+BC 17.0 20.0
Total 37.0 Spacing 24.0"
Lumber Duration Factor 1.25
Plate Duration Factor 1.25
Fb Fc Ft Emin
TC 1.00 1.00 1.00 1.00
BC 1.00 1.00 1.00 1.00

Total Load Reactions (Lbs)
Jt Down Uplift Horiz-
A 799 156 U 197 R
D 823 189 U 199 R

Jt Brg Size Required
A 4.0" 1.5"
D 1.5" 1.5"

LC# 1 Standard Loading
Dur Fctrs - Lbr 1.25 Plt 1.25
plf - Dead Live* From To
TC V 14 40 0.0' 14.0'
BC V 20 0 0.0' 14.0'
TC V 7 20 4.0' 13.7'
BC V 10 0 4.0' 13.7'
TC V 92 62 4.0' CL-LB
BC V 47 31 4.1' CL-LB

Plus 21 Wind Load Case(s)
Plus 1 UBC LL Load Case(s)
Plus 1 DL Load Case(s)

Membr CSI P Lbs Ax1-CSI-Bnd

MiTek® Online Plus™ APPROX. TRUSS WEIGHT: 79.5 LBS

-----Top Chords-----
A -B 0.47 1717 C 0.05 0.42
B -H 0.43 1617 C 0.04 0.39
H -C 0.46 1748 C 0.05 0.41
C -C 0.01 0 T 0.00 0.01
-----Bottom Chords-----
A -E 0.50 1617 T 0.23 0.27
E -G 0.39 1748 T 0.25 0.14
G -F 0.12 115 C 0.00 0.12
-----Webs-----
E -B 0.06 204 T
E -H 0.08 161 C
G -H 0.10 403 C
G -C 0.74 1839 T
F -D 0.32 102 T 0.02 0.30
D -C 0.32 757 C 0.01 0.31

TL Defl -0.19" in E -G L/837
LL Defl -0.08" in E -G L/999
Shear // Grain in H -C 0.29

Plates for each ply each face.
Plate - MT20 20 Ga, Gross Area
Plate - MT2H 20 Ga, Gross Area
Plate - MS18 18 Ga, Gross Area
Jt Type Plt Size X Y JSI
A MT20 3.0x 5.0 0.8 0.2 0.71
B MT20 3.0x 5.0 Ctr Ctr 0.77
H MT20 4.0x 5.0 Ctr Ctr 0.14
C MT2H 3.0x10.0 0.5 Ctr 0.98
E MT20 4.0x 5.0 Ctr Ctr 0.10
G MT20 4.0x 5.0 1.0 Ctr 0.97
F MT20 2.0x 4.0 Ctr Ctr 0.12
D MT20 3.0x 5.0 Ctr Ctr 0.00

REVIEWED BY:
MiTek Industries, Inc.
6904 Parke East Blvd.
Tampa, FL 33610

REFER TO ONLINE PLUS GENERAL NOTES AND SYMBOLS SHEET FOR ADDITIONAL SPECIFICATIONS.

NOTES:
Trusses Manufactured by:
RIDGWAY ROOF TRUSS

Analysis Conforms To:
FBC2010
TPI 2007

This truss has been designed for 20.0 psf LL on the B.C. in areas where a rectangle 3- 6- 0 tall by

2- 0- 0 wide will fit between the B.C. and any other member.
Design checked for 10 psf non-concurrent LL on BC.
Max gap between edge of brg and end vertical or diagonal web is 1/2".
Wind Loads - ANSI / ASCE 7-10
Truss is designed as Components and Claddings* for Exterior zone location.
Wind Speed: 130 mph
Risk Category : II
Mean Roof Height: 25-0
Exposure Category: B
Building Type: Enclosed
TC Dead Load: 4.0 psf
BC Dead Load: 6.0 psf
Max comp. force 1748 Lbs
Max tens. force 1839 Lbs
Connector Plate Fabrication Tolerance = 20%
This truss is designed for a creep factor of 1.5 which is used to calculate total load deflection.

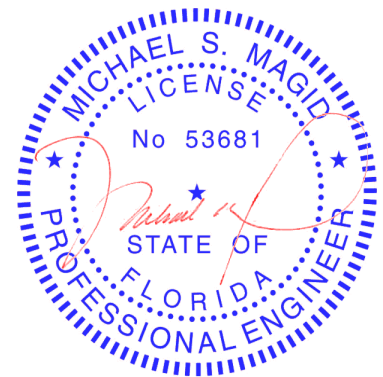

FL Cert. 6634

July 18, 2012

Job 120440	Mark R22	Quan 1	Type HHIP	Span 140000	Pl-H1 4	Left OH 0	Right OH 0	Engineering T4462849
----------------------	--------------------	-----------	--------------	----------------	------------	--------------	---------------	--------------------------------

18- Rosas- Dreambuilders

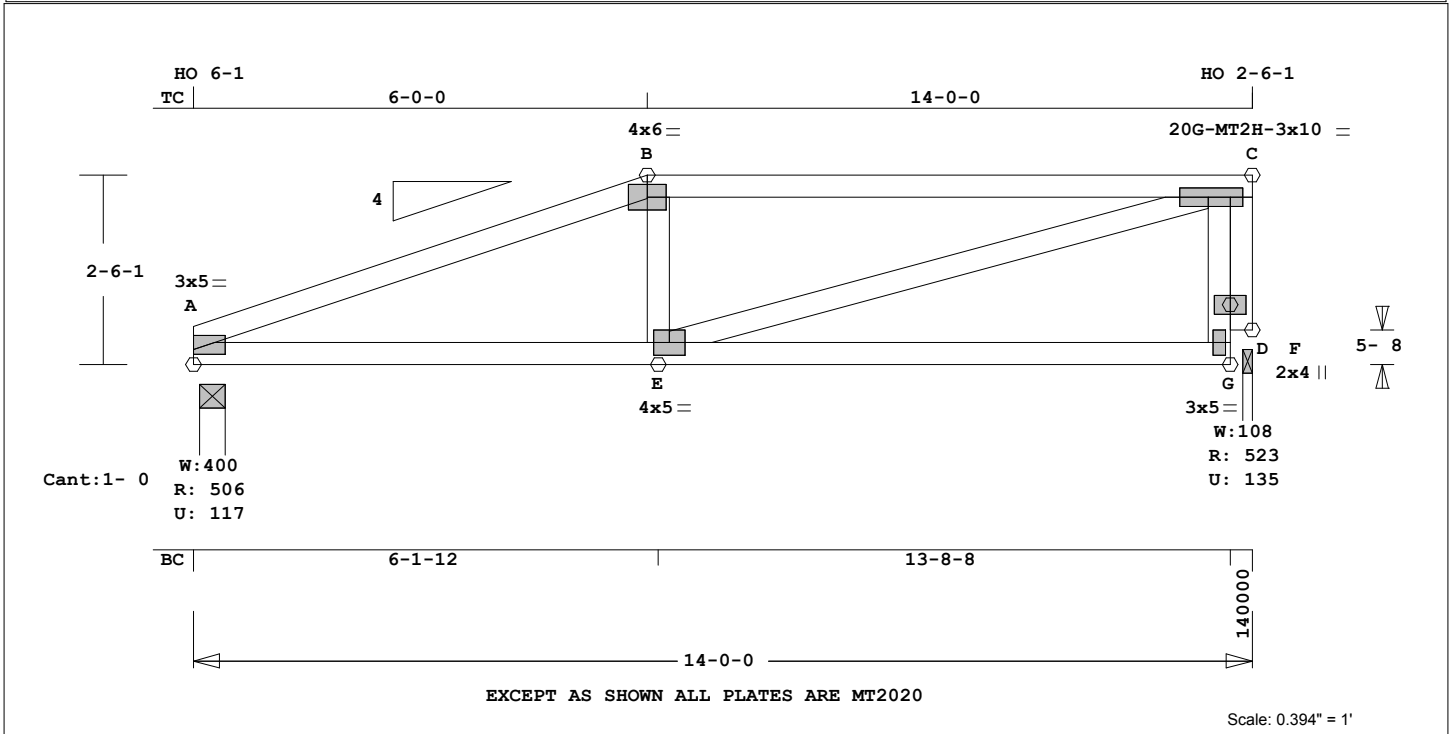

Online Plus -- Version 30.0.011
RUN DATE: 18-JUL-12

Southern Pine lumber design values are those effective

06-01-12 by SPIB//ALSC UON

	CSI	-Size-	Lumber
TC	0.51	2x 4	SP-#1
--	0.30	2x 4	SP-#2
A -B			
BC	0.44	2x 4	SP-#2
WB	0.50	2x 4	SP-#3
BB	---	2x 4	SP-#3

Brace truss as follows:

	O.C.	From	To
TC	Cont.	0- 0- 0	14- 0- 0
or	48.0"	0- 0- 0	14- 0- 0
BC	Cont.	0- 0- 0	14- 0- 0
or	120.0"	0- 0- 0	14- 0- 0

psf-ld	Dead	Live		
TC	7.0	20.0		
BC	10.0	0.0		
TC+BC	17.0	20.0		
Total	37.0	Spacing 24.0"		
Lumber	Duration Factor	1.25		
Plate	Duration Factor	1.25		
	Fb	Fc	Ft	Emin
TC	1.15	1.10	1.10	1.10
BC	1.10	1.10	1.10	1.10

Total Load Reactions (Lbs)

Jt	Down	Uplift	Horiz-
A	507	118 U	87 R
G	523	136 U	84 R

Jt	Brg Size	Required
A	4.0"	1.5"
G	1.5"	1.5"

Plus 21 Wind Load Case(s)
Plus 1 UBC LL Load Case(s)
Plus 1 DL Load Case(s)

Membr	CSI	P	Lbs	Ax1	CSI	Bnd
-----Top Chords-----						
A -B	0.30	893	C	0.01	0.29	
B -C	0.51	846	C	0.01	0.50	

MiTek® Online Plus™ APPROX. TRUSS WEIGHT: 77.7 LBS

C -C	0.00	0 T
-----Bottom Chords-----		
A -E	0.44	846 T 0.11 0.33
E -F	0.43	59 C 0.00 0.43
-----Webs-----		
E -B	0.07	221 T
E -C	0.50	883 T
F -G	0.17	128 T 0.02 0.15
G -C	0.18	457 C 0.08 0.10
TL Defl	-0.24"	in E -F L/661
LL Defl	-0.11"	in E -F L/999
Shear // Grain		in B -C 0.27

Plates for each ply each face.
Plate - MT20 20 Ga, Gross Area
Plate - MT2H 20 Ga, Gross Area
Plate - MS18 18 Ga, Gross Area
Jt Type Plt Size X Y JSI
A MT20 3.0x 5.0 0.8 0.2 0.61
B MT20 4.0x 6.0 Ctr Ctr 0.78
C MT2H 3.0x10.0 0.5 Ctr 0.48
E MT20 4.0x 5.0 Ctr Ctr 0.52
F MT20 2.0x 4.0 Ctr Ctr 0.12
G MT20 3.0x 5.0 Ctr Ctr 0.00

REVIEWED BY:
MiTek Industries, Inc.
6904 Parke East Blvd.
Tampa, FL 33610

REFER TO ONLINE PLUS GENERAL NOTES AND SYMBOLS SHEET FOR ADDITIONAL SPECIFICATIONS.

NOTES:
Trusses Manufactured by:
RIDGWAY ROOF TRUSS
Analysis Conforms To:
FBC2010
TPI 2007

This truss has been designed for 20.0 psf LL on the B.C. in areas where a rectangle 3- 6- 0 tall by 2- 0- 0 wide will fit between the B.C. and any other member.
Design checked for 10 psf non-

concurrent LL on BC.
Max gap between edge of brg and end vertical or diagonal web is 1/2".
Wind Loads - ANSI / ASCE 7-10
Truss is designed as Components and Claddings* for Exterior zone location.
Wind Speed: 130 mph
Risk Category : II
Mean Roof Height: 25-0
Exposure Category: B
Building Type: Enclosed
TC Dead Load: 4.0 psf
BC Dead Load: 6.0 psf
Max comp. force 893 Lbs
Max tens. force 883 Lbs
Connector Plate Fabrication Tolerance = 20%
This truss is designed for a creep factor of 1.5 which is used to calculate total load deflection.

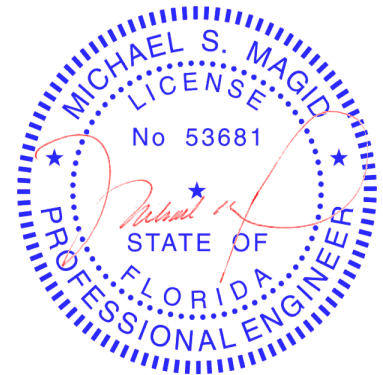

FL Cert. 6634

Job 120440	Mark R23	Quan 13	Type MONO	Span 70600	P1-H1 4	Left OH 0	Right OH 0	Engineering T4462850
----------------------	--------------------	------------	--------------	---------------	------------	--------------	---------------	--------------------------------

18- Rosas- Dreambuilders

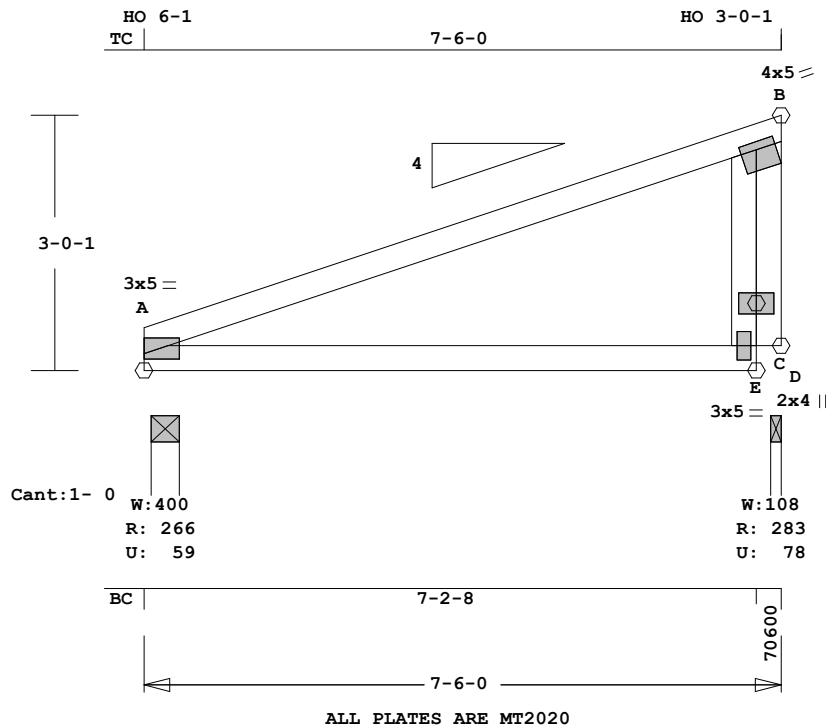

Scale: 0.442" = 1'

MiTek® Online Plus™ APPROX. TRUSS WEIGHT: 37.6 LBS

Online Plus -- Version 30.0.011
RUN DATE: 18-JUL-12

Southern Pine lumber design values are those effective

CSI	-Size-	Lumber	---
TC	0.47	2x 4	SP-#2
BC	0.33	2x 4	SP-#2
WB	0.65	2x 4	SP-#2
BB	---	2x 4	SP-#3

Brace truss as follows:

O.C.	From	To
TC Cont.	0- 0- 0	7- 6- 0
or	48.0"	0- 0- 0
BC Cont.	0- 0- 0	7- 6- 0
or	86.5"	0- 0- 0

psf-Ld	Dead	Live		
TC	7.0	20.0		
BC	10.0	0.0		
TC+BC	17.0	20.0		
Total	37.0	24.0"		
Lumber	Duration Factor	1.25		
Plate	Duration Factor	1.25		
	Fb	Fc	Ft	Emin
TC	1.15	1.10	1.10	1.10
BC	1.10	1.10	1.10	1.10

Total Load Reactions (Lbs)

Jt	Down	Uplift	Horiz-
A	266	59 U	83 R
E	283	79 U	153 R

Jt	Brg Size	Required
A	4.0"	1.5"
E	1.5"	1.5"

Plus 18 Wind Load Case(s)
Plus 1 UBC LL Load Case(s)
Plus 1 DL Load Case(s)

Membr	CSI	P	Lbs	Ax1	CSI-Bnd
-----Top Chords-----					
A	-B	0.47	145	C	0.00 0.47
B	-B	0.01	3	C	0.00 0.01

-----Bottom Chords-----					
A	-D	0.33	138	T	0.02 0.31
-----Webs-----					
D	-E	0.43	156	T	0.02 0.41
E	-B	0.65	252	T	0.00 0.65

TL Defl -0.11" in A -D L/731
LL Defl -0.05" in A -D L/999
Shear // Grain in A -B 0.25

Plates for each ply each face.
Plate - MT20 20 Ga, Gross Area
Plate - MT2H 20 Ga, Gross Area
Plate - MS18 18 Ga, Gross Area
Jt Type Plt Size X Y JSI
A MT20 3.0x 5.0 0.8 0.2 0.61
B MT20 4.0x 5.0 0.5-0.8 0.15
D MT20 2.0x 4.0 Ctr Ctr 0.13
E MT20 3.0x 5.0 Ctr Ctr 0.00

REVIEWED BY:
MiTek Industries, Inc.
6904 Parke East Blvd.
Tampa, FL 33610

REFER TO ONLINE PLUS GENERAL NOTES AND SYMBOLS SHEET FOR ADDITIONAL SPECIFICATIONS.

NOTES:

Trusses Manufactured by:
RIDGWAY ROOF TRUSS
Analysis Conforms To:
FBC2010
TPI 2007
This truss has been designed for 20.0 psf LL on the B.C. in areas where a rectangle 3- 6- 0 tall by 2- 0- 0 wide will fit between the B.C. and any other member. Design checked for 10 psf non-concurrent LL on BC. Max gap between edge of brg and end vertical or diagonal web is 1/2".

Wind Loads - ANSI / ASCE 7-10
Truss is designed as

Components and Claddings*
for Exterior zone location.
Wind Speed: 130 mph
Risk Category : II
Mean Roof Height: 25-0
Exposure Category: B
Building Type: Enclosed
TC Dead Load: 4.0 psf
BC Dead Load: 6.0 psf
Max comp. force 181 Lbs
Max tens. force 252 Lbs
Connector Plate Fabrication Tolerance = 20%
This truss is designed for a creep factor of 1.5 which is used to calculate total load deflection.

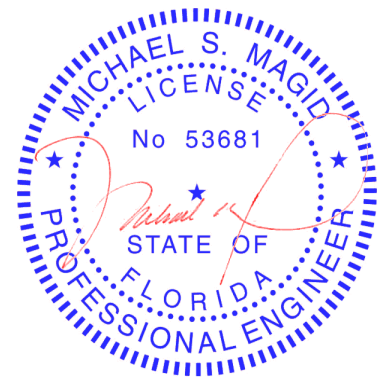

FL Cert. 6634

Job 120440	Mark R23A	Quan 1	Type MONO	Span 70600	P1-H1 4	Left OH 0	Right OH 0	Engineering T4462851
----------------------	---------------------	-----------	--------------	---------------	------------	--------------	---------------	--------------------------------

18- Rosas- Dreambuilders

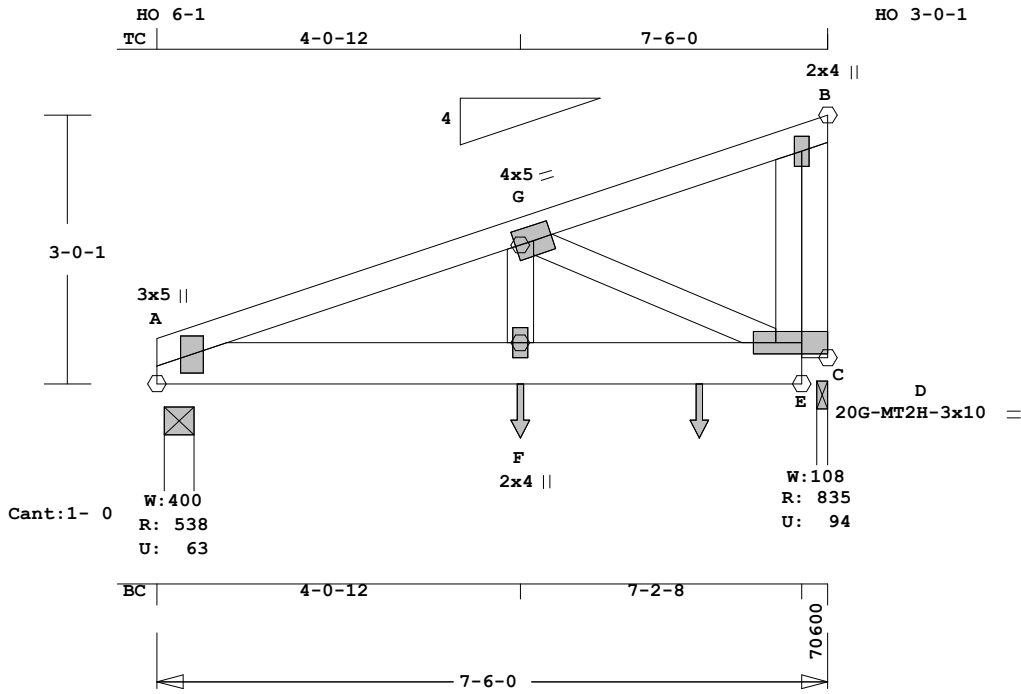

EXCEPT AS SHOWN ALL PLATES ARE MT2020

Scale: 0.466" = 1'

MiTek® Online Plus™ APPROX. TRUSS WEIGHT: 51.8 LBS

Online Plus -- Version 30.0.011
RUN DATE: 18-JUL-12

Southern Pine lumber design values are those effective 06-01-12 by SPIB//ALSC UON
CSI -Size- ---Lumber---
TC 0.17 2x 4 SP-#2
BC 0.35 2x 6 SP-#2
WB 0.35 2x 4 SP-#3

Brace truss as follows:
O.C. From To
TC Cont. 0- 0- 0 7- 6- 0
or 48.0" 0- 0- 0 7- 6- 0
BC Cont. 0- 0- 0 7- 6- 0
or 90.0" 0- 0- 0 7- 6- 0

psf-Ld	Dead	Live
TC	7.0	20.0
BC	10.0	0.0
TC+BC	17.0	20.0
Total	37.0	Spacing 24.0"
Lumber	Duration Factor	1.25
Plate	Duration Factor	1.25
	Fb	Fc Ft Emin
TC	1.00	1.00 1.00 1.00
BC	1.00	1.00 1.00 1.00

Total Load Reactions (Lbs)
Jt Down Uplift Horiz-
A 538 64 U 40 R
D 836 94 U 85 R

Jt	Brg Size	Required
A	4.0"	1.5"
D	1.5"	1.5"

LC# 1 Standard Loading
Dur Fctrs - Lbr 1.25 Plt 1.25
plf - Dead Live* From To
TC V 14 40 0.0' 7.5'
BC V 20 0 0.0' 7.5'
BC V 281 187 4.1' CL-LB
BC V 214 143 6.1' CL-LB

Plus 18 Wind Load Case(s)
Plus 1 UBC LL Load Case(s)
Plus 1 DL Load Case(s)

Membr	CSI	P	Lbs	Axl	CSI	Bnd
-----Top Chords-----						
A -G	0.17	1070	C	0.05	0.12	
G -B	0.15	78	C	0.00	0.15	
-----Bottom Chords-----						
A -F	0.16	1014	T	0.13	0.03	
F -D	0.35	1014	T	0.13	0.22	
-----Webs-----						
F -G	0.25	706	T			
G -D	0.35	1120	C			
D -B	0.03	84	T	WindLd		
D -B	0.03	84	T			

TL Defl -0.03" in A -F L/999
LL Defl -0.01" in A -F L/999
Shear // Grain in F -D 0.22

Plates for each ply each face.
Plate - MT20 20 Ga, Gross Area
Plate - MT2H 20 Ga, Gross Area
Plate - MS18 18 Ga, Gross Area
Jt Type Plt Size X Y JSI
A MT20 3.0x 5.0 Ctr Ctr 0.60
G MT20 4.0x 5.0 Ctr Ctr 0.38
B MT20 2.0x 4.0 Ctr Ctr 0.39
F MT20 2.0x 4.0 Ctr Ctr 0.65
D MT2H 3.0x10.0-1.5 Ctr 0.67

REVIEWED BY:
MiTek Industries, Inc.
6904 Parke East Blvd.
Tampa, FL 33610

REFER TO ONLINE PLUS GENERAL NOTES AND SYMBOLS SHEET FOR ADDITIONAL SPECIFICATIONS.

NOTES:
Trusses Manufactured by:
RIDGWAY ROOF TRUSS
Analysis Conforms To:
FBC2010
TPI 2007
This truss has been designed for 20.0 psf LL on the B.C. in areas where a rectangle 3- 6- 0 tall by 2- 0- 0 wide will fit between the B.C. and any other member.

Design checked for 10 psf non-concurrent LL on BC.
Wind Loads - ANSI / ASCE 7-10
Truss is designed as Components and Claddings* for Exterior zone location.
Wind Speed: 130 mph
Risk Category : II
Mean Roof Height: 25-0
Exposure Category: B
Building Type: Enclosed
TC Dead Load: 4.0 psf
BC Dead Load: 6.0 psf
Max comp. force 1120 Lbs
Max tens. force 1014 Lbs
Connector Plate Fabrication Tolerance = 20%
This truss is designed for a creep factor of 1.5 which is used to calculate total load deflection.

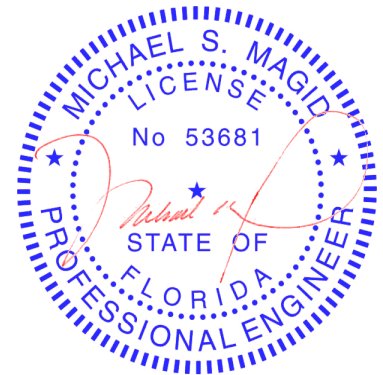

FL Cert. 6634

Job 120440	Mark R32	Quan 1	Type HHIP	Span 71000	P1-H1 4	Left OH 0	Right OH 0	Engineering T4462852
----------------------	--------------------	-----------	--------------	---------------	------------	--------------	---------------	--------------------------------

18- Rosas- Dreambuilders

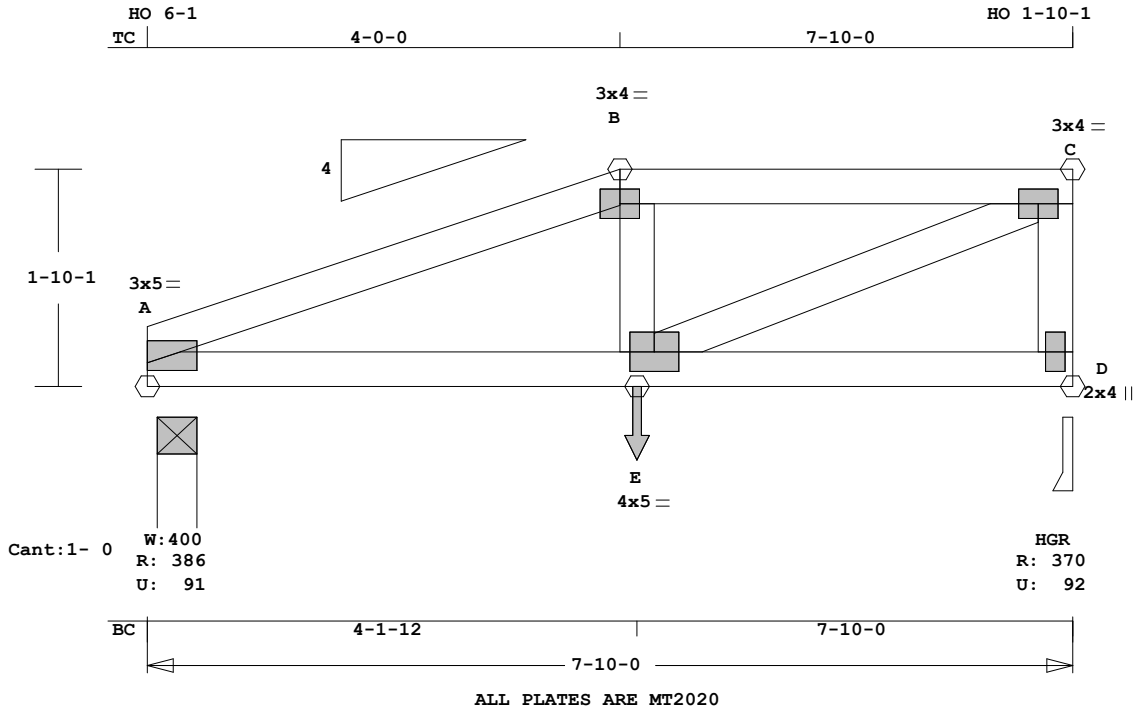

Scale: 0.615" = 1'

MiTek® Online Plus™ APPROX. TRUSS WEIGHT: 41.5 LBS

Online Plus -- Version 30.0.011
RUN DATE: 18-JUL-12

Southern Pine lumber design values are those effective 06-01-12 by SPIB//ALSC UON
CSI -Size- ---Lumber---
TC 0.30 2x 4 SP-#2
BC 0.26 2x 4 SP-#2
WB 0.27 2x 4 SP-#3

Brace truss as follows:
O.C. From To
TC Cont. 0- 0- 0 7-10- 0
or 48.0" 0- 0- 0 7-10- 0
BC Cont. 0- 0- 0 7-10- 0
or 94.0" 0- 0- 0 7-10- 0

psf-Ld Dead Live
TC 7.0 20.0
BC 10.0 0.0
TC+BC 17.0 20.0
Total 37.0 Spacing 24.0"
Lumber Duration Factor 1.25
Plate Duration Factor 1.25
Fb Fc Ft Emin
TC 1.00 1.00 1.00 1.00
BC 1.00 1.00 1.00 1.00

Total Load Reactions (Lbs)
Jt Down Uplift Horiz-
A 387 92 U 19 R
D 370 92 U 49 R

Jt Brg Size Required
A 4.0" 1.5"
D 3.5" 1.5"

LC# 1 Girder Loading
Dur Fctrs - Lbr 1.25 Plt 1.25
plf - Dead Live* From To
TC V 14 40 0.0' 7.8'
BC V 20 0 0.0' 7.8'
TC V 7 20 4.0' 6.8'
TC V -14 -40 6.8' 7.8'
BC V 10 0 4.1' 6.8'
BC V -20 0 6.8' 7.8'
BC V 68 80 4.1' CL-LB

Plus 21 Wind Load Case(s)

Plus 1 UBC LL Load Case(s)
Plus 1 DL Load Case(s)

Membr	CSI	P	Lbs	Axl	CSI-Bnd
-----Top Chords-----					
A -B	0.26	650	C	0.08	0.18
B -C	0.30	612	C	0.08	0.22
-----Bottom Chords-----					
A -E	0.26	612	T	0.14	0.12
E -D	0.13	37	T	0.00	0.13
-----Webs-----					
E -B	0.06	189	T		
E -C	0.27	668	T		
D -C	0.10	340	C	WindLd	

TL Defl -0.03" in E -D L/999
LL Defl -0.01" in E -D L/999
Shear // Grain in B -C 0.17

Plates for each ply each face.
Plate - MT20 20 Ga, Gross Area
Plate - MT2H 20 Ga, Gross Area
Plate - MS18 18 Ga, Gross Area
Jt Type Plt Size X Y JSI
A MT20 3.0x 5.0 0.8 0.2 0.61
B MT20 3.0x 4.0 Ctr Ctr 0.86
C MT20 3.0x 4.0 Ctr Ctr 0.80
E MT20 4.0x 5.0 Ctr Ctr 0.36
D MT20 2.0x 4.0 Ctr Ctr 0.25

REVIEWED BY:
MiTek Industries, Inc.
6904 Parke East Blvd.
Tampa, FL 33610

REFER TO ONLINE PLUS GENERAL NOTES AND SYMBOLS SHEET FOR ADDITIONAL SPECIFICATIONS.

NOTES:
Trusses Manufactured by:
RIDGWAY ROOF TRUSS
Analysis Conforms To:
FBC2010
TPI 2007
Girder Half Hip
Framing King Jacks
Jack Open Faced
Setback 4- 0- 0

Design checked for 10 psf non-

concurrent LL on BC.
Wind Loads - ANSI / ASCE 7-10
Truss is designed as
Components and Claddings*
for Exterior zone location.
Wind Speed: 130 mph
Risk Category : II
Mean Roof Height: 25-0
Exposure Category: B
Building Type: Enclosed
TC Dead Load: 4.0 psf
BC Dead Load: 6.0 psf
Max comp. force 650 Lbs
Max tens. force 668 Lbs
Connector Plate Fabrication
Tolerance = 20%
This truss is designed for a
creep factor of 1.5 which
is used to calculate total
load deflection.

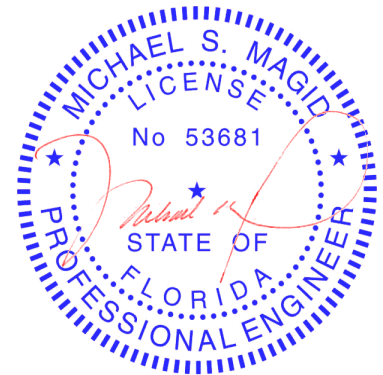

FL Cert. 6634

July 18, 2012

Job 120440	Mark R33	Quan 1	Type HHIP	Span 71000	Pl-H1 4	Left OH 0	Right OH 0	Engineering T4462853
----------------------	--------------------	-----------	--------------	---------------	------------	--------------	---------------	--------------------------------

18- Rosas- Dreambuilders

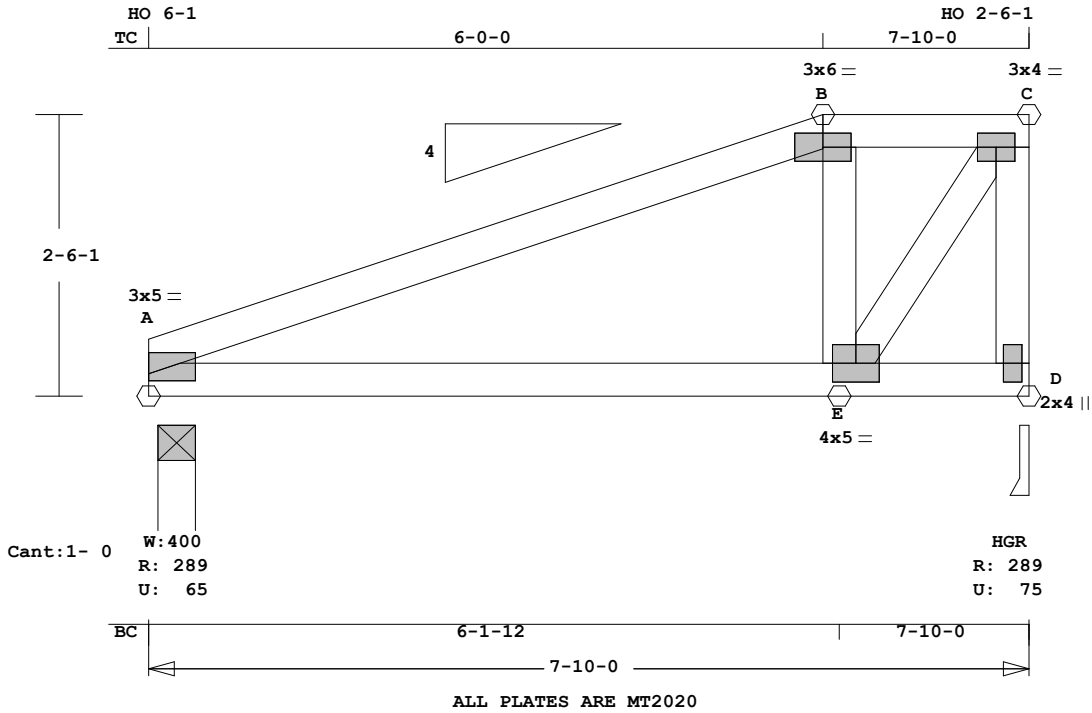

Scale: 0.585" = 1'

Online Plus -- Version 30.0.011
RUN DATE: 18-JUL-12

Southern Pine lumber design values are those effective
06-01-12 by SPIB//ALSC UON
CSI -Size- ---Lumber---
TC 0.37 2x 4 SP-#2
BC 0.25 2x 4 SP-#2
WB 0.16 2x 4 SP-#3

Brace truss as follows:
O.C. From To
TC Cont. 0- 0- 0 7-10- 0
or 48.0" 0- 0- 0 7-10- 0
BC Cont. 0- 0- 0 7-10- 0
or 94.0" 0- 0- 0 7-10- 0

psf-Ld	Dead	Live		
TC	7.0	20.0		
BC	10.0	0.0		
TC+BC	17.0	20.0		
Total	37.0	Spacing 24.0"		
Lumber	Duration Factor	1.25		
Plate	Duration Factor	1.25		
	Fb	Fc	Ft	Emin
TC	1.15	1.10	1.10	1.10
BC	1.10	1.10	1.10	1.10

Total Load Reactions (Lbs)

Jt	Down	Uplift	Horiz-
A	290	65 U	29 R
D	290	75 U	72 R

Jt	Brg Size	Required
A	4.0"	1.5"
D	3.5"	1.5"

Plus 21 Wind Load Case(s)
Plus 1 UBC LL Load Case(s)
Plus 1 DL Load Case(s)

Membr	CSI	P	Lbs	Axl-CSI-Bnd
-----Top Chords-----				
A -B	0.37	247 C	0.01	0.36
B -C	0.17	232 C	0.02	0.15
-----Bottom Chords-----				

MiTek® Online Plus™ APPROX. TRUSS WEIGHT: 42.0 LBS

A -E	0.25	232 T	0.04	0.21
E -D	0.20	55 T	0.00	0.20
-----Webs-----				
E -B	0.09	294 T		
E -C	0.16	406 T		
D -C	0.10	328 C	WindLd	

TL Defl -0.06" in A -E L/999
LL Defl -0.03" in A -E L/999
Shear // Grain in A -B 0.20

Plates for each ply each face.
Plate - MT20 20 Ga, Gross Area
Plate - MT2H 20 Ga, Gross Area
Plate - MS18 18 Ga, Gross Area
Jt Type Plt Size X Y JSI
A MT20 3.0x 5.0 0.8 0.2 0.61
B MT20 3.0x 6.0 Ctr Ctr 0.91
C MT20 3.0x 4.0 Ctr Ctr 0.77
E MT20 4.0x 5.0 Ctr Ctr 0.20
D MT20 2.0x 4.0 Ctr Ctr 0.22

REVIEWED BY:
MiTek Industries, Inc.
6904 Parke East Blvd.
Tampa, FL 33610

REFER TO ONLINE PLUS GENERAL NOTES AND SYMBOLS SHEET FOR ADDITIONAL SPECIFICATIONS.

NOTES:
Trusses Manufactured by:
RIDGWAY ROOF TRUSS
Analysis Conforms To:
FBC2010
TPI 2007

This truss has been designed for 20.0 psf LL on the B.C. in areas where a rectangle 3- 6- 0 tall by 2- 0- 0 wide will fit between the B.C. and any other member.
Design checked for 10 psf non-concurrent LL on BC.
Wind Loads - ANSI / ASCE 7-10

Truss is designed as Components and Claddings* for Exterior zone location.
Wind Speed: 130 mph
Risk Category : II
Mean Roof Height: 25-0
Exposure Category: B
Building Type: Enclosed
TC Dead Load: 4.0 psf
BC Dead Load: 6.0 psf
Max comp. force 351 Lbs
Max tens. force 406 Lbs
Connector Plate Fabrication Tolerance = 20%
This truss is designed for a creep factor of 1.5 which is used to calculate total load deflection.

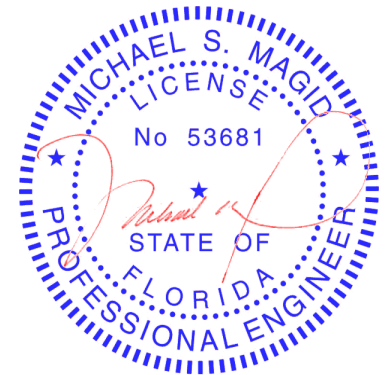

FL Cert. 6634

Job 120440	Mark R34	Quan 10	Type MONO	Span 70600	P1-H1 4	Left OH 0	Right OH 0	Engineering T4462854
----------------------	--------------------	------------	--------------	---------------	------------	--------------	---------------	--------------------------------

18- Rosas- Dreambuilders

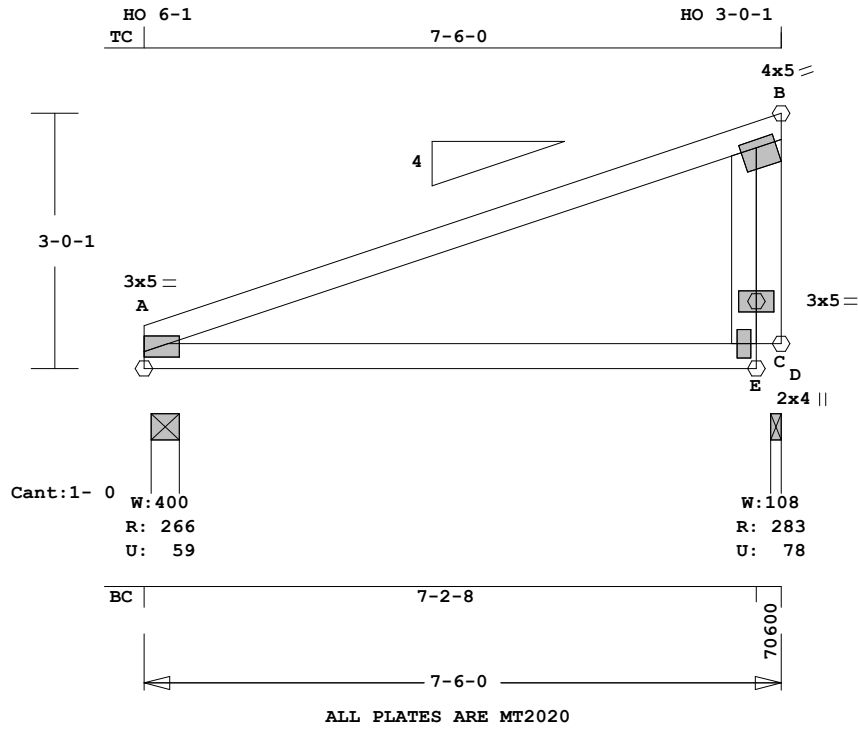

ALL PLATES ARE MT2020

Scale: 0.442" = 1'

MiTek® Online Plus™ APPROX. TRUSS WEIGHT: 37.6 LBS

Online Plus -- Version 30.0.011
RUN DATE: 18-JUL-12

Southern Pine lumber design values are those effective 06-01-12 by SPIB//ALSC UON
CSI -Size- ---Lumber----

TC	0.47	2x 4	SP-#2
BC	0.33	2x 4	SP-#2
WB	0.65	2x 4	SP-#2
BB	---	2x 4	SP-#3

Brace truss as follows:

	O.C.	From	To
TC	Cont.	0- 0- 0	7- 6- 0
or	48.0"	0- 0- 0	7- 6- 0
BC	Cont.	0- 0- 0	7- 6- 0
or	86.5"	0- 0- 0	7- 6- 0

psf-Ld	Dead	Live		
TC	7.0	20.0		
BC	10.0	0.0		
TC+BC	17.0	20.0		
Total	37.0	Spacing 24.0"		
Lumber	Duration Factor	1.25		
Plate	Duration Factor	1.25		
	Fb	Fc	Ft	Emin
TC	1.15	1.10	1.10	1.10
BC	1.10	1.10	1.10	1.10

Total Load Reactions (Lbs)

Jt	Down	Uplift	Horiz-
A	266	59 U	83 R
E	283	79 U	153 R

Jt	Brg Size	Required
A	4.0"	1.5"
E	1.5"	1.5"

Plus 18 Wind Load Case(s)
Plus 1 UBC LL Load Case(s)
Plus 1 DL Load Case(s)

Membr	CSI	P	Lbs	Ax1	CSI-Bnd
-----Top Chords-----					
A	-B	0.47	145 C	0.00	0.47
B	-B	0.01	3 C	0.00	0.01

-----Bottom Chords-----
A -D 0.33 138 T 0.02 0.31
-----Webs-----
D -E 0.43 156 T 0.02 0.41
E -B 0.65 252 T 0.00 0.65

TL Defl -0.11" in A -D L/731
LL Defl -0.05" in A -D L/999
Shear // Grain in A -B 0.25

Plates for each ply each face.
Plate - MT20 20 Ga, Gross Area
Plate - MT2H 20 Ga, Gross Area
Plate - MS18 18 Ga, Gross Area
Jt Type Plt Size X Y JSI
A MT20 3.0x 5.0 0.8 0.2 0.61
B MT20 4.0x 5.0 0.5-0.8 0.15
D MT20 2.0x 4.0 Ctr Ctr 0.13
E MT20 3.0x 5.0 Ctr Ctr 0.00

REVIEWED BY:
MiTek Industries, Inc.
6904 Parke East Blvd.
Tampa, FL 33610

REFER TO ONLINE PLUS GENERAL NOTES AND SYMBOLS SHEET FOR ADDITIONAL SPECIFICATIONS.

NOTES:
Trusses Manufactured by:
RIDGWAY ROOF TRUSS
Analysis Conforms To:
FBC2010
TPI 2007
This truss has been designed for 20.0 psf LL on the B.C. in areas where a rectangle 3- 6- 0 tall by 2- 0- 0 wide will fit between the B.C. and any other member. Design checked for 10 psf non-concurrent LL on BC. Max gap between edge of brg and end vertical or diagonal web is 1/2".

Wind Loads - ANSI / ASCE 7-10
Truss is designed as Components and Claddings* for Exterior zone location.
Wind Speed: 130 mph
Risk Category : II
Mean Roof Height: 25-0
Exposure Category: B
Building Type: Enclosed
TC Dead Load: 4.0 psf
BC Dead Load: 6.0 psf
Max comp. force 181 Lbs
Max tens. force 252 Lbs
Connector Plate Fabrication Tolerance = 20%
This truss is designed for a creep factor of 1.5 which is used to calculate total load deflection.

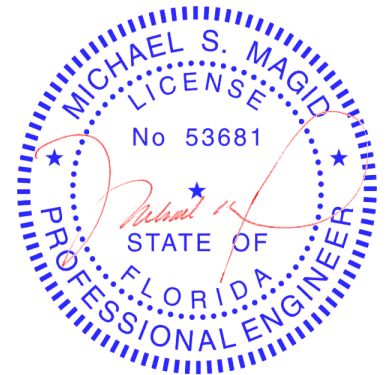

FL Cert. 6634

Job 120440	Mark R35	Quan 1	Type HHIP	Span 70600	P1-H1 4	Left OH 0	Right OH 0	Engineering T4462855
----------------------	--------------------	-----------	--------------	---------------	------------	--------------	---------------	--------------------------------

18- Rosas- Dreambuilders

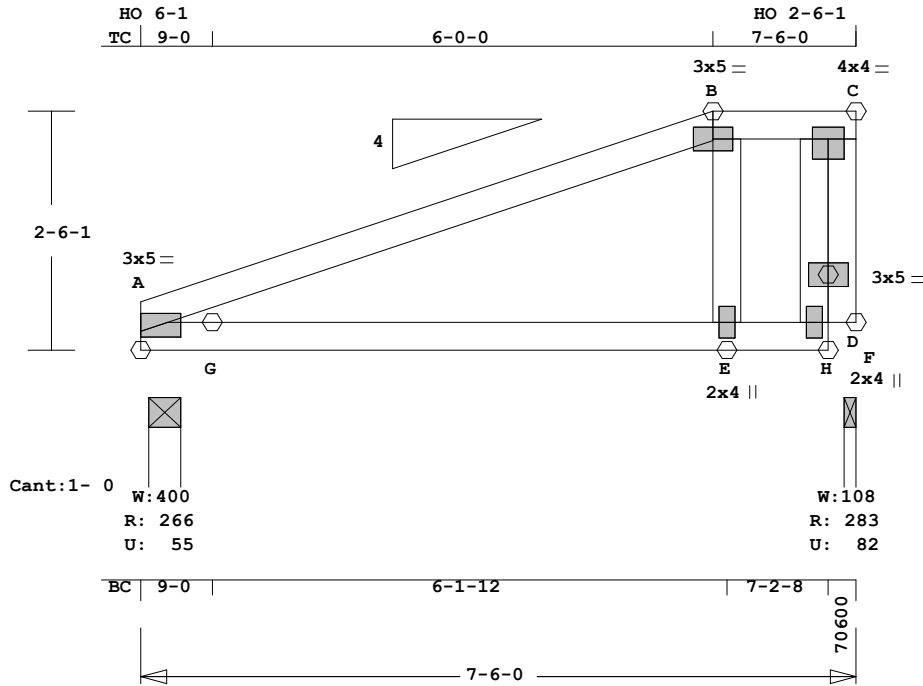

ALL PLATES ARE MT2020

Scale: 0.496" = 1'

MiTek® Online Plus™ APPROX. TRUSS WEIGHT: 39.5 LBS

Online Plus -- Version 30.0.011
RUN DATE: 18-JUL-12

Southern Pine lumber design values are those effective 06-01-12 by SPIB//ALSC UON

CSI	-Size-	Lumber	SP-#
TC	0.37	2x 4	SP-#2
BC	0.25	2x 4	SP-#2
WB	0.63	2x 4	SP-#3
BB	---	2x 4	SP-#3

Brace truss as follows:

O.C.	From	To
TC Cont.	0- 0- 0	7- 6- 0
or	48.0"	0- 0- 0 7- 6- 0
BC Cont.	0- 0- 0	7- 6- 0
or	86.5"	0- 0- 0 7- 6- 0

psf-Ld	Dead	Live
TC	7.0	20.0
BC	10.0	0.0
TC+BC	17.0	20.0
Total	37.0	Spacing 24.0"
Lumber Duration Factor	1.25	
Plate Duration Factor	1.25	
	Fb	Fc Ft Emin
TC	1.15	1.10 1.10 1.10
BC	1.10	1.10 1.10 1.10

Total Load Reactions (Lbs)

Jt	Down	Uplift	Horiz-
A	266	56 U	86 R
H	283	82 U	90 R

Jt	Brg Size	Required
A	4.0"	1.5"
H	1.5"	1.5"

Plus 21 Wind Load Case(s)
Plus 1 UBC LL Load Case(s)
Plus 1 DL Load Case(s)

Membr	CSI	P Lbs	Axl-CSI-Bnd
-----Top Chords-----			
A -B	0.37	187 C	0.00 0.37
B -C	0.18	93 C	0.00 0.18
C -C	0.01	0 T	0.00 0.01

-----Bottom Chords-----

A -E	0.25	173 T	0.03 0.22
E -F	0.19	77 T	0.01 0.18

-----Webs-----

E -B	0.63	169 T	0.00 0.63
F -H	0.50	143 T	0.05 0.45
H -C	0.45	139 C	0.00 0.45

TL Defl -0.07" in A -E L/999
LL Defl -0.03" in A -E L/999
Shear // Grain in A -B 0.20

Plates for each ply each face.

Plate - MT20 20 Ga, Gross Area
Plate - MT2H 20 Ga, Gross Area
Plate - MS18 18 Ga, Gross Area

Jt Type Plt Size X Y JSI

A	MT20	3.0x 5.0	0.8 0.2	0.61
B	MT20	3.0x 5.0	Ctr Ctr	0.77
C	MT20	4.0x 4.0	Ctr-0.5	0.10
E	MT20	2.0x 4.0	Ctr Ctr	0.14
F	MT20	2.0x 4.0	Ctr Ctr	0.12
H	MT20	3.0x 5.0	Ctr Ctr	0.00

REVIEWED BY:
MiTek Industries, Inc.
6904 Parke East Blvd.
Tampa, FL 33610

REFER TO ONLINE PLUS GENERAL NOTES AND SYMBOLS SHEET FOR ADDITIONAL SPECIFICATIONS.

NOTES:
Trusses Manufactured by:
RIDGWAY ROOF TRUSS
Analysis Conforms To:
FBC2010
TPI 2007

This truss has been designed for 20.0 psf LL on the B.C. in areas where a rectangle 3- 6- 0 tall by 2- 0- 0 wide will fit between the B.C. and any other member.
Design checked for 10 psf non-concurrent LL on BC.

Max gap between edge of brg and end vertical or diagonal web is 1/2".
Wind Loads - ANSI / ASCE 7-10
Truss is designed as Components and Claddings* for Exterior zone location.
Wind Speed: 130 mph
Risk Category : II
Mean Roof Height: 25-0
Exposure Category: B
Building Type: Enclosed
TC Dead Load: 4.0 psf
BC Dead Load: 6.0 psf
Max comp. force 187 Lbs
Max tens. force 173 Lbs
Connector Plate Fabrication Tolerance = 20%
This truss is designed for a creep factor of 1.5 which is used to calculate total load deflection.

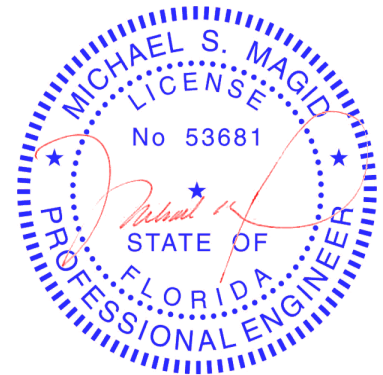

FL Cert. 6634

July 18, 2012

Job 120440	Mark R36	Quan 1	Type SP	Span 70600	P1-H1 4	Left OH 0	Right OH 0	Engineering T4462856
----------------------	--------------------	-----------	------------	---------------	------------	--------------	---------------	--------------------------------

18- Rosas- Dreambuilders

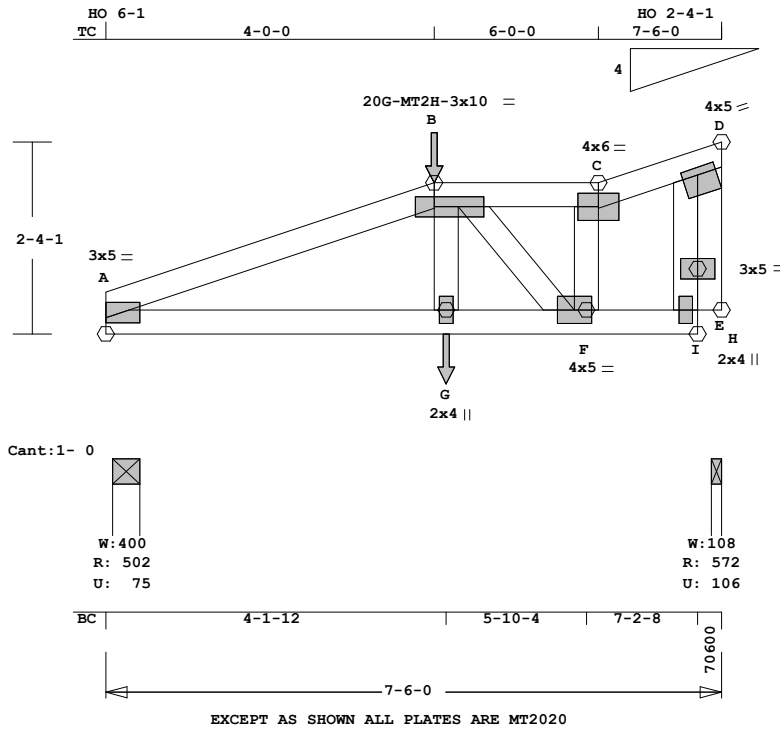

Scale: 0.428" = 1'

Online Plus -- Version 30.0.011
RUN DATE: 18-JUL-12

Southern Pine lumber design values are those effective 06-01-12 by SPIB//ALSC UON
CSI -Size- ---Lumber---
TC 0.33 2x 4 SP-#2
BC 0.74 2x 4 SP-#1
WB 0.29 2x 4 SP-#3
BB --- 2x 4 SP-#3

Brace truss as follows:
O.C. From To
TC Cont. 0-0-0 7-6-0
or 48.0" 0-0-0 7-6-0
BC Cont. 0-0-0 7-6-0
or 86.5" 0-0-0 7-6-0

psf-Ld	Dead	Live
TC	7.0	20.0
BC	10.0	0.0
TC+BC	17.0	20.0
Total	37.0	Spacing 24.0"
Lumber Duration Factor	1.25	
Plate Duration Factor	1.25	
	Fb	Fc Ft Emin
TC	1.00	1.00 1.00 1.00
BC	1.00	1.00 1.00 1.00

Total Load Reactions (Lbs)
Jt Down Uplift Horiz-
A 502 75 U 60 R
I 572 106 U 30 R

Jt	Brg Size	Required
A	4.0"	1.5"
I	1.5"	1.5"

LC# 1 Standard Loading
Dur Fctrs - Lbr 1.25 Plt 1.25
plf - Dead Live* From To
TC V 14 40 0.0' 7.5'
BC V 20 0 0.0' 7.5'
TC V 163 109 4.0' CL-LB
TC V 40 60 4.0' CL-LB
BC V 92 61 4.1' CL-LB

Plus 21 Wind Load Case(s)
Plus 1 UBC LL Load Case(s)
Plus 1 DL Load Case(s)

Membr CSI P Lbs Axl-CSI-Bnd
-----Top Chords-----
A -B 0.33 940 C 0.10 0.23

MiTek® Online Plus™ APPROX. TRUSS WEIGHT: 43.4 LBS

B -C	0.29	35 C	0.00	0.29
C -D	0.24	40 C	0.00	0.24
D -D	0.01	3 C	0.00	0.01

-----Bottom Chords-----
A -G 0.23 882 T 0.12 0.11
G -F 0.74 826 T 0.11 0.63
F -H 0.61 29 T 0.00 0.61

-----Webs-----
G -B 0.18 489 T
B -F 0.29 1117 C
F -C 0.04 142 T
H -I 0.16 402 T 0.11 0.05
I -D 0.12 169 C 0.05 0.07

TL Defl -0.16" in G -F L/532
LL Defl -0.06" in G -F L/999
Shear // Grain in F -H 0.52

Plates for each ply each face.
Plate - MT20 20 Ga, Gross Area
Plate - MT2H 20 Ga, Gross Area
Plate - MS18 18 Ga, Gross Area
Jt Type Plt Size X Y JSI
A MT20 3.0x 5.0 0.8 0.2 0.61
B MT2H 3.0x10.0 0.5 Ctr 0.77
C MT20 4.0x 6.0 Ctr Ctr 0.97
D MT20 4.0x 5.0 0.5-0.8 0.10
G MT20 2.0x 4.0 Ctr Ctr 0.44
F MT20 4.0x 5.0 Ctr Ctr 0.58
H MT20 2.0x 4.0 Ctr Ctr 0.37
I MT20 3.0x 5.0 Ctr Ctr 0.00

REVIEWED BY:
MiTek Industries, Inc.
6904 Parke East Blvd.
Tampa, FL 33610

REFER TO ONLINE PLUS GENERAL NOTES AND SYMBOLS SHEET FOR ADDITIONAL SPECIFICATIONS.

NOTES:
Trusses Manufactured by:
RIDGWAY ROOF TRUSS
Analysis Conforms To:
FBC2010
TPI 2007

This truss has been designed for 20.0 psf LL on the B.C. in areas where a rectangle 3-6-0 tall by 2-0-0 wide will fit between the B.C. and any other member.
Design checked for 10 psf non-

concurrent LL on BC.
Max gap between edge of brg and end vertical or diagonal web is 1/2".
Wind Loads - ANSI / ASCE 7-10
Truss is designed as Components and Claddings* for Exterior zone location.
Wind Speed: 130 mph
Risk Category : II
Mean Roof Height: 25-0
Exposure Category: B
Building Type: Enclosed
TC Dead Load: 4.0 psf
BC Dead Load: 6.0 psf
Max comp. force 1117 Lbs
Max tens. force 882 Lbs
Connector Plate Fabrication Tolerance = 20%
This truss is designed for a creep factor of 1.5 which is used to calculate total load deflection.

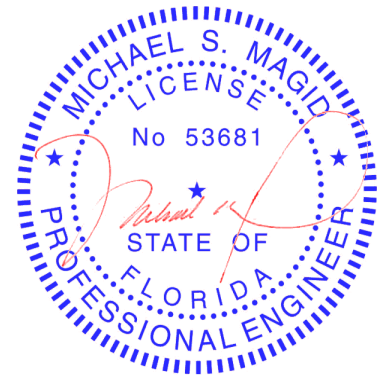

FL Cert. 6634

Job 120440	Mark R37	Quan 1	Type SP	Span 40000	Pl-H1 4	Left OH 0	Right OH 0	Engineering T4462857
----------------------	--------------------	-----------	------------	---------------	------------	--------------	---------------	--------------------------------

18- Rosas- Dreambuilders

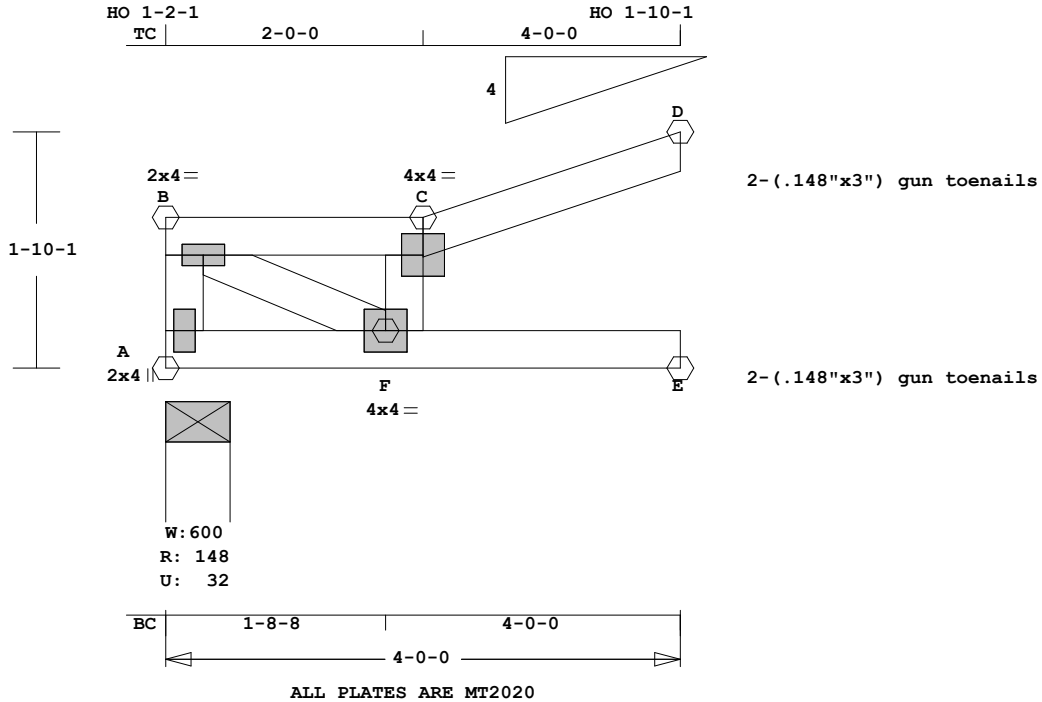

Scale: 0.670" = 1'

MiTek® Online Plus™ APPROX. TRUSS WEIGHT: 20.6 LBS

Online Plus -- Version 30.0.011
RUN DATE: 18-JUL-12

Southern Pine lumber design values are those effective 06-01-12 by SPIB//ALSC UON
CSI -Size- ---Lumber---
TC 0.13 2x 4 SP-#2
BC 0.15 2x 4 SP-#2
WB 0.03 2x 4 SP-#3

Brace truss as follows:

O.C.	From	To
TC Cont.	0- 0- 0	3- 8- 8
or	48.0"	0- 0- 0 3- 8- 8
BC Cont.	0- 0- 0	3- 8- 8
or	48.0"	0- 0- 0 3- 8- 8

psf-Ld	Dead	Live
TC	7.0	20.0
BC	10.0	0.0
TC+BC	17.0	20.0
Total	37.0	Spacing 24.0"
Lumber Duration Factor	1.25	
Plate Duration Factor	1.25	
	Fb	Fc Ft Emin
TC	1.15	1.10 1.10 1.10
BC	1.10	1.10 1.10 1.10

Total Load Reactions (Lbs)

Jt	Down	Uplift	Horiz-
A	149	32 U	42 R
E	66	1 U	
D	90	44 U	26 R

Jt	Brg Size	Required
A	6.0"	1.5"
E	3.5"	1.5"
D	1.5"	1.5"

Plus 21 Wind Load Case(s)
Plus 1 UBC LL Load Case(s)
Plus 1 DL Load Case(s)

Membr	CSI	P Lbs	Axl	CSI-Bnd
-----Top Chords-----				
B -C	0.13	78 C	0.00	0.13
C -D	0.13	46 C	0.00	0.13
-----Bottom Chords-----				
A -F	0.15	77 C	0.00	0.15

F -E 0.15 0 T 0.00 0.15
-----Webs-----
A -B 0.02 87 C WindLd
B -F 0.03 103 T
F -C 0.02 90 T WindLd
TL Defl -0.03" in A -F L/999
LL Defl -0.01" in A -F L/999
Hz Disp LL DL TL
Jt D 0.01" 0.00" 0.00"
Shear // Grain in C -D 0.12

Plates for each ply each face.
Plate - MT20 20 Ga, Gross Area
Plate - MT2H 20 Ga, Gross Area
Plate - MS18 18 Ga, Gross Area
Jt Type Plt Size X Y JSI
B MT20 2.0x 4.0 Ctr Ctr 0.25
C MT20 4.0x 4.0 Ctr Ctr 0.58
A MT20 2.0x 4.0 Ctr Ctr 0.12
F MT20 4.0x 4.0 Ctr Ctr 0.13

REVIEWED BY:
MiTek Industries, Inc.
6904 Parke East Blvd.
Tampa, FL 33610

REFER TO ONLINE PLUS GENERAL NOTES AND SYMBOLS SHEET FOR ADDITIONAL SPECIFICATIONS.

For proper installation of toe-nails, refer to the 2005 National Design Specification (NDS) for Wood Construction

NOTES:
Trusses Manufactured by:
RIDGWAY ROOF TRUSS
Analysis Conforms To:

FBC2010
TPI 2007
This truss has been designed for 20.0 psf LL on the B.C. in areas where a rectangle 3- 6- 0 tall by 2- 0- 0 wide will fit between the B.C. and any other member.
Design checked for 10 psf non-

concurrent LL on BC.
Wind Loads - ANSI / ASCE 7-10
Truss is designed as Components and Claddings* for Exterior zone location.
Wind Speed: 130 mph
Risk Category : II
Mean Roof Height: 25-0
Exposure Category: B
Building Type: Enclosed
TC Dead Load: 4.0 psf
BC Dead Load: 6.0 psf
Max comp. force 87 Lbs
Max tens. force 103 Lbs
Connector Plate Fabrication Tolerance = 20%
This truss is designed for a creep factor of 1.5 which is used to calculate total load deflection.

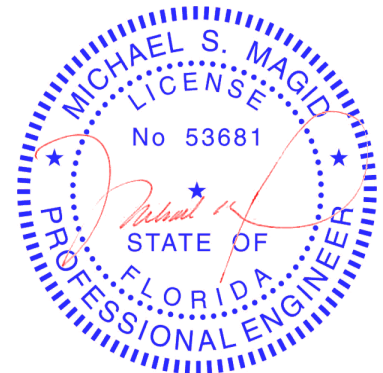

FL Cert. 6634

Job 120440	Mark R38	Quan 1	Type HIPP	Span 330000	Pl-H1 9	Left OH 0	Right OH 0	Engineering T4462858
----------------------	--------------------	-----------	--------------	----------------	------------	--------------	---------------	--------------------------------

18- Rosas- Dreambuilders

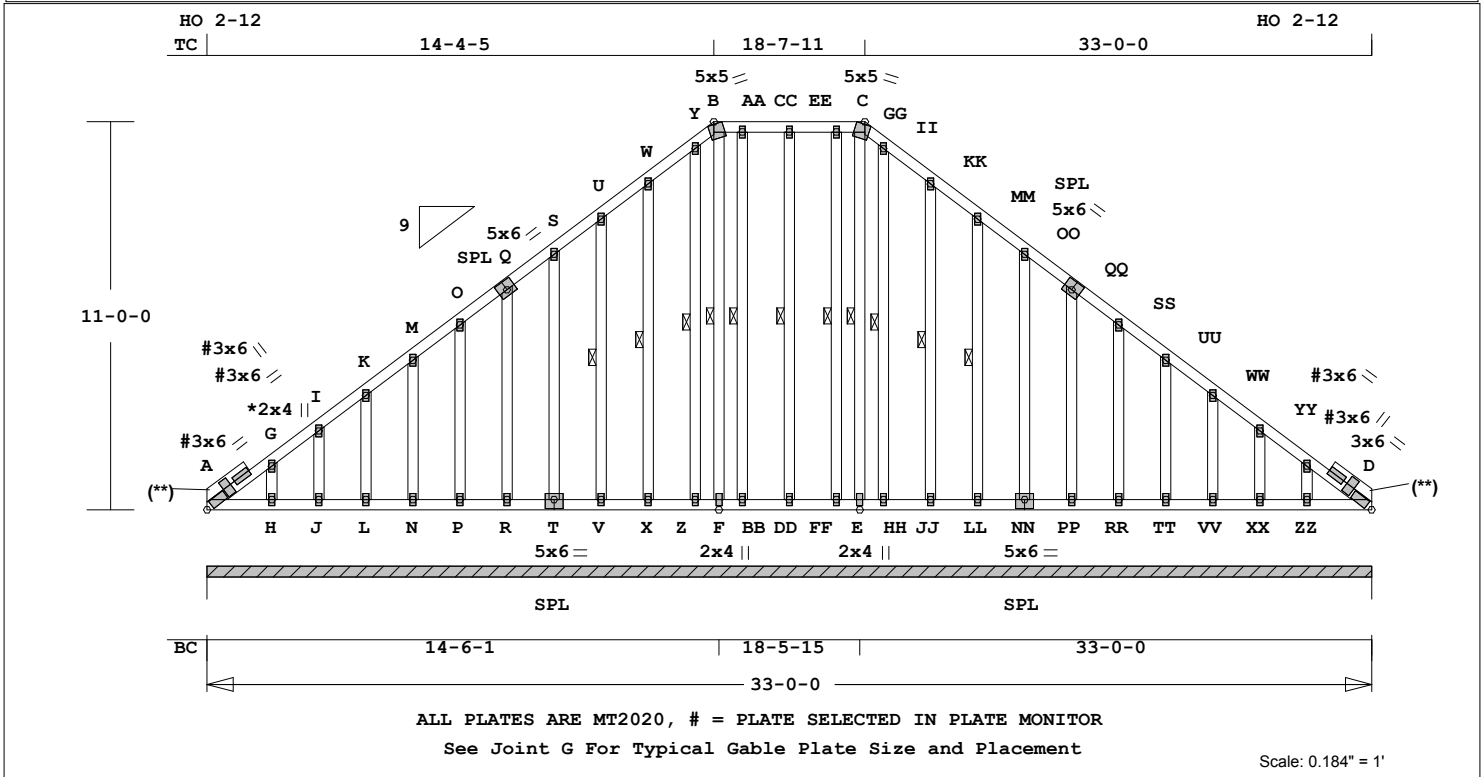

Online Plus -- Version 30.0.011
 RUN DATE: 18-JUL-12

Southern Pine lumber design values are those effective 06-01-12 by SPIB//ALSC UON
 CSI -Size- ---Lumber---
 TC 0.05 2x 4 SP-#2 (**)
 BC 0.02 2x 4 SP-#2
 WB 0.15 2x 4 SP-#3
 GW 0.22 2x 4 SP-#3

Brace truss as follows:
 O.C. From To
 TC Cont. 0-0-0 33-0-0
 or 48.0" 0-0-0 33-0-0
 BC Cont. 0-0-0 33-0-0
 or 72.0" 0-0-0 33-0-0
 Continuous Lateral Restraint req'd at mid-point of webs:
 F-B E-C V-U X-W
 Z-Y BB-AA DD-CC FF-EE
 HH-GG JJ-II LL-KK
 Attach CLR with (2)-10d nails at each web.
 Refer to BCSI for diagonal restraint requirements.

psf-Ld	Dead	Live
TC	7.0	20.0
BC	10.0	0.0
TC+BC	17.0	20.0
Total	37.0	Spacing 24.0"
Lumber Duration Factor	1.25	
Plate Duration Factor	1.25	
Fb	Fc	Ft
TC	1.15	1.10
BC	1.10	1.10

Total Load Reactions (Lbs)
 Jt Down Uplift Horiz-
 A 2430 582 U 229 R

Jt Brg Size Required
 A 396.0" 0"-to- 396"

Plus 21 Wind Load Case(s)
 Plus 1 UBC LL Load Case(s)
 Plus 1 DL Load Case(s)

Membr	CSI	P	Lbs	Axl	CSI-Bnd
-----Top Chords-----					
A-G	0.05	261	C	0.03	0.02
G-I	0.04	206	C	0.02	0.02
I-K	0.03	161	C	0.02	0.01
K-M	0.02	113	C	0.01	0.01
M-O	0.02	82	C	0.01	0.01
O-Q	0.01	69	C	0.00	0.01
Q-S	0.01	57	C	0.00	0.01
S-U	0.02	76	T	0.01	0.01
U-W	0.03	124	T	0.02	0.01
W-Y	0.03	174	T	0.02	0.01
Y-B	0.04	183	T	0.03	0.01
B-AA	0.03	172	T	0.02	0.01
AA-CC	0.03	172	T	0.02	0.01

MiTek® Online Plus™ APPROX. TRUSS WEIGHT: 451.8 LBS					
CC-EE	0.03	172	T	0.02	0.01
EE-C	0.03	172	T	0.02	0.01
C-GG	0.04	183	T	0.03	0.01
GG-II	0.03	174	T	0.02	0.01
II-KK	0.03	124	T	0.02	0.01
KK-MM	0.02	76	T	0.01	0.01
MM-OO	0.01	57	C	0.00	0.01
OO-QQ	0.01	69	C	0.00	0.01
QQ-SS	0.02	82	C	0.01	0.01
SS-UU	0.02	113	C	0.01	0.01
UU-VV	0.03	161	C	0.02	0.01
VV-WW	0.04	206	C	0.02	0.02
WW-YY	0.03	261	C	0.03	0.02
YY-D	0.05	261	C	0.03	0.02
-----Bottom Chords-----					
A-H	0.02	31	C	0.00	0.02
H-J	0.01	0	T	0.00	0.01
J-L	0.01	0	T	0.00	0.01
L-N	0.01	0	T	0.00	0.01
N-P	0.01	0	T	0.00	0.01
P-R	0.01	0	T	0.00	0.01
R-T	0.01	0	T	0.00	0.01
T-V	0.01	0	T	0.00	0.01
V-X	0.01	0	T	0.00	0.01
X-Z	0.01	0	T	0.00	0.01
Z-F	0.00	0	T	0.00	0.00
F-BB	0.00	0	T	0.00	0.00
BB-DD	0.01	0	T	0.00	0.01
DD-FF	0.01	0	T	0.00	0.01
FF-E	0.00	0	T	0.00	0.00
E-HH	0.00	0	T	0.00	0.00
HH-JJ	0.01	0	T	0.00	0.01
JJ-LL	0.01	0	T	0.00	0.01
LL-NN	0.01	0	T	0.00	0.01
NN-PP	0.01	0	T	0.00	0.01
PP-RR	0.01	0	T	0.00	0.01
RR-TT	0.01	0	T	0.00	0.01
TT-VV	0.01	0	T	0.00	0.01
VV-XX	0.01	0	T	0.00	0.01
XX-ZZ	0.01	0	T	0.00	0.01
ZZ-D	0.02	31	C	0.00	0.02
-----Webs-----					
F-B	0.15	50	C	1	Br
E-C	0.15	50	C	1	Br
-----Gable Webs-----					
H-G	0.02	100	C		
J-I	0.02	78	C		
L-K	0.02	82	C		
N-M	0.04	81	C		
P-O	0.06	81	C		
R-Q	0.08	81	C		
T-S	0.11	81	C		
V-U	0.15	83	C		1 Br
X-W	0.19	86	C		1 Br
Z-Y	0.14	51	C		1 Br
BB-AA	0.15	51	C		1 Br
DD-CC	0.22	75	C		1 Br
FF-EE	0.15	51	C		1 Br
HH-GG	0.14	51	C		1 Br
JJ-II	0.19	86	C		1 Br
LL-KK	0.15	83	C		1 Br
NN-MM	0.11	81	C		
PP-OO	0.08	81	C		
RR-QQ	0.06	81	C		
TT-SS	0.04	81	C		
VV-UU	0.02	82	C		

= Plate Monitor used
 REVIEWED BY:
 MiTek Industries, Inc.
 6904 Parke East Blvd.
 Tampa, FL 33610

REFER TO ONLINE PLUS GENERAL NOTES AND SYMBOLS SHEET FOR ADDITIONAL SPECIFICATIONS.

NOTES:
 Trusses Manufactured by:
 RIDGWAY ROOF TRUSS
 Analysis Conforms To:
 FBC2010
 TPI 2007
 Design checked for 10 psf non-concurrent LL on BC.
 Truss designed for wind loads in the plane of the truss only. For studs exposed to wind (normal to the face), see Standard Industry Gable End Details as applicable, or consult qualified Building Designer as per ANSI/TPI 1.

NOTE: USER MODIFIED PLATES
 This design may have plates selected through a plate monitor.
 Wind Loads - ANSI / ASCE 7-10

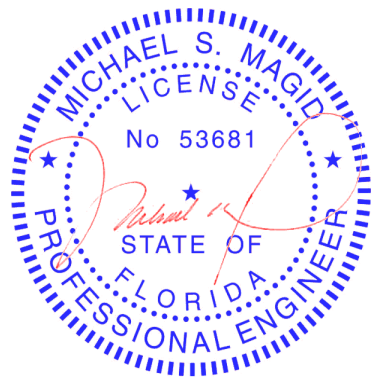

FL Cert. 6634

July 18, 2012

Job	Mark	Quan	Type	Span	Pl-H1	Left OH	Right OH	Engineering
120440	R38	1	HIPP	330000	9	0	0	T4462858
18- Rosas- Dreambuilders								

Truss is designed as
 Components and Claddings*
 for Exterior zone location.
 Wind Speed: 130 mph
 Risk Category : II
 Mean Roof Height: 25-0
 Exposure Category: B
 Building Type: Enclosed
 TC Dead Load: 4.0 psf
 BC Dead Load: 6.0 psf
 Max comp. force 261 Lbs
 Max tens. force 208 Lbs
 Connector Plate Fabrication
 Tolerance = 20%
 This truss is designed for a
 creep factor of 1.5 which
 is used to calculate total
 load deflection.

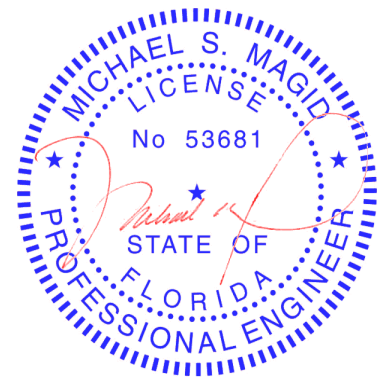

FL Cert. 6634

July 18, 2012

Job 120440	Mark R39	Quan 5	Type HIPP	Span 330000	Pl-H1 9	Left OH 0	Right OH 0	Engineering T4462859
----------------------	--------------------	-----------	--------------	----------------	------------	--------------	---------------	--------------------------------

18- Rosas- Dreambuilders

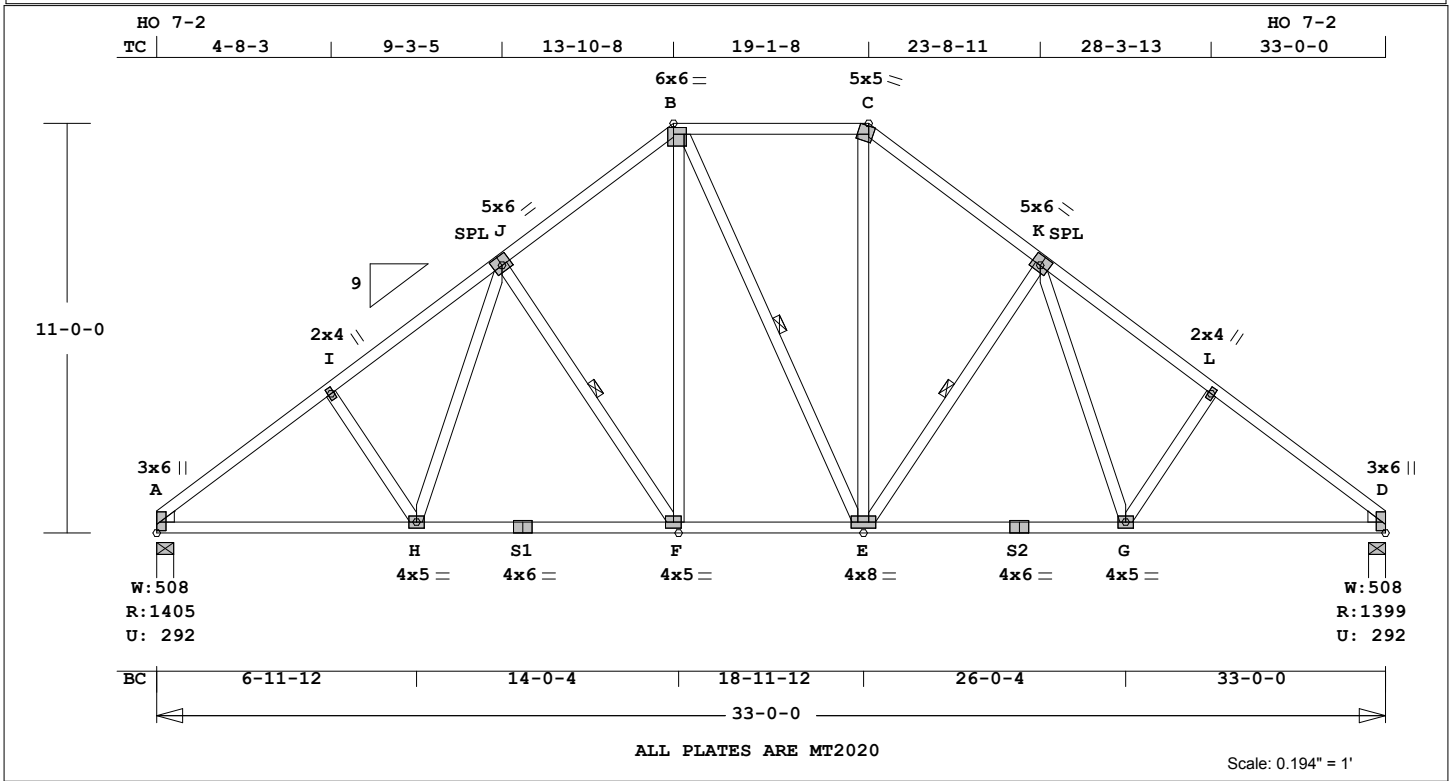

Online Plus -- Version 30.0.011
RUN DATE: 18-JUL-12

Southern Pine lumber design values are those effective 06-01-12 by SP18//ALSC UON

CSI	Size	Lumber
TC	0.62 2x 4	SP-#2
BC	0.74 2x 4	SP-#2
WB	0.29 2x 4	SP-#3
WG	--- 2x 4	SP-#3

Brace truss as follows:
O.C. From To
TC Cont. 0-0-0 33-0-0
or 42.0" 0-0-0 33-0-0
BC Cont. 0-0-0 33-0-0
or 120.0" 0-0-0 33-0-0

Continuous Lateral Restraint req'd at mid-point of webs:
J -F B -E E -K
Attach CLR with (2)-10d nails at each web.
Refer to BCSI for diagonal restraint requirements.

psf-Ld	Dead	Live
TC	7.0	20.0
BC	10.0	0.0
TC+BC	17.0	20.0
Total	37.0	Spacing 24.0"
Lumber	Duration Factor	1.25
Plate	Duration Factor	1.25
	Fb	Fc Ft Emin
TC	1.15	1.10 1.10 1.10
BC	1.10	1.10 1.10 1.10

Total Load Reactions (Lbs)	Jt	Down	Uplift	Horiz-
A	1405	292	U	224 R
D	1399	292	U	224 R

Jt	Brg Size	Required
A	5.5"	1.7"
D	5.5"	1.7"

Plus 21 Wind Load Case(s)
Plus 1 UBC LL Load Case(s)
Plus 1 BC LL Load Case(s)
Plus 1 DL Load Case(s)

Membr	CSI	P	Lbs	Ax1	CSI-Bnd
-----Top Chords-----					
A -I	0.62	1895	C	0.05	0.57
I -J	0.34	1760	C	0.06	0.28
J -B	0.26	1390	C	0.02	0.24
B -C	0.35	1105	C	0.02	0.33
C -K	0.23	1381	C	0.03	0.20
K -L	0.30	1750	C	0.06	0.24

MiTek® Online Plus™ APPROX. TRUSS WEIGHT: 275.5 LBS

L -D	0.61	1885	C	0.05	0.56
-----Bottom Chords-----					
A -H	0.74	1485	T	0.31	0.43
H -S1	0.74	1326	T	0.28	0.46
S1 -F	0.74	1326	T	0.28	0.46
F -E	0.54	1109	T	0.23	0.31
E -S2	0.74	1319	T	0.28	0.46
S2 -G	0.74	1319	T	0.28	0.46
G -D	0.73	1477	T	0.31	0.42
-----Webs-----					
I -H	0.08	188	C		
H -J	0.12	315	T		
J -F	0.17	410	C		1 Br
F -B	0.29	578	T		
B -E	0.08	117	T		1 Br
E -C	0.29	552	T		
E -K	0.17	413	C		1 Br
K -G	0.12	313	T		
G -L	0.08	187	C		

TL Defl	-0.39"	in H -F	L/998
LL Defl	-0.21"	in H -F	L/999
Shear // Grain	in A -I	0.18	

Jt	Type	Plt Size	X	Y	JSI
A	MT20	3.0x 6.0	1.0	0.6	0.79
I	MT20	2.0x 4.0	Ctr	Ctr	0.30
J	MT20	5.0x 6.0	0.4	0.5	0.48
B	MT20	6.0x 6.0	0.5	0.8	0.67
C	MT20	5.0x 5.0	1.1	3.2	0.77
K	MT20	5.0x 6.0	0.4	0.5	0.49
L	MT20	2.0x 4.0	Ctr	Ctr	0.30
D	MT20	3.0x 6.0	1.0	0.6	0.79
H	MT20	4.0x 5.0	Ctr	Ctr	0.27
S1	MT20	4.0x 6.0	Ctr	0.2	0.62
F	MT20	4.0x 5.0	Ctr	Ctr	0.33
E	MT20	4.0x 8.0	Ctr	Ctr	0.26
S2	MT20	4.0x 6.0	Ctr	0.2	0.62
G	MT20	4.0x 5.0	Ctr	Ctr	0.27

REVIEWED BY:
MiTek Industries, Inc.
6904 Parke East Blvd.
Tampa, FL 33610

REFER TO ONLINE PLUS GENERAL NOTES AND SYMBOLS SHEET FOR ADDITIONAL SPECIFICATIONS.

NOTES:
Trusses Manufactured by:
RIDGWAY ROOF TRUSS
Analysis Conforms To:
FBC2010
TPI 2007

This truss has been designed for 20.0 psf LL on the B.C. in areas where a rectangle 3- 6- 0 tall by 2- 0- 0 wide will fit between the B.C. and any other member.
Design checked for 10 psf non-concurrent LL on BC.
Wind Loads - ANSI / ASCE 7-10
Truss is designed as Components and Claddings* for Exterior zone location.
Wind Speed: 130 mph
Risk Category: II
Mean Roof Height: 25-0
Exposure Category: B
Building Type: Enclosed
TC Dead Load: 4.0 psf
BC Dead Load: 6.0 psf
Max comp. force 1895 Lbs
Max tens. force 1485 Lbs
Connector Plate Fabrication Tolerance = 20%
This truss is designed for a creep factor of 1.5 which is used to calculate total load deflection.

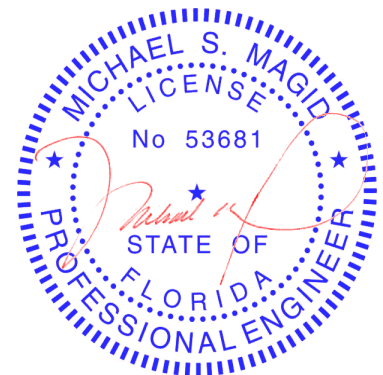

FL Cert. 6634

July 18, 2012

Job 120440	Mark R40	Quan 3	Type HIPP	Span 320900	Pl-H1 9	Left OH 0	Right OH 0	Engineering T4462860
----------------------	--------------------	-----------	--------------	----------------	------------	--------------	---------------	--------------------------------

18- Rosas- Dreambuilders

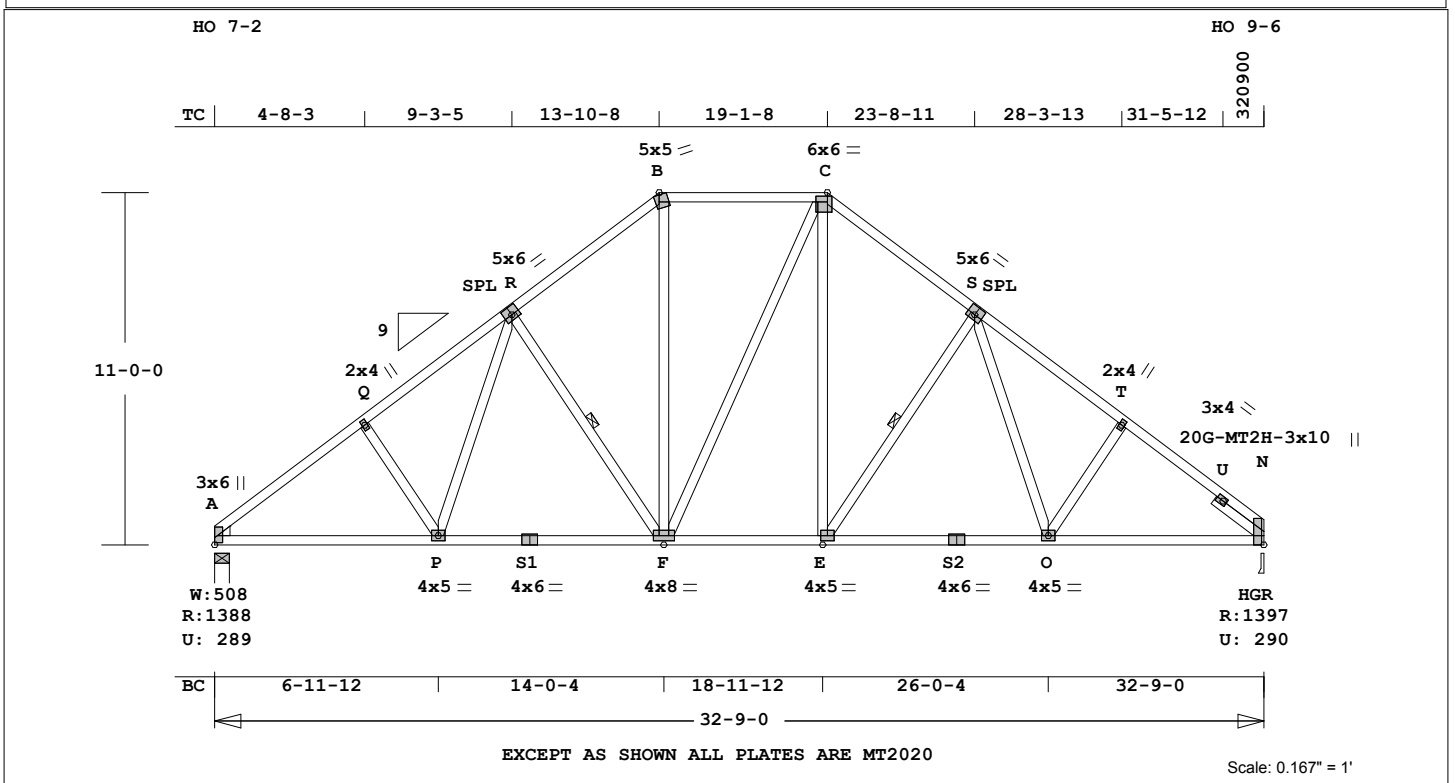

Online Plus -- Version 30.0.011
RUN DATE: 18-JUL-12

Southern Pine lumber design values are those effective
06-01-12 by SPIB//ALSC UON
CSI -Size- ---Lumber---
TC 0.65 2x 4 SP-#2
BC 0.75 2x 4 SP-#2
WB 0.30 2x 4 SP-#3
SL 0.34 2x 4 SP-#3
WG --- 2x 4 SP-#3

Brace truss as follows:
O.C. From To
TC Cont. 0- 0- 0 32- 9- 0
or 42.0" 0- 0- 0 32- 9- 0
BC Cont. 0- 0- 0 32- 9- 0
or 120.0" 0- 0- 0 32- 9- 0
Continuous Lateral Restraint req'd at mid-point of webs:
R -F E -S
Attach CLR with (2)-10d nails at each web.
Refer to BCSI for diagonal restraint requirements.

psf-Ld	Dead	Live
TC	7.0	20.0
BC	10.0	0.0
TC+BC	17.0	20.0
Total	37.0	Spacing 24.0"
Lumber	Duration Factor 1.25	
Plate	Duration Factor 1.25	
	Fb Fc Ft Emin	
TC	1.15 1.10 1.10 1.10	
BC	1.10 1.10 1.10 1.10	

Total Load Reactions (Lbs)			
Jt	Down	Uplift	Horiz-
A	1389	290	222 R
N	1398	290	221 R
Jt	Brg Size	Required	
A	5.5"	1.6"	
N	3.5"	1.6"	

Plus 21 Wind Load Case(s)
Plus 1 UBC LL Load Case(s)
Plus 1 BC LL Load Case(s)
Plus 1 DL Load Case(s)

Membr	CSI	P	Lbs	Ax1	CSI-Bnd
-----Top Chords-----					
A -Q	0.61	1869	C	0.05	0.56
Q -R	0.30	1734	C	0.06	0.24
R -B	0.23	1364	C	0.03	0.20
B -C	0.35	1091	C	0.02	0.33
C -S	0.25	1369	C	0.02	0.23
S -T	0.42	1683	C	0.06	0.36
T -U	0.65	1805	C	0.05	0.60

MiTek® Online Plus™ APPROX. TRUSS WEIGHT: 277.3 LBS

U -N	0.60	594	C	0.00	0.60
-----Bottom Chords-----					
A -P	0.73	1464	T	0.31	0.42
P -S1	0.73	1305	T	0.27	0.46
S1 -F	0.73	1305	T	0.27	0.46
F -E	0.54	1091	T	0.23	0.31
E -S2	0.73	1292	T	0.27	0.46
S2 -O	0.73	1292	T	0.27	0.46
O -N	0.75	1389	T	0.29	0.46
-----Webs-----					
Q -P	0.08	187	C		
P -R	0.12	314	T		
R -F	0.17	414	C		1 Br
F -B	0.29	542	T		
F -C	0.30	121	T		
E -C	0.28	558	T		
E -S	0.16	391	C		1 Br
S -O	0.09	257	T		
O -T	0.05	154	T		
-----Sliders-----					
U -N	0.34	1337	C		
TL Defl	-0.39"	in E -O		L/977	
LL Defl	-0.21"	in E -O		L/999	
Shear // Grain	in U -N		0.31		

Plates for each ply each face.
Plate - MT20 20 Ga, Gross Area
Plate - MT2H 20 Ga, Gross Area
Plate - MS18 18 Ga, Gross Area
Jt Type Plt Size X Y JSI
A MT20 3.0x 6.0 1.0 0.6 0.78
Q MT20 2.0x 4.0 Ctr Ctr 0.30
R MT20 5.0x 6.0-0.4 0.5 0.49
B MT20 5.0x 5.0 1.1-3.2 0.77
C MT20 6.0x 6.0 0.5-0.8 0.66
S MT20 5.0x 6.0 0.4 0.5 0.50
T MT20 2.0x 4.0 Ctr Ctr 0.31
U MT20 3.0x 4.0 Ctr Ctr 0.56
N MT2H 3.0x10.0-2.3 0.7 0.70
P MT20 4.0x 5.0 Ctr Ctr 0.27
S1 MT20 4.0x 6.0 Ctr 0.2 0.61
F MT20 4.0x 8.0 Ctr Ctr 0.26
E MT20 4.0x 5.0 Ctr Ctr 0.32
S2 MT20 4.0x 6.0 Ctr 0.2 0.62
O MT20 4.0x 5.0 Ctr Ctr 0.27

REVIEWED BY:
MiTek Industries, Inc.
6904 Parke East Blvd.
Tampa, FL 33610

REFER TO ONLINE PLUS GENERAL NOTES AND SYMBOLS SHEET FOR ADDITIONAL SPECIFICATIONS.

NOTES:
Trusses Manufactured by:
RIDGWAY ROOF TRUSS
Analysis Conforms To:
FBC2010

TPI 2007
This truss has been designed for 20.0 psf LL on the B.C. in areas where a rectangle 3- 6- 0 tall by 2- 0- 0 wide will fit between the B.C. and any other member.
Design checked for 10 psf non-concurrent LL on BC.
Wind Loads - ANSI / ASCE 7-10
Truss is designed as
Components and Claddings* for Exterior zone location.
Wind Speed: 130 mph
Risk Category : II
Mean Roof Height: 25-0
Exposure Category: B
Building Type: Enclosed
TC Dead Load: 4.0 psf
BC Dead Load: 6.0 psf
Max comp. force 1869 Lbs
Max tens. force 1464 Lbs
Connector Plate Fabrication Tolerance = 20%
This truss is designed for a creep factor of 1.5 which is used to calculate total load deflection.

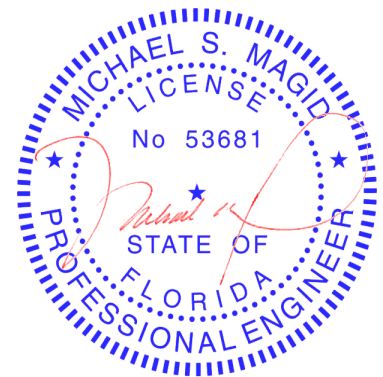

FL Cert. 6634

Job 120440	Mark R41	Quan 8	Type HIPP	Span 320900	Pl-H1 9	Left OH 0	Right OH 0	Engineering T4462861
----------------------	--------------------	-----------	--------------	----------------	------------	--------------	---------------	--------------------------------

18- Rosas- Dreambuilders

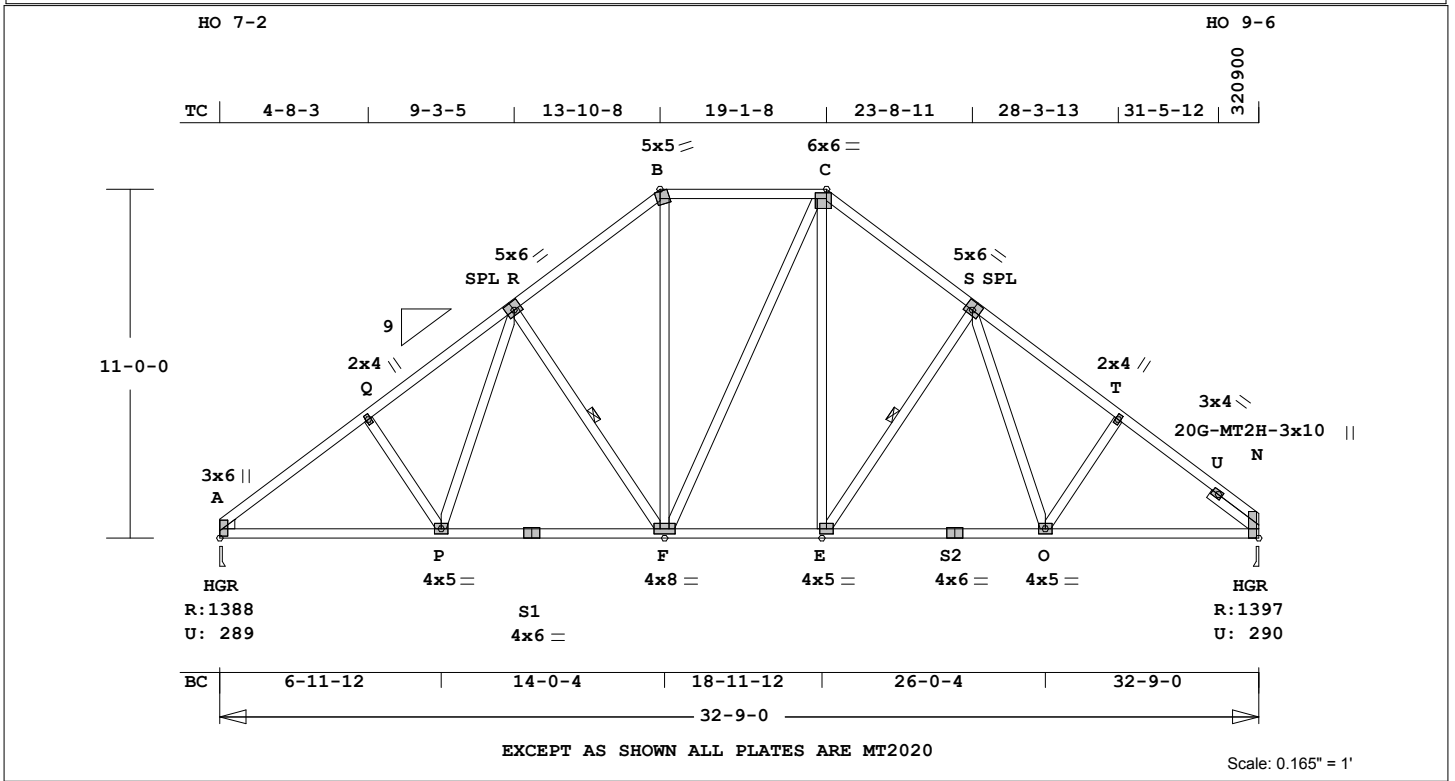

Online Plus -- Version 30.0.011
RUN DATE: 18-JUL-12

Southern Pine lumber design values are those effective
06-01-12 by SPIB//ALSC UON
CSI -Size- ---Lumber---
TC 0.65 2x 4 SP-#2
BC 0.75 2x 4 SP-#2
WB 0.30 2x 4 SP-#3
SL 0.34 2x 4 SP-#3
WG --- 2x 4 SP-#3

Brace truss as follows:
O.C. From To
TC Cont. 0- 0- 0 32- 9- 0
or 42.0" 0- 0- 0 32- 9- 0
BC Cont. 0- 0- 0 32- 9- 0
or 120.0" 0- 0- 0 32- 9- 0
Continuous Lateral Restraint req'd at mid-point of webs:
R -F E -S
Attach CLR with (2)-10d nails at each web.
Refer to BCSI for diagonal restraint requirements.

psf-Ld	Dead	Live
TC	7.0	20.0
BC	10.0	0.0
TC+BC	17.0	20.0
Total	37.0	Spacing 24.0"
Lumber	Duration Factor	1.25
Plate	Duration Factor	1.25
	Fb Fc Ft Emin	
TC	1.15 1.10 1.10 1.10	
BC	1.10 1.10 1.10 1.10	

Total Load Reactions (Lbs)			
Jt	Down	Uplift	Horiz-
A	1389	290	222
N	1398	290	221
Jt	Brg Size	Required	
A	3.5"	1.6"	
N	3.5"	1.6"	

Plus 21 Wind Load Case(s)
Plus 1 UBC LL Load Case(s)
Plus 1 BC LL Load Case(s)
Plus 1 DL Load Case(s)

Membr	CSI	P Lbs	Ax1-CSI-Bnd
-----Top Chords-----			
A -Q	0.61	1869	C 0.05 0.56
Q -R	0.30	1734	C 0.06 0.24
R -B	0.23	1364	C 0.03 0.20
B -C	0.35	1091	C 0.02 0.33
C -S	0.25	1369	C 0.02 0.23
S -T	0.42	1683	C 0.06 0.36
T -U	0.65	1805	C 0.05 0.60

MiTek® Online Plus™ APPROX. TRUSS WEIGHT: 277.3 LBS

U -N	0.60	594	C	0.00	0.60
-----Bottom Chords-----					
A -P	0.73	1464	T	0.31	0.42
P -S1	0.73	1305	T	0.27	0.46
S1 -F	0.73	1305	T	0.27	0.46
F -E	0.54	1091	T	0.23	0.31
E -S2	0.73	1292	T	0.27	0.46
S2 -O	0.73	1292	T	0.27	0.46
O -N	0.75	1389	T	0.29	0.46
-----Webs-----					
Q -P	0.08	187	C		
P -R	0.12	314	T		
R -F	0.17	414	C		1 Br
F -B	0.29	542	T		
F -C	0.30	121	T		
E -C	0.28	558	T		
E -S	0.16	391	C		1 Br
S -O	0.09	257	T		
O -T	0.05	154	T		
-----Sliders-----					
U -N	0.34	1337	C		
TL Defl	-0.39" in E -O L/982				
LL Defl	-0.21" in E -O L/999				
Shear // Grain	in U -N 0.31				

Plates for each ply each face.

Plate - MT20	20 Ga, Gross Area			
Plate - MT2H	20 Ga, Gross Area			
Plate - MS18	18 Ga, Gross Area			
Jt Type	Plt Size	X	Y	JSI
A	MT20	3.0x	6.0	1.0 0.6 0.78
Q	MT20	2.0x	4.0	Ctr Ctr 0.30
R	MT20	5.0x	6.0-0.4	0.5 0.49
B	MT20	5.0x	5.0	1.1-3.2 0.77
C	MT20	6.0x	6.0	0.5-0.8 0.66
S	MT20	5.0x	6.0	0.4 0.5 0.50
T	MT20	2.0x	4.0	Ctr Ctr 0.31
U	MT20	3.0x	4.0	Ctr Ctr 0.56
N	MT2H	3.0x10.0-2.3	0.7	0.70
P	MT20	4.0x	5.0	Ctr Ctr 0.27
S1	MT20	4.0x	6.0	Ctr Ctr 0.26
F	MT20	4.0x	8.0	Ctr Ctr 0.26
E	MT20	4.0x	5.0	Ctr Ctr 0.32
S2	MT20	4.0x	6.0	Ctr Ctr 0.62
O	MT20	4.0x	5.0	Ctr Ctr 0.27

REVIEWED BY:
MiTek Industries, Inc.
6904 Parke East Blvd.
Tampa, FL 33610

REFER TO ONLINE PLUS GENERAL NOTES AND SYMBOLS SHEET FOR ADDITIONAL SPECIFICATIONS.

NOTES:
Trusses Manufactured by:
RIDGWAY ROOF TRUSS
Analysis Conforms To:
FBC2010

TPI 2007
This truss has been designed for 20.0 psf LL on the B.C. in areas where a rectangle 3- 6- 0 tall by 2- 0- 0 wide will fit between the B.C. and any other member.
Design checked for 10 psf non-concurrent LL on BC.
Wind Loads - ANSI / ASCE 7-10
Truss is designed as
Components and Claddings* for Exterior zone location.
Wind Speed: 130 mph
Risk Category : II
Mean Roof Height: 25-0
Exposure Category: B
Building Type: Enclosed
TC Dead Load: 4.0 psf
BC Dead Load: 6.0 psf
Max comp. force 1869 Lbs
Max tens. force 1464 Lbs
Connector Plate Fabrication Tolerance = 20%
This truss is designed for a creep factor of 1.5 which is used to calculate total load deflection.

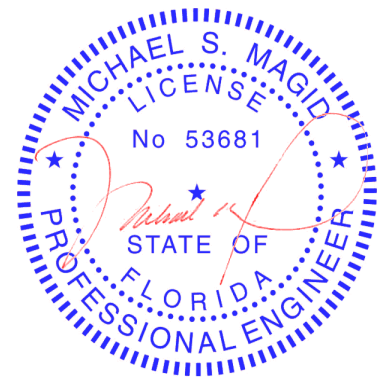

FL Cert. 6634

Job 120440	Mark R42	Quan 1	Type HIPP	Span 320900	Pl-H1 9	Left OH 0	Right OH 0	Engineering T4462862
----------------------	--------------------	-----------	--------------	----------------	------------	--------------	---------------	--------------------------------

18- Rosas- Dreambuilders

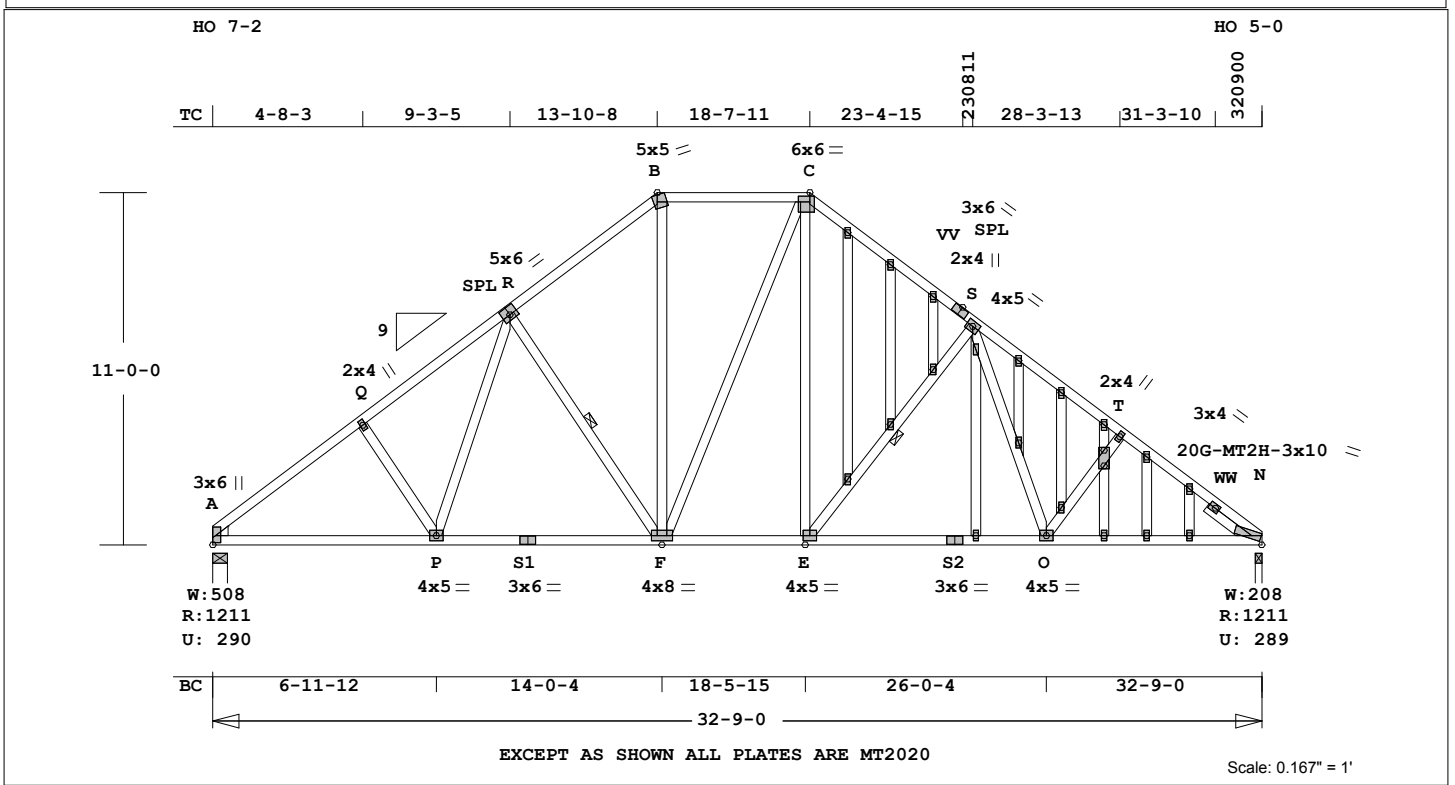

Online Plus -- Version 30.0.011
RUN DATE: 18-JUL-12

Southern Pine lumber design values are those effective
06-01-12 by SPIB//ALSC UON
CSI -Size- ---Lumber----

TC	0.48	2x 4	SP-#2
BC	0.63	2x 4	SP-#2
WB	0.31	2x 4	SP-#3
GW	0.17	2x 4	SP-#3
SL	0.10	2x 4	SP-#3
WG	---	2x 4	SP-#3

Brace truss as follows:
O.C. From To
TC Cont. 0- 0- 0 32- 9- 0
or 48.0" 0- 0- 0 32- 9- 0
BC Cont. 0- 0- 0 32- 9- 0
or 120.0" 0- 0- 0 32- 9- 0
Continuous Lateral Restraint req'd at mid-point of webs:
R -F E -S
Attach CLR with (2)-10d nails at each web.
Refer to BCSI for diagonal restraint requirements.

psf-Ld	Dead	Live
TC	7.0	20.0
BC	10.0	0.0
TC+BC	17.0	20.0
Total	37.0	Spacing 24.0"
Lumber	Duration Factor 1.25	
Plate	Duration Factor 1.25	
	Fb	Fc Ft Emin
TC	1.15	1.10 1.10 1.10
BC	1.10	1.10 1.10 1.10

Total Load Reactions (Lbs)
Jt Down Uplift Horiz-
A 1212 290 U 225 R
N 1212 290 U 225 R

Jt	Brg Size	Required
A	5.5"	1.5"
N	2.5"	2.5"

Plus 21 Wind Load Case(s)
Plus 1 UBC LL Load Case(s)
Plus 1 DL Load Case(s)

Membr	CSI	P Lbs	Axl-CSI-Bnd
-----Top Chords-----			
A -Q	0.48	1586 C	0.04 0.44
Q -R	0.24	1452 C	0.02 0.22
R -B	0.23	1131 C	0.02 0.21

MiTek® Online Plus™ APPROX. TRUSS WEIGHT: 344.3 LBS

B -C	0.23	902 C	0.01 0.22
C -U	0.20	1048 C	0.01 0.19
U -Y	0.16	1120 C	0.07 0.09
Y -CC	0.14	1135 C	0.07 0.07
CC-VV	0.14	1187 C	0.07 0.07
VV-S	0.19	1207 C	0.07 0.12
S -HH	0.20	1481 C	0.08 0.12
HH-LL	0.10	1528 C	0.08 0.02
LL-NN	0.08	1522 C	0.07 0.01
NN-T	0.12	1566 C	0.07 0.05
T -RR	0.12	1604 C	0.07 0.05
RR-TT	0.11	1643 C	0.04 0.07
TT-WW	0.12	1688 C	0.04 0.08
WW-N	0.10	1333 C	0.02 0.08
-----Bottom Chords-----			
A -P	0.63	1271 T	0.26 0.37
P -S1	0.40	1100 T	0.14 0.26
S1-F	0.41	1100 T	0.23 0.18
F -E	0.35	901 T	0.19 0.16
E -S2	0.33	1146 T	0.24 0.09
S2-GG	0.33	1146 T	0.24 0.09
GG-O	0.31	1147 T	0.24 0.07
O -QQ	0.31	1340 T	0.28 0.03
QQ-SS	0.31	1335 T	0.27 0.04
SS-UU	0.31	1335 T	0.27 0.04
UU-N	0.31	1335 T	0.27 0.04
-----Webs-----			
Q -P	0.08	186 C	
P -R	0.10	301 T	
R -F	0.17	414 C	1 Br
F -B	0.31	468 T	
B -C	0.30	119 T	
C -E	0.28	427 T	
E -V	0.14	435 C	0.06 0.08
V -Z	0.27	462 C	0.09 0.18
Z -DD	0.25	414 C	0.07 0.18
DD-S	0.16	435 C	0.06 0.10
S -S	0.14	355 T	0.11 0.03
S -II	0.16	262 T	0.09 0.07
II-O	0.16	265 T	0.09 0.07
O -MM	0.12	267 C	0.01 0.11
MM-PP	0.12	192 C	0.00 0.12
PP-T	0.08	167 C	0.00 0.08
-----Gable Webs-----			
V -U	0.17	50 T	0.02 0.15
Z -Y	0.14	56 C	0.00 0.14
DD-CC	0.06	29 T	0.00 0.06
GG-S	0.08	186 T	0.06 0.02
II-HH	0.06	7 T	0.00 0.06
MM-LL	0.04	89 C	0.00 0.04
PP-NN	0.04	41 T	0.00 0.04
QQ-PP	0.07	75 T	0.01 0.06
SS-RR	0.01	35 T	
UU-TT	0.01	53 T	
-----Sliders-----			
WW-N	0.10	409 C	

TL Defl -0.24" in P -F L/999
LL Defl -0.08" in P -F L/999
Shear // Grain in N -N 1.00

Plates for each ply each face.
Plate - MT20 20 Ga, Gross Area
Plate - MT2H 20 Ga, Gross Area
Plate - MS18 18 Ga, Gross Area
Jt Type Plt Size X Y JSI

A MT20	3.0x 6.0	1.0 0.6 0.66
Q MT20	2.0x 4.0	Ctr Ctr 0.30
R MT20	5.0x 6.0	-0.4 0.5 0.47
B MT20	5.0x 5.0	1.1-3.2 0.62
C MT20	6.0x 6.0	0.5-0.8 0.55
U MT20	2.0x 4.0	Ctr Ctr 0.33
Y MT20	2.0x 4.0	Ctr Ctr 0.32
CC MT20	2.0x 4.0	Ctr Ctr 0.30
VV MT20	3.0x 6.0	Ctr Ctr 0.38
S MT20	4.0x 5.0	Ctr Ctr 0.30
HH MT20	2.0x 4.0	Ctr Ctr 0.34
LL MT20	2.0x 4.0	Ctr Ctr 0.28
NN MT20	2.0x 4.0	Ctr Ctr 0.30
T MT20	2.0x 4.0	Ctr Ctr 0.31
RR MT20	2.0x 4.0	Ctr Ctr 0.34
TT MT20	2.0x 4.0	Ctr Ctr 0.28
WW MT20	3.0x 4.0	Ctr Ctr 0.17
N MT2H	3.0x10.0	-3.3 0.8 0.70
P MT20	4.0x 5.0	Ctr Ctr 0.27
S1 MT20	3.0x 6.0	Ctr Ctr 0.66
F MT20	4.0x 8.0	Ctr Ctr 0.27
E MT20	4.0x 5.0	Ctr Ctr 0.25
S2 MT20	3.0x 6.0	Ctr Ctr 0.45
GG MT20	2.0x 4.0	Ctr Ctr 0.34
O MT20	4.0x 5.0	Ctr Ctr 0.26
QQ MT20	2.0x 4.0	Ctr Ctr 0.33
SS MT20	2.0x 4.0	Ctr Ctr 0.34
UU MT20	2.0x 4.0	Ctr Ctr 0.34
V MT20	2.0x 4.0	Ctr Ctr 0.24
Z MT20	2.0x 4.0	Ctr Ctr 0.21
DD MT20	2.0x 4.0	Ctr Ctr 0.25
S MT20	2.0x 4.0	Ctr Ctr 0.22
II MT20	2.0x 4.0	Ctr Ctr 0.23
MM MT20	2.0x 4.0	Ctr Ctr 0.21
PP MT20	4.0x 8.0	Ctr Ctr 0.30

REVIEWED BY:
MiTek Industries, Inc.
6904 Parke East Blvd.
Tampa, FL 33610

REFER TO ONLINE PLUS GENERAL NOTES AND SYMBOLS SHEET FOR ADDITIONAL SPECIFICATIONS.

NOTES:
Trusses Manufactured by:
RIDGWAY ROOF TRUSS

Analysis Conforms To:
FBC2010
TPI 2007
Design checked for 10 psf non-concurrent LL on BC.
Wind Loads - ANSI / ASCE 7-10
Truss is designed as Components and Claddings* for Exterior zone location.
Wind Speed: 130 mph
Risk Category: II
Mean Roof Height: 25'-0
Exposure Category: B
Building Type: Enclosed
TC Dead Load: 4.0 psf
BC Dead Load: 6.0 psf
Max comp. force 1688 Lbs
Max tens. force 1340 Lbs
Connector Plate Fabrication
Tolerance = 20%
This truss is designed for a creep factor of 1.5 which is used to calculate total load deflection.

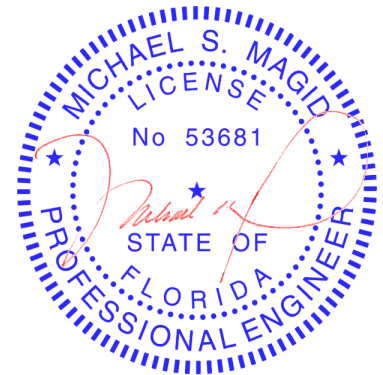

FL Cert. 6634

July 18, 2012

Job 120440	Mark R43	Quan 2	Type SP	Span 330000	Pl-H1 9	Left OH 0	Right OH 0	Engineering T4462863
----------------------	--------------------	-----------	------------	----------------	------------	--------------	---------------	--------------------------------

18- Rosas- Dreambuilders

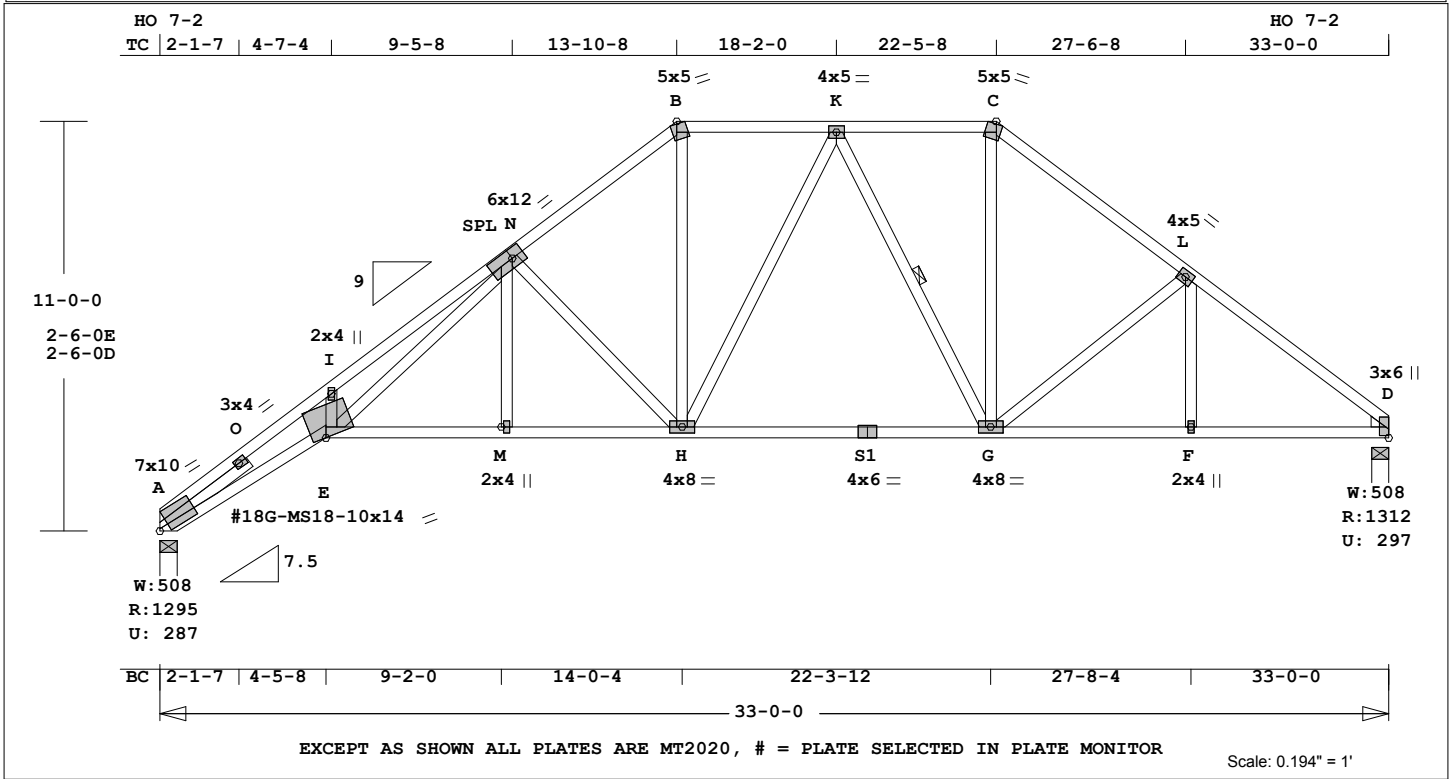

EXCEPT AS SHOWN ALL PLATES ARE MT2020, # = PLATE SELECTED IN PLATE MONITOR

Scale: 0.194" = 1'

Online Plus -- Version 30.0.011
RUN DATE: 18-JUL-12

Southern Pine lumber design values are those effective 06-01-12 by SPIB//ALSC UON

TC	BC	WB	SL	WG	Brace	Continuous	psf-Ld	TC	BC	TC+BC	Total	Lumber	Plate	TC	BC	Total	Jt	A	D	Jt	A	D
0.65	0.89	0.72	0.47	---	0.C.	req'd	7.0	10.0	17.0	37.0	37.0	1.25	1.25	1.15	1.10	1.10	1295	287	1312	5.5"	5.5"	5.5"

Brace truss as follows:
O.C. From To
TC Cont. 0-0-0 33-0-0
or 30.0" 0-0-0 33-0-0
BC Cont. 0-0-0 33-0-0
or 90.0" 0-0-0 33-0-0
Continuous Lateral Restraint req'd at mid-point of webs:
K -G
Attach CLR with (2)-10d nails at each web.
Refer to BCSI for diagonal restraint requirements.

psf-Ld	TC	BC	TC+BC	Total	Lumber	Plate	TC	BC	Total	Jt	A	D
7.0	10.0	17.0	37.0	37.0	1.25	1.25	1.15	1.10	1.10	1295	287	1312

Jt	A	D
1295	287	1312

Jt	A	D
1295	287	1312

Plus 21 Wind Load Case(s)
Plus 1 UBC LL Load Case(s)
Plus 1 BC LL Load Case(s)
Plus 1 DL Load Case(s)

Membr	CSI	P Lbs	Axl	CSI-Bnd	W	R	U
A-O	0.42	3390	C	0.05	508	1295	287
O-I	0.49	5038	C	0.12	508	1295	287
I-N	0.65	4801	C	0.15	508	1295	287
N-B	0.41	1676	C	0.04	508	1295	287
B-K	0.18	1329	C	0.03	508	1295	287
K-C	0.18	1203	C	0.02	508	1295	287
C-L	0.33	1501	C	0.07	508	1295	287
L-D	0.48	1707	C	0.04	508	1295	287
A-E	0.69	4462	T	0.31	508	1295	287
E-M	0.53	1866	T	0.39	508	1295	287
M-H	0.80	1866	T	0.39	508	1295	287
H-S1	0.88	1329	T	0.28	508	1295	287
S1-G	0.89	1329	T	0.28	508	1295	287
G-F	0.74	1351	T	0.28	508	1295	287
F-D	0.72	1351	T	0.28	508	1295	287
E-I	0.09	241	T		508	1295	287
E-N	0.67	2933	T		508	1295	287
M-N	0.05	172	T		508	1295	287
N-H	0.72	795	C		508	1295	287
H-B	0.32	790	T		508	1295	287
H-K	0.11	121	T		508	1295	287
K-G	0.14	310	C	1 Br	508	1295	287
G-C	0.25	639	T		508	1295	287
G-L	0.28	298	C		508	1295	287
F-L	0.04	139	T		508	1295	287
A-O	0.47	1872	C		508	1295	287
TL Defl	-0.77"				508	1295	287
LL Defl	-0.39"				508	1295	287
Hz Disp	LL	DL	TL		508	1295	287
Jt D	0.27"	0.30"	0.56"		508	1295	287
Shear // Grain					508	1295	287
Plates for each ply each face.					508	1295	287
Plate - MT20	18 Ga.	Gross Area			508	1295	287
Plate - MT2H	18 Ga.	Gross Area			508	1295	287
Plate - MS18	18 Ga.	Gross Area			508	1295	287
Jt Type	Plt Size	X	Y	JSI	508	1295	287
A	MT20	7.0x10.0	6.1	4.2	0.84	508	1295
O	MT20	3.0x 4.0	Ctr	Ctr	0.74	508	1295
I	MT20	2.0x 4.0	Ctr	Ctr	0.30	508	1295
N	MT20	6.0x12.0	1.7	1.1	0.90	508	1295
B	MT20	5.0x 5.0	1.1	3.2	0.73	508	1295
K	MT20	4.0x 5.0	Ctr	Ctr	0.24	508	1295
C	MT20	5.0x 5.0	1.1	3.2	0.78	508	1295
L	MT20	4.0x 5.0	Ctr	Ctr	0.32	508	1295
D	MT20	3.0x 6.0	1.0	0.6	0.72	508	1295
E#	MS18	10.0x14.0	0.6	2.2	0.70	508	1295
M	MT20	2.0x 4.0	Ctr	Ctr	0.34	508	1295
H	MT20	4.0x 8.0	Ctr	Ctr	0.32	508	1295
S1	MT20	4.0x 6.0	Ctr	0.2	0.73	508	1295

MiTek® Online Plus™ APPROX. TRUSS WEIGHT: 262.3 LBS

G	MT20	4.0x 8.0	Ctr	Ctr	0.26
F	MT20	2.0x 4.0	Ctr	Ctr	0.34

= Plate Monitor used
REVIEWED BY:
MiTek Industries, Inc.
6904 Parke East Blvd.
Tampa, FL 33610

REFER TO ONLINE PLUS GENERAL NOTES AND SYMBOLS SHEET FOR ADDITIONAL SPECIFICATIONS.

NOTES:
Trusses Manufactured by:
RIDGWAY ROOF TRUSS
Analysis Conforms To:
FBC2010
TPI 2007

This truss has been designed for 20.0 psf LL on the B.C. in areas where a rectangle 3-6-0 tall by 2-0-0 wide will fit between the B.C. and any other member. Design checked for 10 psf non-concurrent LL on BC.

NOTE: USER MODIFIED PLATES
This design may have plates selected through a plate monitor.
Wind Loads - ANSI / ASCE 7-10
Truss is designed as
Components and Claddings*
for Exterior zone location.
Wind Speed: 130 mph
Risk Category : II
Mean Roof Height: 25-0
Exposure Category: B
Building Type: Enclosed
TC Dead Load: 4.0 psf
BC Dead Load: 6.0 psf
Max comp. force 5038 Lbs
Max tens. force 4462 Lbs
Connector Plate Fabrication
Tolerance = 20%
Exceptions: E 0%

This truss is designed for a creep factor of 1.5 which is used to calculate total load deflection.

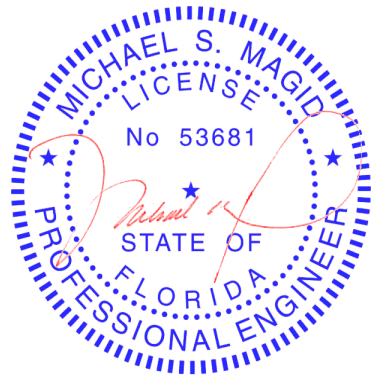

FL Cert. 6634

July 18, 2012

Job 120440	Mark R44	Quan 4	Type PCH3	Span 330000	Pl-H1 9	Left OH 0	Right OH 0	Engineering T4462864
----------------------	--------------------	-----------	--------------	----------------	------------	--------------	---------------	--------------------------------

18- Rosas- Dreambuilders

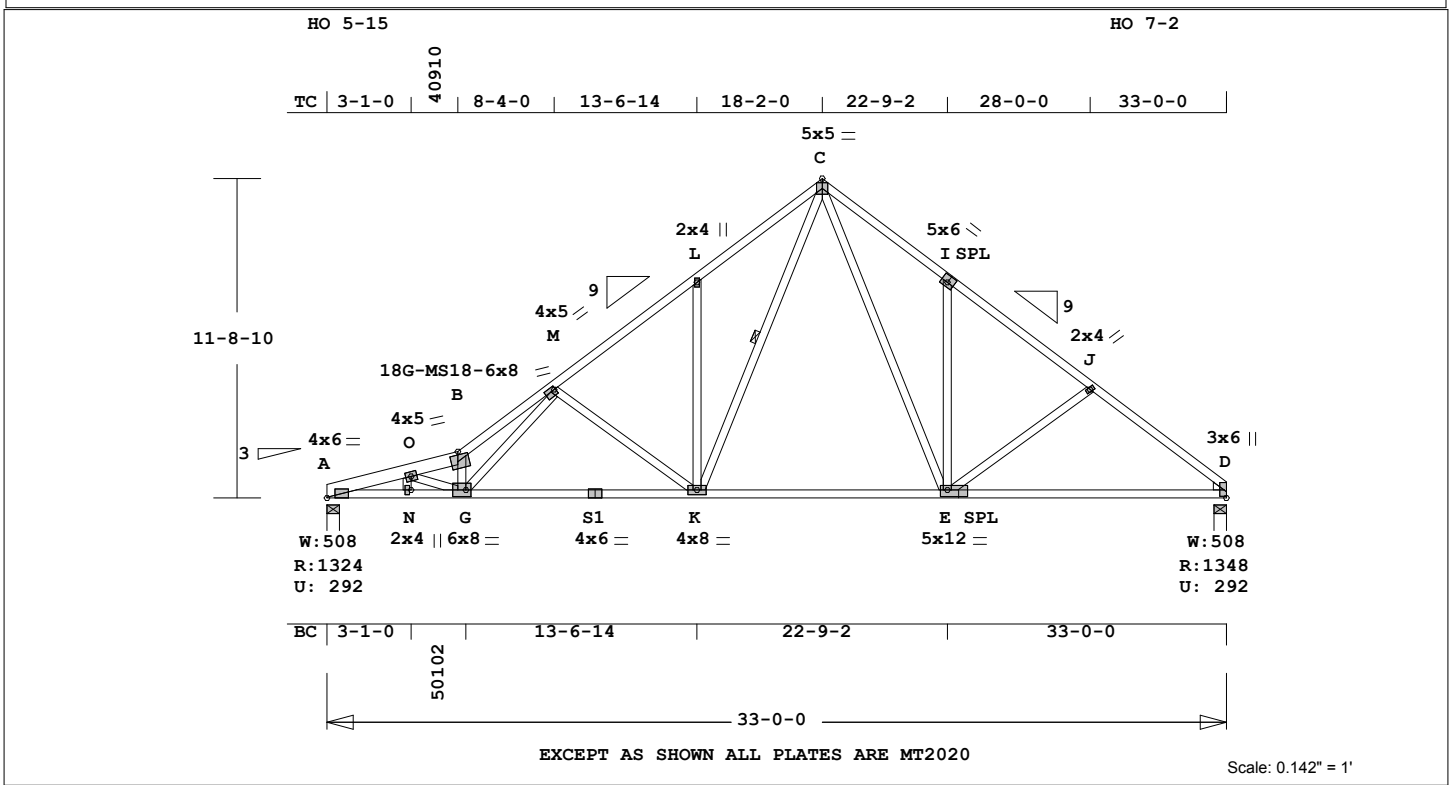

MiTek® Online Plus™ APPROX. TRUSS WEIGHT: 258.7 LBS

Online Plus -- Version 30.0.011
RUN DATE: 18-JUL-12

Southern Pine lumber design values are those effective 06-01-12 by SPIB//ALSC UON

TC	CSI	Size	Lumber
0.56	2x 4	SP-#2	
0.28	2x 6	SP-#2	
0.27	2x 4	SP-#1	
0.82	2x 4	SP-#2	
0.65	2x 4	SP-#1	
0.88	2x 4	SP-#3	
0.61	2x 4	SP-#2	
---	2x 4	SP-#3	

Brace truss as follows:
O.C. From To
TC Cont. 0-0-0 33-0-0
or 30.0" 0-0-0 33-0-0
BC Cont. 0-0-0 33-0-0
or 78.0" 0-0-0 33-0-0

Continuous Lateral Restraint req'd at mid-point of webs:
K-C
Attach CLR with (2)-10d nails at each web.
Refer to BCSI for diagonal restraint requirements.

psf-Ld	Dead	Live		
TC	7.0	20.0		
BC	10.0	0.0		
TC+BC	17.0	20.0		
Total	37.0	Spacing 24.0"		
Lumber	Duration Factor	1.25		
Plate	Duration Factor	1.25		
TC	Fb	Fc	Ft	Emin
BC	1.15	1.10	1.10	1.10
TC	1.10	1.10	1.10	1.10

Total Load Reactions (Lbs)
Jt Down Uplift Horiz-
A 1325 292 U 226 R
D 1348 292 U 239 R

Jt	Brg Size	Required
A	5.5"	1.6"
D	5.5"	1.6"

Plus 21 Wind Load Case(s)
Plus 1 UBC LL Load Case(s)
Plus 1 BC LL Load Case(s)
Plus 1 DL Load Case(s)

Membr	CSI	P Lbs	Axl	CSI-Bnd
A-O	0.17	3757	C	0.04 0.13
O-B	0.28	3881	C	0.04 0.24

B-M	0.27	4691	C	0.16 0.11
M-L	0.17	1791	C	0.03 0.14
L-C	0.15	1792	C	0.06 0.09
C-I	0.30	1601	C	0.04 0.26
I-J	0.32	1580	C	0.06 0.26
J-D	0.56	1789	C	0.05 0.51
-----Bottom Chords-----				
A-N	0.63	3606	T	0.47 0.16
N-G	0.64	3606	T	0.47 0.17
G-S1	0.50	2061	T	0.27 0.23
S1-K	0.65	2061	T	0.27 0.38
K-E	0.59	979	T	0.12 0.47
E-D	0.82	1408	T	0.30 0.52
-----Webs-----				
N-O	0.02	121	C	
O-G	0.07	215	T	
G-B	0.49	1965	C	
G-M	0.61	2615	T	
M-K	0.73	791	C	
K-L	0.40	305	C	
K-C	0.48	1183	T	1 Br
C-E	0.88	770	T	
E-I	0.43	325	C	
E-J	0.22	243	C	

TL Defl -0.61" in G-K L/628
LL Defl -0.36" in K-E L/999
Shear // Grain in K-E 0.28

Plates for each ply each face.

Plate	Material	Gross Area
Plate - MT20	20 Ga	Gross Area
Plate - MT2H	20 Ga	Gross Area
Plate - MS18	18 Ga	Gross Area

Jt	Type	Plt Size	X	Y	JSI
A	MT20	4.0x 6.0	Ctr	0.1	0.93
O	MT20	4.0x 5.0	Ctr	Ctr	0.26
B	MS18	6.0x 8.0	1.0	0.2	0.90
M	MT20	4.0x 5.0-1.4-1.5	0.96		
L	MT20	2.0x 4.0	Ctr	Ctr	0.28
C	MT20	5.0x 5.0	Ctr	Ctr	0.75
I	MT20	5.0x 6.0	0.4	0.5	0.52
J	MT20	2.0x 4.0	Ctr	Ctr	0.31
D	MT20	3.0x 6.0-1.0	0.6	0.75	
N	MT20	2.0x 4.0	Ctr	Ctr	0.34
G	MT20	6.0x 8.0	Ctr	Ctr	0.91
S1	MT20	4.0x 6.0	Ctr	0.2	0.71
K	MT20	4.0x 8.0	Ctr	Ctr	0.67
E	MT20	5.0x12.0-2.0-0.5	0.75		

REVIEWED BY:
MiTek Industries, Inc.
6904 Parke East Blvd.
Tampa, FL 33610

REFER TO ONLINE PLUS GENERAL NOTES AND SYMBOLS SHEET FOR ADDITIONAL SPECIFICATIONS.

NOTES:
Trusses Manufactured by:
RIDGWAY ROOF TRUSS
Analysis Conforms To:
FBC2010

TPI 2007
This truss has been designed for 20.0 psf LL on the B.C. in areas where a rectangle 3- 6- 0 tall by 2- 0- 0 wide will fit between the B.C. and any other member.
Design checked for 10 psf non-concurrent LL on BC.
Wind Loads - ANSI / ASCE 7-10
Truss is designed as Components and Claddings* for Exterior zone location.
Wind Speed: 130 mph
Risk Category: II
Mean Roof Height: 25-0
Exposure Category: B
Building Type: Enclosed
TC Dead Load: 4.0 psf
BC Dead Load: 6.0 psf
Max comp. force 4691 Lbs
Max tens. force 3606 Lbs
Connector Plate Fabrication Tolerance = 20%
This truss is designed for a creep factor of 1.5 which is used to calculate total load deflection.

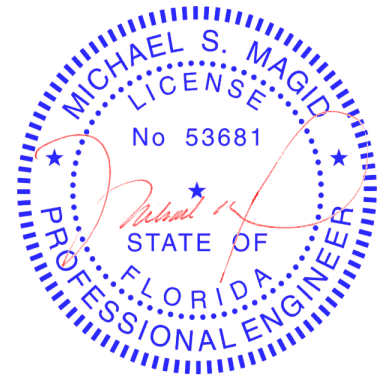

FL Cert. 6634

Job 120440	Mark R45	Quan 1	Type SP	Span 330000	Pl-Hl 9	Left OH 0	Right OH 0	Engineering T4462865
----------------------	--------------------	-----------	------------	----------------	------------	--------------	---------------	-------------------------

18- Rosas- Dreambuilders

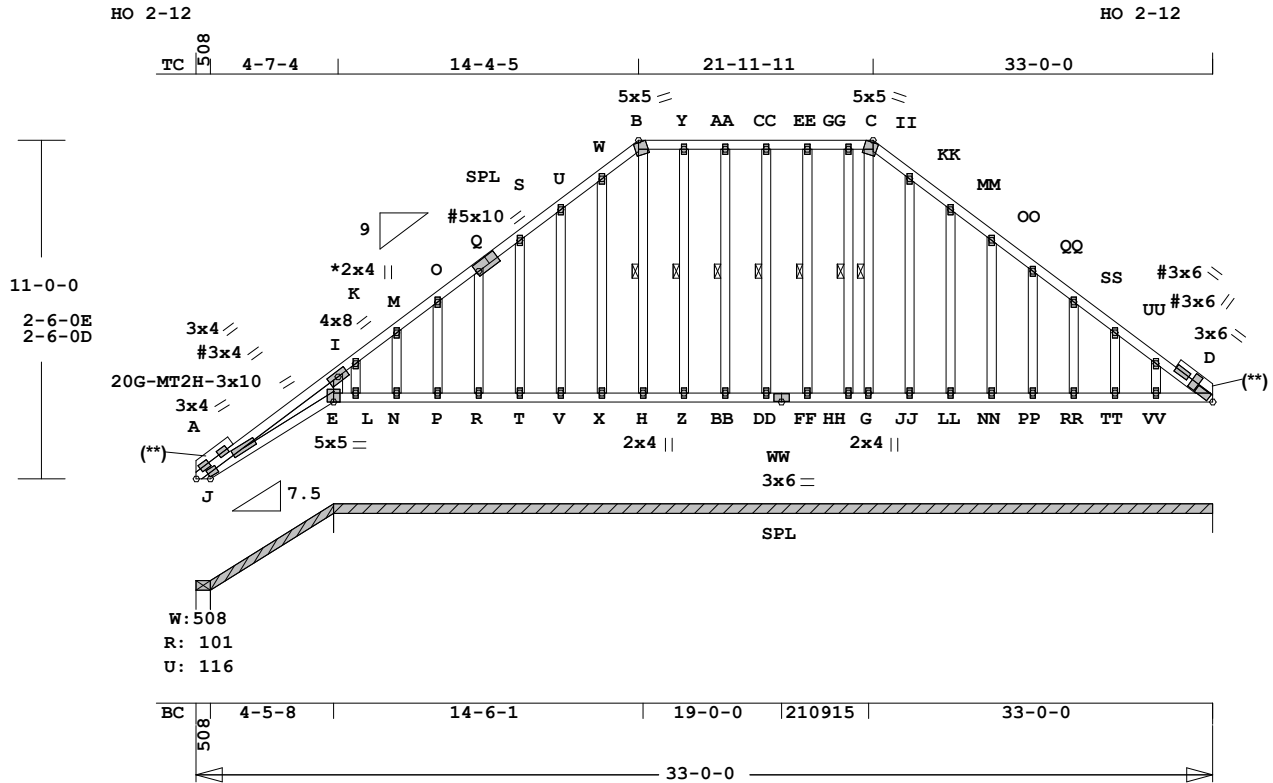

EXCEPT AS SHOWN ALL PLATES ARE MT2020, # = PLATE SELECTED IN PLATE MONITOR
See Joint K For Typical Gable Plate Size and Placement

Scale: 0.160" = 1'

Online Plus -- Version 30.0.011
RUN DATE: 18-JUL-12

Southern Pine Lumber design
values are those effective
06-01-12 by SPIB//ALSC UON
CSI -Size- ---Lumber----
TC 0.04 2x 4 SP-#2 (**)
BC 0.03 2x 4 SP-#2
WB 0.12 2x 4 SP-#3
GW 0.12 2x 4 SP-#3
SL 0.00 2x 4 SP-#3

Brace truss as follows:
O.C. From To
TC Cont. 0- 0- 0 33- 0- 0
or 48.0" 0- 0- 0 33- 0- 0
BC Cont. 0- 0- 0 33- 0- 0
or 72.0" 0- 0- 0 33- 0- 0

Continuous Lateral Restraint
req'd at mid-point of webs:
H-B G-C Z-Y BB-AA
DD-CC FF-EE HH-GG
Attach CLR with (2)-10d nails
at each web.
Refer to BCSI for diagonal
restraint requirements.

psf-Ld Dead Live
TC 7.0 20.0
BC 10.0 0.0
TC+BC 17.0 20.0
Total 37.0 Spacing 24.0"
Lumber Duration Factor 1.25
Plate Duration Factor 1.25
Fb Fc Ft Emin
TC 1.15 1.10 1.10 1.10
BC 1.10 1.10 1.10 1.10

Total Load Reactions (Lbs)
Jt Down Uplift Horiz-
A 101 117 U 205 R
A 100 175 U
E 2348 528 U 199 R

Jt Brg Size Required
A 5.5" 2.2"
A 48.0" 3"-to- 51"
E 342.5" 51"-to- 394"

Plus 21 Wind Load Case(s)
Plus 1 UBC LL Load Case(s)
Plus 1 DL Load Case(s)

Membr CSI P Lbs Ax1-CSI-Bnd
-----Top Chords-----
A -I 0.04 130 T 0.00 0.04
I -K 0.03 133 T 0.00 0.03
K -M 0.02 126 T 0.02 0.00

MiTek® Online Plus™ APPROX. TRUSS WEIGHT: 363.9 LBS											
M -O	0.02	111	T	0.01	0.01	FF-EE	0.12	72	C	1	Br
O -Q	0.02	96	T	0.01	0.01	HH-GG	0.09	52	C	1	Br
Q -S	0.02	81	T	0.01	0.01	JJ-II	0.10	77	C		
S -U	0.02	111	T	0.01	0.01	LL-KK	0.09	86	C		
U -W	0.03	161	T	0.02	0.01	NN-MM	0.06	81	C		
W -B	0.04	195	T	0.03	0.01	PP-OO	0.04	81	C		
B -Y	0.03	180	T	0.03	0.00	RR-QQ	0.02	82	C		
Y -AA	0.03	180	T	0.03	0.00	TT-SS	0.02	78	C		
AA-CC	0.03	180	T	0.03	0.00	VV-UU	0.02	97	C		
CC-EE	0.03	180	T	0.03	0.00	-----Sliders-----					
EE-GG	0.04	180	T	0.03	0.01	A -I	0.00	44	C		
GG-C	0.03	180	T	0.03	0.00						
C -II	0.04	195	T	0.03	0.01						
II-KK	0.03	162	T	0.02	0.01						
KK-MM	0.02	111	T	0.01	0.01						
MM-OO	0.02	64	T	0.01	0.01						
OO-QQ	0.01	60	T	0.00	0.01						
QQ-SS	0.02	75	T	0.01	0.01						
SS-UU	0.02	89	T	0.00	0.02						
UU-D	0.02	129	C	0.00	0.02						
-----Bottom Chords-----											
E -L	0.02	127	T	0.02	0.00						
L -N	0.02	127	T	0.02	0.00						
N -P	0.02	127	T	0.02	0.00						
P -R	0.02	127	T	0.02	0.00						
R -T	0.02	127	T	0.02	0.00						
T -V	0.02	127	T	0.02	0.00						
V -X	0.02	127	T	0.02	0.00						
X -H	0.02	127	T	0.02	0.00						
H -Z	0.02	127	T	0.02	0.00						
Z -BB	0.02	127	T	0.02	0.00						
BB-DD	0.02	127	T	0.02	0.00						
DD-WW	0.02	127	T	0.02	0.00						
WW-FF	0.02	127	T	0.02	0.00						
FF-HH	0.02	127	T	0.02	0.00						
HH-GG	0.02	127	T	0.02	0.00						
G -JJ	0.02	127	T	0.02	0.00						
JJ-LL	0.02	127	T	0.02	0.00						
LL-NN	0.02	127	T	0.02	0.00						
NN-PP	0.02	127	T	0.02	0.00						
PP-RR	0.02	127	T	0.02	0.00						
RR-TT	0.02	127	T	0.02	0.00						
TT-VV	0.02	127	T	0.02	0.00						
VV-D	0.03	127	T	0.02	0.01						
-----Webs-----											
E -I	0.01	40	T								
H -B	0.12	72	C		1	Br					
G -C	0.11	65	C		1	Br					
-----Gable Webs-----											
L -K	0.01	43	T								
N -M	0.02	84	C								
P -O	0.02	81	C								
R -Q	0.04	81	C								
T -S	0.06	81	C								
V -U	0.09	86	C								
X -W	0.11	80	C								
Z -Y	0.12	72	C		1	Br					
BB-AA	0.12	72	C		1	Br					
DD-CC	0.12	72	C		1	Br					

= Plate Monitor used
REVIEWED BY:
MiTek Industries, Inc.
6904 Parke East Blvd.
Tampa, FL 33610

REFER TO ONLINE PLUS GENERAL
NOTES AND SYMBOLS SHEET FOR
ADDITIONAL SPECIFICATIONS.

NOTES: (Continued on page 2 of 2)
Trusses Manufactured by:
RIDGWAY ROOF TRUSS

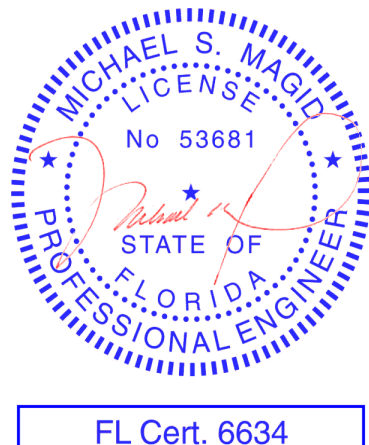

FL Cert. 6634

July 18, 2012

Job 120440	Mark R45	Quan 1	Type SP	Span 330000	Pl-H1 9	Left OH 0	Right OH 0	Engineering T4462865
18- Rosas- Dreambuilders								

Analysis Conforms To:
FBC2010
TPI 2007

Design checked for 10 psf non-concurrent LL on BC.

Truss designed for wind loads in the plane of the truss only. For studs exposed to wind (normal to the face), see Standard Industry Gable End Details as applicable, or consult qualified Building Designer as per ANSI/TPI 1.

NOTE: USER MODIFIED PLATES
This design may have plates selected through a plate monitor.

Wind Loads - ANSI / ASCE 7-10

Truss is designed as Components and Claddings* for Exterior zone location.
Wind Speed: 130 mph
Risk Category : II
Mean Roof Height: 25-0
Exposure Category: B
Building Type: Enclosed
TC Dead Load: 4.0 psf
BC Dead Load: 6.0 psf
Max comp. force 157 Lbs
Max tens. force 195 Lbs

Connector Plate Fabrication
Tolerance = 20%
This truss is designed for a creep factor of 1.5 which is used to calculate total load deflection.

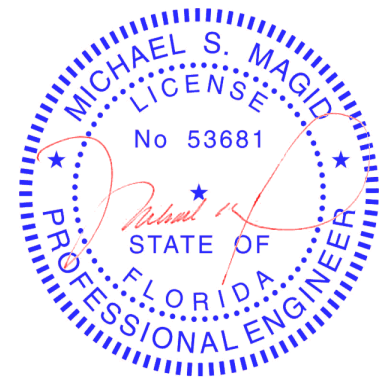

FL Cert. 6634

July 18, 2012

Job 120440	Mark R46	Quan 1	Type TR	Span 150000	Pl-H1 9	Left OH 0	Right OH 0	Engineering T4462866
----------------------	--------------------	-----------	------------	----------------	------------	--------------	---------------	--------------------------------

18- Rosas- Dreambuilders

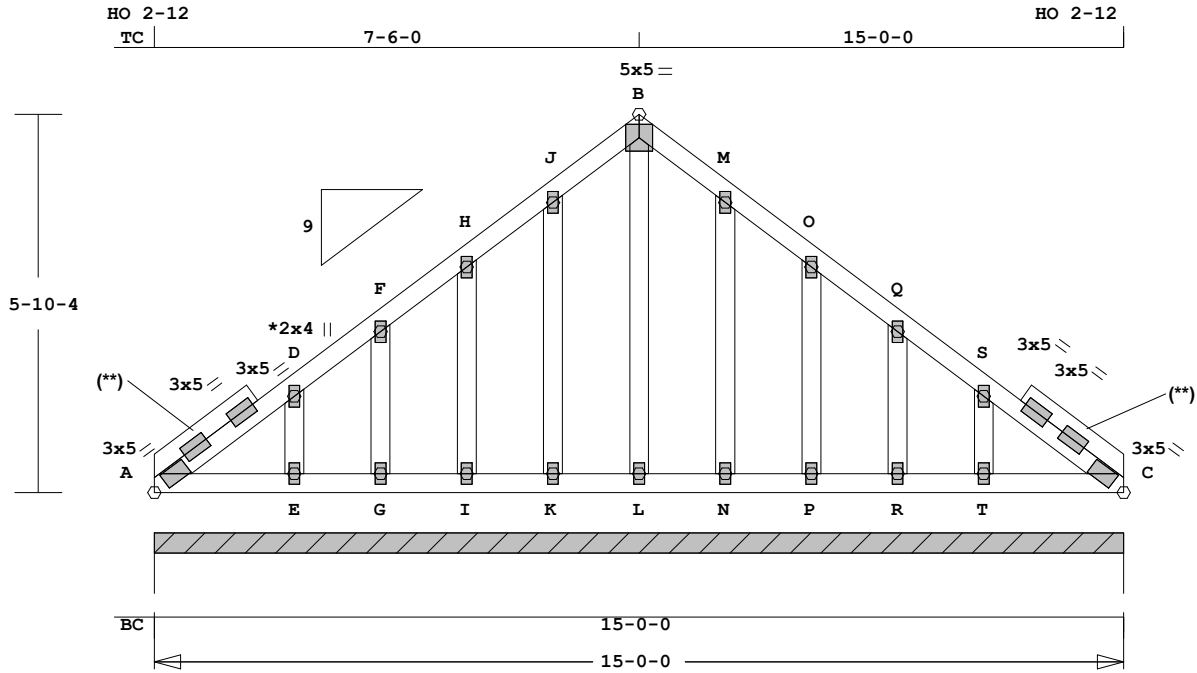

ALL PLATES ARE MT2020

See Joint D For Typical Gable Plate Size and Placement

Scale: 0.337" = 1'

Online Plus -- Version 30.0.011
RUN DATE: 18-JUL-12

Southern Pine lumber design
values are those effective
06-01-12 by SPIB//ALSC UON
CSI -Size- ----Lumber-----
TC 0.03 2x 4 SP-#2 (**)
BC 0.02 2x 4 SP-#2
GW 0.04 2x 4 SP-#3

Brace truss as follows:
O.C. From To
TC Cont. 0- 0- 0 15- 0- 0
or 48.0" 0- 0- 0 15- 0- 0
BC Cont. 0- 0- 0 15- 0- 0
or 72.0" 0- 0- 0 15- 0- 0

psf-Ld	Dead	Live
TC	7.0	20.0
BC	10.0	0.0
TC+BC	17.0	20.0
Total	37.0	Spacing 24.0"
Lumber	Duration Factor 1.25	
Plate	Duration Factor 1.25	
	Fb	Fc
TC	1.15	1.10
BC	1.10	1.10

Total Load Reactions (Lbs)
Jt Down Uplift Horiz-
A 1098 263 U 110 R

Jt Brg Size Required
A 180.0" 0"-to- 180"

Plus 21 Wind Load Case(s)
Plus 1 UBC LL Load Case(s)
Plus 1 DL Load Case(s)

Membr	CSI	P	Lbs	Axl	CSI-Bnd
-----Top Chords-----					
A-D	0.03		112 C	0.01	0.02
D-F	0.02		57 C	0.00	0.02
F-H	0.01		46 C	0.00	0.01
H-J	0.01		48 C	0.00	0.01
J-B	0.01		85 T	0.00	0.01
B-M	0.01		85 T	0.00	0.01
M-O	0.01		48 C	0.00	0.01
O-Q	0.01		46 C	0.00	0.01
Q-S	0.02		57 C	0.00	0.02
S-C	0.03		112 C	0.01	0.02
-----Bottom Chords-----					
A-E	0.02		27 C	0.00	0.02
E-G	0.01		0 T	0.00	0.01
G-I	0.01		0 T	0.00	0.01
I-K	0.01		0 T	0.00	0.01
K-L	0.01		0 T	0.00	0.01
L-N	0.01		0 T	0.00	0.01
N-P	0.01		0 T	0.00	0.01

MiTek® Online Plus™ APPROX. TRUSS WEIGHT: 123.2 LBS

P-R	0.01	0 T	0.00	0.01
R-T	0.01	0 T	0.00	0.01
T-C	0.02	27 C	0.00	0.02
-----Gable Webs-----				
E-D	0.02	111 C		
G-F	0.01	75 C		
I-H	0.03	86 C		
K-J	0.04	75 C		
L-B	0.04	60 C		
N-M	0.04	75 C		
P-O	0.03	86 C		
R-Q	0.01	75 C		
T-S	0.02	111 C		

TL Defl 0.00" in A-E L/999
LL Defl 0.00" in A-E L/999
Shear // Grain in A-D 0.05

Plates for each ply each face.

Plate	Material	Gross Area
Plate - MT20	20 Ga	Gross Area
Plate - MT2H	20 Ga	Gross Area
Plate - MS18	18 Ga	Gross Area

Jt Type	Plt Size	X	Y	JSI
A	MT20	3.0x 5.0	Ctr	0.43
D	MT20	2.0x 4.0	Ctr	0.00
F	MT20	2.0x 4.0	Ctr	0.00
H	MT20	2.0x 4.0	Ctr	0.00
J	MT20	2.0x 4.0	Ctr	0.00
B	MT20	5.0x 5.0	Ctr	0.33
M	MT20	2.0x 4.0	Ctr	0.00
O	MT20	2.0x 4.0	Ctr	0.00
Q	MT20	2.0x 4.0	Ctr	0.00
S	MT20	2.0x 4.0	Ctr	0.00
C	MT20	3.0x 5.0	Ctr	0.43
E	MT20	2.0x 4.0	Ctr	0.00
G	MT20	2.0x 4.0	Ctr	0.00
I	MT20	2.0x 4.0	Ctr	0.00
K	MT20	2.0x 4.0	Ctr	0.00
L	MT20	2.0x 4.0	Ctr	0.00
N	MT20	2.0x 4.0	Ctr	0.00
P	MT20	2.0x 4.0	Ctr	0.00
R	MT20	2.0x 4.0	Ctr	0.00
T	MT20	2.0x 4.0	Ctr	0.00

REVIEWED BY:
MiTek Industries, Inc.
6904 Parke East Blvd.
Tampa, FL 33610

REFER TO ONLINE PLUS GENERAL
NOTES AND SYMBOLS SHEET FOR
ADDITIONAL SPECIFICATIONS.

NOTES:
Trusses Manufactured by:
RIDGWAY ROOF TRUSS
Analysis Conforms To:
FBC2010
TPI 2007
Design checked for 10 psf non-

concurrent LL on BC.
Truss designed for wind loads
in the plane of the truss
only. For studs exposed to
wind (normal to the face),
see Standard Industry Gable
End Details as applicable,
or consult qualified
Building Designer as per
ANSI/TPI 1.
Wind Loads - ANSI / ASCE 7-10
Truss is designed as
Components and Claddings*
for Exterior zone location.
Wind Speed: 130 mph
Risk Category : II
Mean Roof Height: 25-0
Exposure Category: B
Building Type: Enclosed
TC Dead Load: 4.0 psf
BC Dead Load: 6.0 psf
Max comp. force 112 Lbs
Max tens. force 88 Lbs
Connector Plate Fabrication
Tolerance = 20%
This truss is designed for a
creep factor of 1.5 which
is used to calculate total
load deflection.

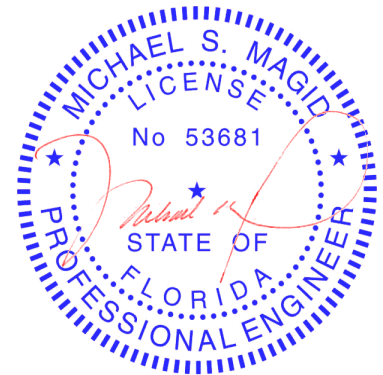

FL Cert. 6634

Job 120440	Mark R47	Quan 1	Type TR	Span 150000	Pl-H1 9	Left OH 0	Right OH 0	Engineering T4462867
----------------------	--------------------	-----------	------------	----------------	------------	--------------	---------------	--------------------------------

18- Rosas- Dreambuilders

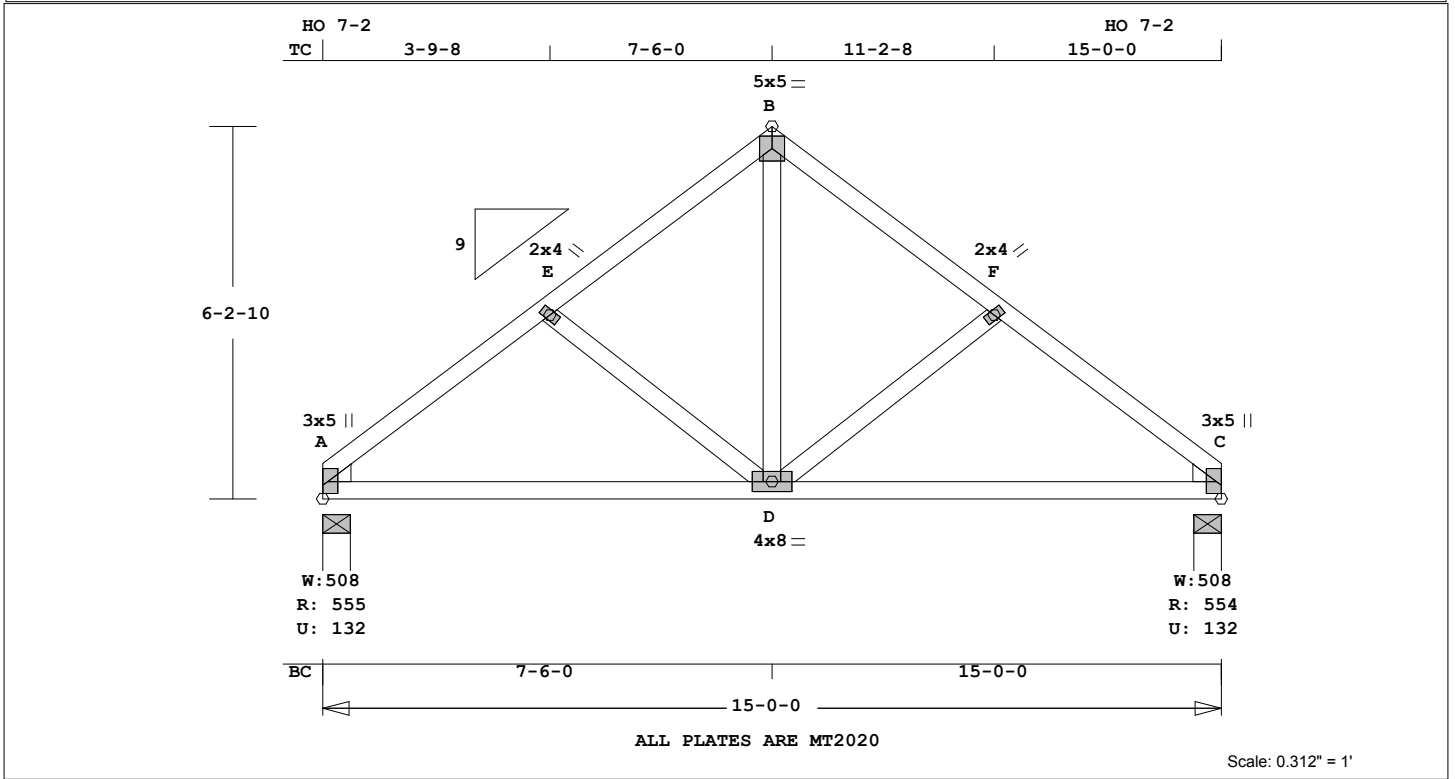

MiTek® Online Plus™ APPROX. TRUSS WEIGHT: 93.8 LBS

Online Plus -- Version 30.0.011
RUN DATE: 18-JUL-12

Southern Pine lumber design values are those effective 06-01-12 by SPIB//ALSC UON

CSI	-Size-	Lumber
TC	0.13 2x 4	SP-#2
BC	0.41 2x 4	SP-#2
WB	0.14 2x 4	SP-#3
PB	---	2x 4 SP-#3

Brace truss as follows:

O.C.	From	To
TC Cont.	0- 0- 0 15- 0- 0	or 48.0"
BC Cont.	0- 0- 0 15- 0- 0	or 120.0"

psf-Ld	Dead	Live		
TC	7.0	20.0		
BC	10.0	0.0		
TC+BC	17.0	20.0		
Total	37.0	Spacing 24.0"		
Lumber	Duration Factor	1.25		
Plate	Duration Factor	1.25		
	Fb	Fc	Ft	Emin
TC	1.15	1.10	1.10	1.10
BC	1.10	1.10	1.10	1.10

Total Load Reactions (Lbs)

Jt	Down	Uplift	Horiz-
A	555	133 U	113 R
C	555	133 U	113 R

Jt	Brg Size	Required
A	5.5"	1.5"
C	5.5"	1.5"

Plus 21 Wind Load Case(s)
Plus 1 UBC LL Load Case(s)
Plus 1 DL Load Case(s)

Membr	CSI	P	Lbs	Ax1-CSI-Bnd
-----Top Chords-----				
A	-E	0.13	630 C	0.03 0.10
E	-B	0.11	475 C	0.00 0.11

B - F	0.11	475 C	0.00	0.11
F - C	0.13	630 C	0.03	0.10
-----Bottom Chords-----				
A - D	0.41	513 T	0.06	0.35
D - C	0.41	513 T	0.06	0.35
-----Webs-----				
E - D	0.10	201 C		
D - B	0.14	404 T		
D - F	0.10	201 C		
TL Defl	-0.10"	in D - C	L/999	
LL Defl	-0.05"	in D - C	L/999	
Shear // Grain	in A - D	0.17		

Plates for each ply each face.
Plate - MT20 20 Ga, Gross Area
Plate - MT2H 20 Ga, Gross Area
Plate - MS18 18 Ga, Gross Area
Jt Type Plt Size X Y JSI
A MT20 3.0x 5.0 1.5 0.9 0.49
E MT20 2.0x 4.0 Ctr Ctr 0.12
B MT20 5.0x 5.0 Ctr Ctr 0.33
F MT20 2.0x 4.0 Ctr Ctr 0.12
C MT20 3.0x 5.0-1.5 0.9 0.49
D MT20 4.0x 8.0 Ctr Ctr 0.14

REVIEWED BY:
MiTek Industries, Inc.
6904 Parke East Blvd.
Tampa, FL 33610

REFER TO ONLINE PLUS GENERAL NOTES AND SYMBOLS SHEET FOR ADDITIONAL SPECIFICATIONS.

NOTES:
Trusses Manufactured by:
RIDGWAY ROOF TRUSS
Analysis Conforms To:
FBC2010
TPI 2007

This truss has been designed for 20.0 psf LL on the B.C. in areas where a rectangle 3- 6- 0 tall by 2- 0- 0 wide will fit between the B.C.

and any other member.
Design checked for 10 psf non-concurrent LL on BC.
Wind Loads - ANSI / ASCE 7-10
Truss is designed as Components and Claddings* for Exterior zone location.
Wind Speed: 130 mph
Risk Category : II
Mean Roof Height: 25-0
Exposure Category: B
Building Type: Enclosed
TC Dead Load: 4.0 psf
BC Dead Load: 6.0 psf
Max comp. force 630 Lbs
Max tens. force 513 Lbs
Connector Plate Fabrication Tolerance = 20%
This truss is designed for a creep factor of 1.5 which is used to calculate total load deflection.

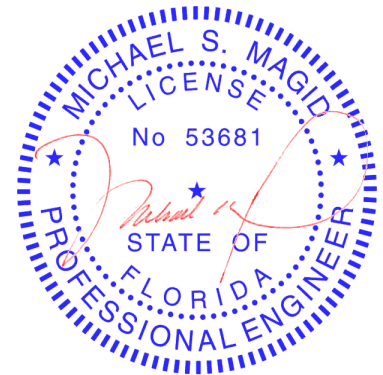

FL Cert. 6634

Job 120440	Mark R48	Quan 1	Type TR	Span 210800	P1-H1 9	Left OH 0	Right OH 0	Engineering T4462868
----------------------	--------------------	-----------	------------	----------------	------------	--------------	---------------	--------------------------------

18- Rosas- Dreambuilders

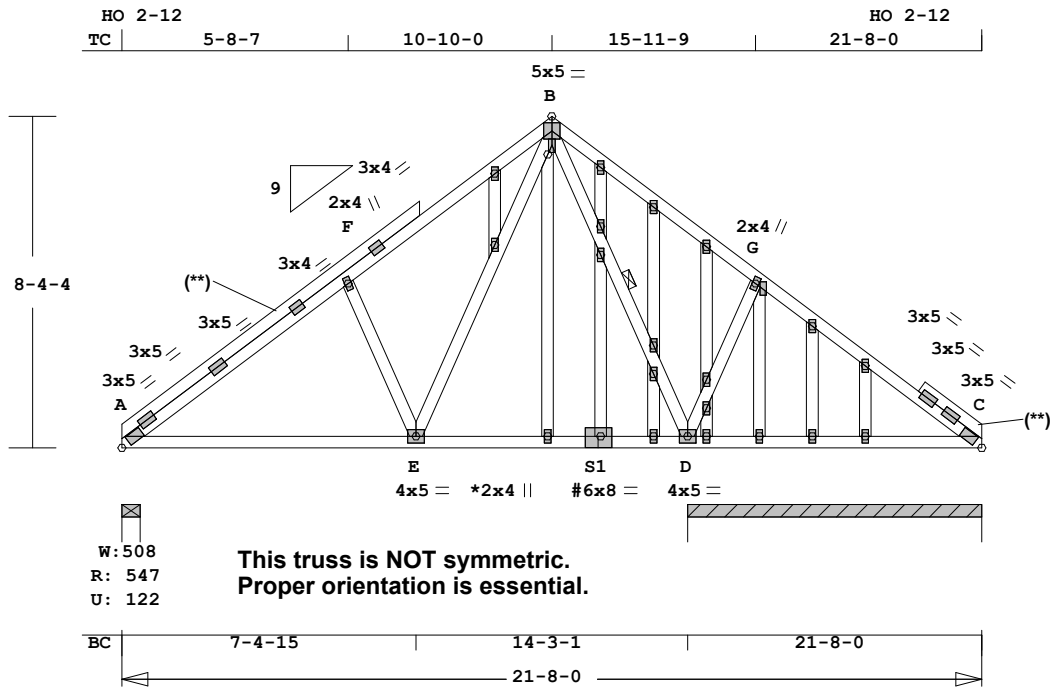

W: 508
R: 547
U: 122

**This truss is NOT symmetric.
Proper orientation is essential.**

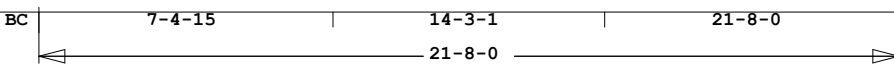

ALL PLATES ARE MT2020, # = PLATE SELECTED IN PLATE MONITOR
See * For Typical Gable Plate Size and Placement

Scale: 0.20" = 1'

Online Plus -- Version 30.0.011
RUN DATE: 18-JUL-12

Southern Pine lumber design values are those effective 06-01-12 by SPIB//ALSC UON
CSI -Size- ---Lumber---
TC 0.35 2x 4 SP-#2 (**)
BC 0.36 2x 4 SP-#2
WB 0.23 2x 4 SP-#3
PB --- 2x 4 SP-#3

Brace truss as follows:
O.C. From To
TC Cont. 0-0-0 21-8-0
or 48.0" 0-0-0 21-8-0
BC Cont. 0-0-0 21-8-0
or 120.0" 0-0-0 21-8-0

Continuous Lateral Restraint req'd at mid-point of webs: B-D
Attach CLR with (2)-10d nails at each web.
Refer to BCSI for diagonal restraint requirements.

psf-Ld	Dead	Live		
TC	7.0	20.0		
BC	10.0	0.0		
TC+BC	17.0	20.0		
Total	37.0	Spacing 24.0"		
Lumber	Duration Factor	1.25		
Plate	Duration Factor	1.25		
	Fb	Fc	Ft	Emin
TC	1.15	1.10	1.10	1.10
BC	1.10	1.10	1.10	1.10

Total Load Reactions (Lbs)			
Jt	Down	Uplift	Horiz-
A	547	123 U	161 R
D	1044	258 U	161 R

Jt	Brg Size	Required
A	5.5"	5.5"
D	88.9"	171"-to- 260"

Plus 21 Wind Load Case(s)
Plus 1 UBC LL Load Case(s)
Plus 1 DL Load Case(s)

Membr	CSI	P	Lbs	Ax1-CSI-Bnd
---Top Chords---				
A-F	0.30	568	C	0.00 0.30
F-B	0.28	518	C	0.00 0.28
B-G	0.35	182	C	0.00 0.35
G-C	0.35	198	C	0.00 0.35

MiTek® Online Plus™ APPROX. TRUSS WEIGHT: 228.6 LBS

-----Bottom Chords-----				
A-E	0.36	509	T	0.05 0.31
E-S1	0.31	241	T	0.02 0.29
S1-D	0.33	241	T	0.02 0.31
D-C	0.33	169	T	0.01 0.32

-----Webs-----				
F-E	0.13	291	C	
E-B	0.23	461	T	
B-D	0.16	366	C	1 Br
D-G	0.14	318	C	

TL Defl -0.14" in A-E L/999
LL Defl -0.06" in A-E L/999
Shear // Grain in G-C 0.18

Plates for each ply each face.
Plate - MT20 20 Ga, Gross Area
Plate - MT2H 20 Ga, Gross Area
Plate - MS18 20 Ga, Gross Area

Jt Type	Plt Size	X	Y	JSI
A	MT20	3.0x	5.0	Ctr Ctr 0.43
F	MT20	2.0x	4.0	Ctr Ctr 0.31
B	MT20	5.0x	5.0	Ctr Ctr 0.46
G	MT20	2.0x	4.0	Ctr Ctr 0.30
C	MT20	3.0x	5.0	Ctr Ctr 0.43
E	MT20	4.0x	5.0	Ctr Ctr 0.25
S1#	MT20	6.0x	8.0	0.1 1.4 0.34
D	MT20	4.0x	5.0	Ctr Ctr 0.25

= Plate Monitor used
11 Gable studs to be attached with 2.0x4.0 plates each end.
REVIEWED BY:
MiTek Industries, Inc.
6904 Parke East Blvd.
Tampa, FL 33610

REFER TO ONLINE PLUS GENERAL NOTES AND SYMBOLS SHEET FOR ADDITIONAL SPECIFICATIONS.

NOTES:
Trusses Manufactured by:
RIDGWAY ROOF TRUSS
Analysis Conforms To:
FBC2010
TPI 2007
Design checked for 10 psf non-concurrent LL on BC.
Truss designed for wind loads in the plane of the truss only. For studs exposed to wind (normal to the face), see Standard Industry Gable End Details as applicable, or consult qualified

Building Designer as per ANSI/TPI 1.
NOTE: USER MODIFIED PLATES
This design may have plates selected through a plate monitor.

Wind Loads - ANSI / ASCE 7-10
Truss is designed as Components and Claddings* for Exterior zone location.
Wind Speed: 130 mph
Risk Category : II
Mean Roof Height: 25-0
Exposure Category: B
Building Type: Enclosed
TC Dead Load: 4.0 psf
BC Dead Load: 6.0 psf
Max comp. force 568 Lbs
Max tens. force 509 Lbs
Connector Plate Fabrication Tolerance = 20%
This truss is designed for a creep factor of 1.5 which is used to calculate total load deflection.

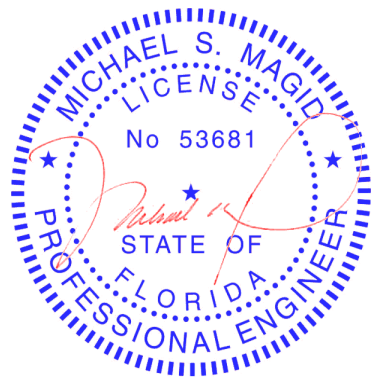

FL Cert. 6634

July 18, 2012

Job 120440	Mark R49	Quan 1	Type TR	Span 210800	Pl-H1 9	Left OH 0	Right OH 0	Engineering T4462869
----------------------	--------------------	-----------	------------	----------------	------------	--------------	---------------	--------------------------------

18- Rosas- Dreambuilders

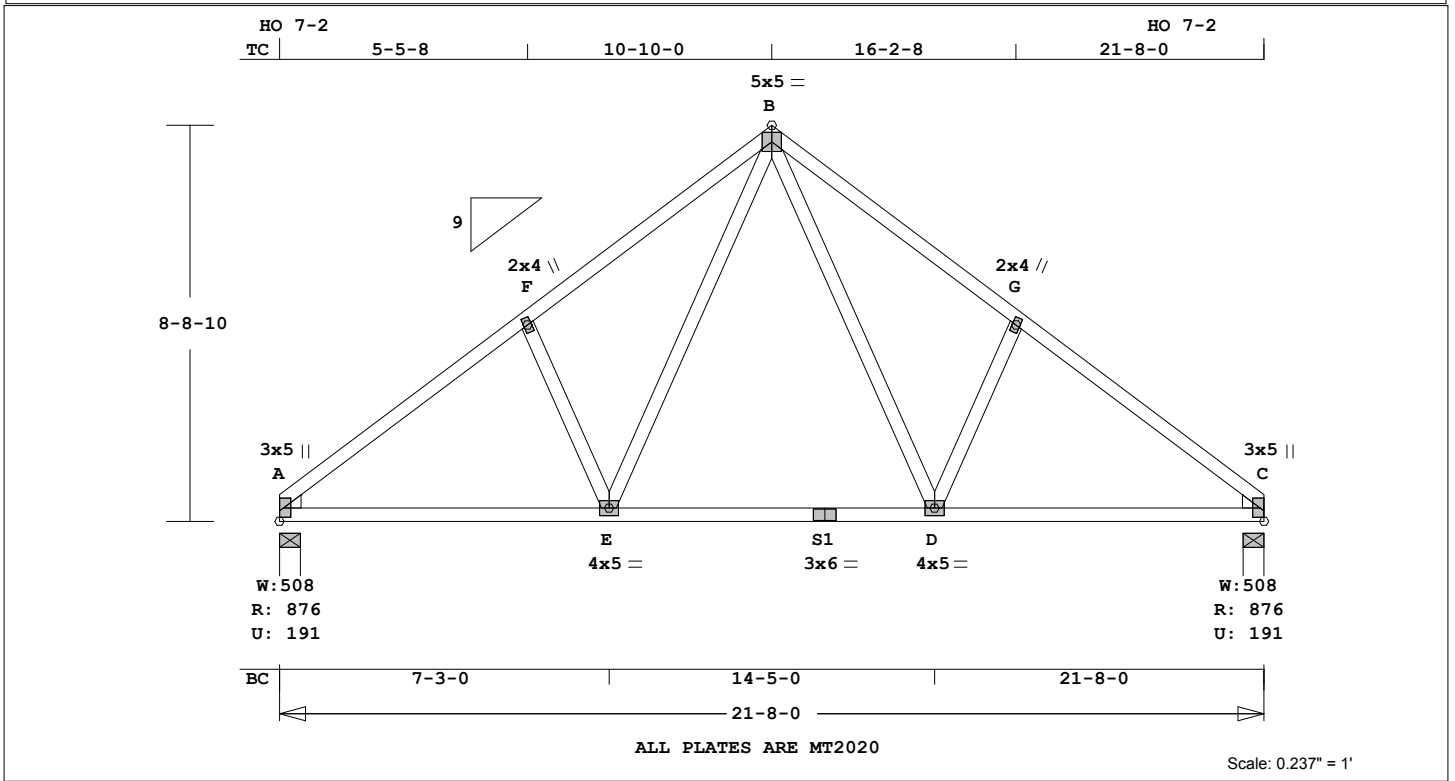

MiTek® Online Plus™ APPROX. TRUSS WEIGHT: 144.5 LBS

Online Plus -- Version 30.0.011
RUN DATE: 18-JUL-12

Southern Pine lumber design values are those effective 06-01-12 by SPIB//ALSC UON

CSI -Size-	Lumber----
TC 0.34	2x 4 SP-#2
BC 0.62	2x 4 SP-#2
WB 0.24	2x 4 SP-#3
WG ---	2x 4 SP-#3

Brace truss as follows:

O.C.	From	To
TC Cont.	0- 0- 0	21- 8- 0
or 48.0"	0- 0- 0	21- 8- 0
BC Cont.	0- 0- 0	21- 8- 0
or 120.0"	0- 0- 0	21- 8- 0

psf-Ld	Dead	Live
TC	7.0	20.0
BC	10.0	0.0
TC+BC	17.0	20.0
Total	37.0	Spacing 24.0"
Lumber Duration Factor	1.25	
Plate Duration Factor	1.25	
	Fb	Fc Ft Emin
TC	1.15	1.10 1.10 1.10
BC	1.10	1.10 1.10 1.10

Total Load Reactions (Lbs)

Jt	Down	Uplift	Horiz-
A	876	192 U	164 R
C	876	192 U	164 R

Jt	Brg Size	Required
A	5.5"	1.5"
C	5.5"	1.5"

Plus 21 Wind Load Case(s)
Plus 1 UBC LL Load Case(s)
Plus 1 BC LL Load Case(s)
Plus 1 DL Load Case(s)

Membr	CSI	P Lbs	Axl	CSI-Bnd
-----Top Chords-----				
A -F	0.34	1070	C	0.01 0.33
F -B	0.28	954	C	0.03 0.25
B -G	0.28	954	C	0.03 0.25
G -C	0.34	1070	C	0.01 0.33

-----Bottom Chords-----

A -E	0.48	849	T	0.18	0.30
E -S1	0.62	575	T	0.12	0.50
S1-D	0.62	575	T	0.12	0.50
D -C	0.48	849	T	0.18	0.30

-----Webs-----

F -E	0.13	274	C
E -B	0.24	470	T
B -D	0.24	470	T
D -G	0.13	274	C

TL Defl -0.26" in E -D L/970
LL Defl -0.17" in E -D L/999
Shear // Grain in E -S1 0.19

Plates for each ply each face.
Plate - MT20 20 Ga, Gross Area
Plate - MT2H 20 Ga, Gross Area
Plate - MS18 18 Ga, Gross Area

Jt Type	Plt Size	X	Y	JSI
A	MT20	3.0x	5.0	1.0 0.5 0.57
F	MT20	2.0x	4.0	Ctr Ctr 0.29
B	MT20	5.0x	5.0	Ctr Ctr 0.46
G	MT20	2.0x	4.0	Ctr Ctr 0.29
C	MT20	3.0x	5.0-1.0	0.5 0.57
E	MT20	4.0x	5.0	Ctr Ctr 0.26
S1	MT20	3.0x	6.0	Ctr Ctr 0.75
D	MT20	4.0x	5.0	Ctr Ctr 0.26

REVIEWED BY:
MiTek Industries, Inc.
6904 Parke East Blvd.
Tampa, FL 33610

REFER TO ONLINE PLUS GENERAL NOTES AND SYMBOLS SHEET FOR ADDITIONAL SPECIFICATIONS.

NOTES:
Trusses Manufactured by:
RIDGWAY ROOF TRUSS
Analysis Conforms To:
FBC2010
TPI 2007
This truss has been designed for 20.0 psf LL on the B.C. in areas where a rectangle 3- 6- 0 tall by 2- 0- 0 wide will fit between the B.C.

and any other member.
Design checked for 10 psf non-concurrent LL on BC.
Wind Loads - ANSI / ASCE 7-10
Truss is designed as Components and Claddings* for Exterior zone location.
Wind Speed: 130 mph
Risk Category : II
Mean Roof Height: 25-0
Exposure Category: B
Building Type: Enclosed
TC Dead Load: 4.0 psf
BC Dead Load: 6.0 psf
Max comp. force 1070 Lbs
Max tens. force 849 Lbs
Connector Plate Fabrication Tolerance = 20%
This truss is designed for a creep factor of 1.5 which is used to calculate total load deflection.

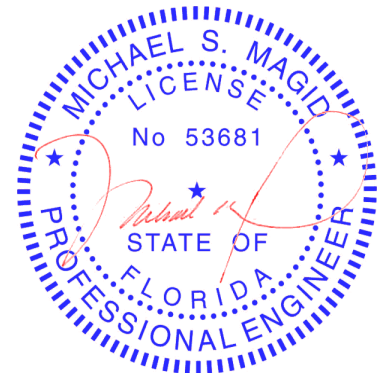

FL Cert. 6634

Job 120440	Mark R50	Quan 1*2P	Type TR	Span 210800	Pl-H1 9	Left OH 0	Right OH 0	Engineering T4462870
----------------------	--------------------	---------------------	-------------------	-----------------------	-------------------	---------------------	----------------------	--------------------------------

18- Rosas- Dreambuilders

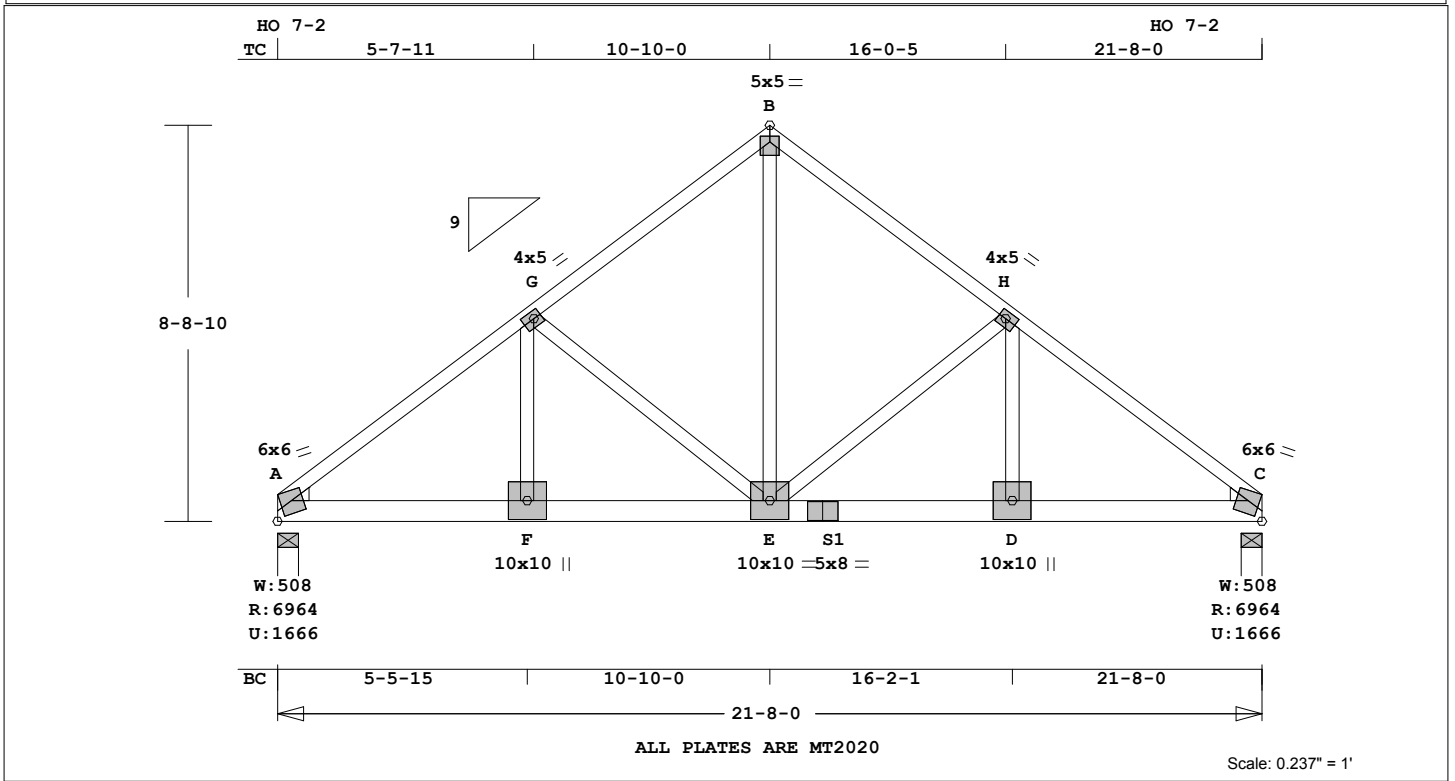

Online Plus -- Version 30.0.011
 RUN DATE: 18-JUL-12

 * 2-Ply Truss *

Southern Pine lumber design values are those effective
 06-01-12 by SPIB//ALSC UON
 CSI -Size- ---Lumber---
 TC 0.29 2x 4 SP-#1
 BC 0.48 2x 6 SP-2400f-2.0E
 WB 0.58 2x 4 SP-#3
 -- 0.47 2x 4 SP-#1
 E -B
 PB --- 2x 4 SP-#3

Brace truss as follows:
 O.C. From To
 TC Cont. 0- 0- 0 21- 8- 0
 or 48.0" 0- 0- 0 21- 8- 0
 BC Cont. 0- 0- 0 21- 8- 0
 or 120.0" 0- 0- 0 21- 8- 0

psf-Ld	Dead	Live		
TC	7.0	20.0		
BC	10.0	0.0		
TC+BC	17.0	20.0		
Total	37.0	Spacing 24.0"		
Lumber	Duration Factor	1.25		
Plate	Duration Factor	1.25		
	Fb	Fc	Ft	Emin
TC	1.00	1.00	1.00	1.00
BC	1.00	1.00	1.00	1.00

Total Load Reactions (Lbs)
 Jt Down Uplift Horiz-
 A 6964 1667 U 164 R
 C 6964 1667 U 164 R

Jt	Brg Size	Required
A	5.5"	2.9"
C	5.5"	2.9"

LC# 1 Girder Loading
 Dur Fctrs - Lbr 1.25 Plt 1.25
 plf - Dead Live* From To
 TC V 14 40 0.0' 21.7'
 BC V 281 308 0.0' 21.7'

Plus 21 Wind Load Case(s)
 Plus 1 UBC LL Load Case(s)
 Plus 1 DL Load Case(s)

Membr	CSI	P	Lbs	Axl	CSI-Bnd
-----Top Chords-----					
A	-G	0.29	8299	C	0.21 0.08
B	-B	0.25	5767	C	0.16 0.09
G	-H	0.25	5767	C	0.16 0.09
H	-C	0.29	8299	C	0.21 0.08
-----Bottom Chords-----					
A	-F	0.48	6626	T	0.16 0.32
F	-E	0.47	6626	T	0.16 0.31

MiTek® Online Plus™ APPROX. TRUSS WEIGHT: 169.2 LBS

E	-S1	0.47	6626	T	0.16	0.31
S1	-D	0.35	6626	T	0.16	0.19
D	-C	0.48	6626	T	0.16	0.32

-----Webs-----
 F -G 0.58 2884 T
 G -E 0.58 2571 C
 E -B 0.47 6595 T
 E -H 0.58 2571 C
 D -H 0.58 2884 T

TL Defl -0.25" in E -D L/999
 LL Defl -0.11" in E -D L/999
 Shear // Grain in F -E 0.64

Plates for each ply each face.
 Plate - MT20 20 Ga, Gross Area
 Plate - MT2H 20 Ga, Gross Area
 Plate - MS18 18 Ga, Gross Area
 Jt Type Plt Size X Y JSI
 A MT20 6.0x 6.0 2.0 1.0 0.97
 G MT20 4.0x 5.0 0.4-0.3 0.85
 B MT20 5.0x 5.0 Ctr-1.0 0.87
 H MT20 4.0x 5.0 0.4-0.3 0.85
 C MT20 6.0x 6.0-2.0 1.0 0.97
 F MT20 10.0x10.0 Ctr Ctr 0.59
 E MT20 10.0x10.0 Ctr Ctr 0.50
 S1 MT20 5.0x 8.0 Ctr Ctr 0.77
 D MT20 10.0x10.0 Ctr Ctr 0.59

REVIEWED BY:
 MiTek Industries, Inc.
 6904 Parke East Blvd.
 Tampa, FL 33610

REFER TO ONLINE PLUS GENERAL NOTES AND SYMBOLS SHEET FOR ADDITIONAL SPECIFICATIONS.

NOTES:

Trusses Manufactured by:
 RIDGWAY ROOF TRUSS

Analysis Conforms To:
 FBC2010
 TPI 2007

Girder Common
 Loading BC
 Span 32- 9- 0

2 COMPLETE TRUSSES REQUIRED.
 Fasten together in staggered pattern. (1/2" bolts -OR- SDS3 screws -OR- 10d nails as each layer is applied.)

Rows	Nails	Screws	Bolts
TC 1	12	24	0
BC 2	12	24	0
WB 1	8	8	

Web Connection Exception --
 Space screws or nails for the following webs-
 G -E @ 4" o.c.
 E -H @ 4" o.c.
 Design checked for 10 psf non-

concurrent LL on BC.
 Use properly rated hangers for loads framing into girder truss.

Wind Loads - ANSI / ASCE 7-10
 Truss is designed as Components and Claddings* for Exterior zone location.
 Wind Speed: 130 mph
 Risk Category : II
 Mean Roof Height: 25-0
 Exposure Category: B
 Building Type: Enclosed
 TC Dead Load: 4.0 psf
 BC Dead Load: 6.0 psf
 Max comp. force 8299 Lbs
 Max tens. force 6626 Lbs
 Connector Plate Fabrication Tolerance = 20%
 This truss is designed for a creep factor of 1.5 which is used to calculate total load deflection.

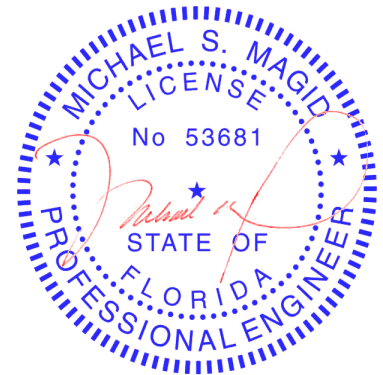

FL Cert. 6634

Job 120440	Mark R51	Quan 1	Type TR	Span 170200	Pl-H1 9	Left OH 0	Right OH 0	Engineering T4462871
----------------------	--------------------	-----------	------------	----------------	------------	--------------	---------------	--------------------------------

18- Rosas- Dreambuilders

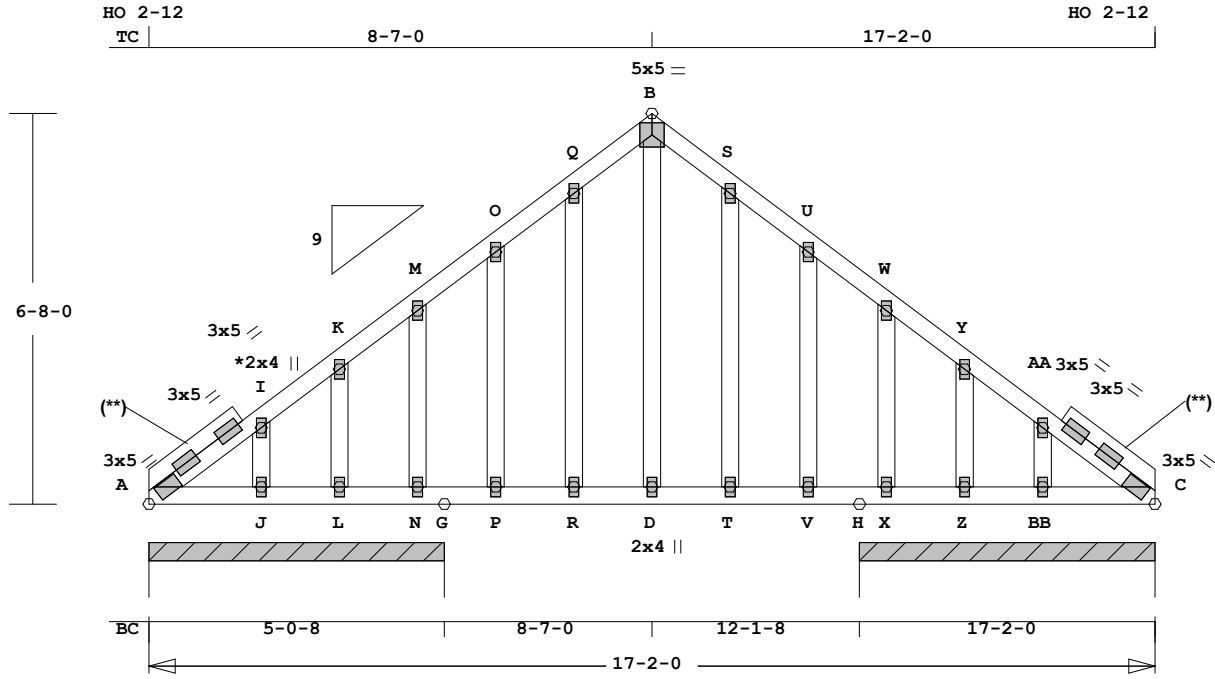

ALL PLATES ARE MT2020

See Joint I For Typical Gable Plate Size and Placement

Scale: 0.305" = 1'

Online Plus -- Version 30.0.011
RUN DATE: 18-JUL-12

Southern Pine lumber design values are those effective
06-01-12 by SPIB//ALSC UON
CSI -Size- ---Lumber---
TC 0.09 2x 4 SP-#2 (**)
BC 0.14 2x 4 SP-#2
WB 0.05 2x 4 SP-#3
GW 0.05 2x 4 SP-#3

Brace truss as follows:
O.C. From To
TC Cont. 0- 0- 0 17- 2- 0
or 48.0" 0- 0- 0 17- 2- 0
BC Cont. 0- 0- 0 17- 2- 0
or 120.0" 0- 0- 0 17- 2- 0

psf-Ld Dead Live
TC 7.0 20.0
BC 10.0 0.0
TC+BC 17.0 20.0
Total 37.0 Spacing 24.0"
Lumber Duration Factor 1.25
Plate Duration Factor 1.25
Fb Fc Ft Emin
TC 1.00 1.00 1.00 1.00
BC 1.00 1.00 1.00 1.00

Total Load Reactions (Lbs)
Jt Down Uplift Horiz-
N 629 151 U 127 R
X 629 151 U 127 R

Jt Brg Size Required
N 60.5" 0"-to- 61"
X 60.5" 146"-to- 206"

LC# 1 Standard Loading
Dur Fctrs - Lbr 1.25 Plt 1.25
plf - Dead Live* From To
TC V 14 40 0.0' 17.2'
BC V 20 0 0.0' 17.2'

Plus 21 Wind Load Case(s)
Plus 1 UBC LL Load Case(s)
Plus 1 DL Load Case(s)

Membr CSI P Lbs Ax1-CSI-Bnd
-----Top Chords-----
A -I 0.02 258 C 0.00 0.02
I -K 0.02 251 C 0.00 0.02
K -M 0.09 229 C 0.00 0.09
M -O 0.09 268 C 0.00 0.09
O -Q 0.08 244 C 0.00 0.08

MiTek® Online Plus™ APPROX. TRUSS WEIGHT: 150.4 LBS			
Q -B	0.05	227 C	0.00 0.05
B -S	0.05	227 C	0.00 0.05
S -U	0.08	244 C	0.00 0.08
U -W	0.09	268 C	0.00 0.09
W -Y	0.09	229 C	0.00 0.09
Y -AA	0.02	251 C	0.00 0.02
AA -C	0.02	258 C	0.00 0.02
-----Bottom Chords-----			
A -J	0.03	213 T	0.02 0.01
J -L	0.03	213 T	0.03 0.00
L -N	0.10	213 T	0.00 0.10
N -P	0.14	213 T	0.04 0.10
P -R	0.12	213 T	0.04 0.08
R -D	0.14	213 T	0.04 0.10
D -T	0.14	213 T	0.04 0.10
T -V	0.12	213 T	0.04 0.08
V -X	0.14	213 T	0.04 0.10
X -Z	0.14	213 T	0.04 0.10
Z -BB	0.05	213 T	0.04 0.01
BB -C	0.05	213 T	0.04 0.01
-----Webs-----			
D -B	0.05	153 T	
-----Gable Webs-----			
J -I	0.02	98 C	
L -K	0.01	53 T	
N -M	0.05	157 C	
P -O	0.01	46 T	
R -Q	0.02	46 T	
T -S	0.02	46 T	
V -U	0.01	46 T	
X -W	0.05	157 C	
Z -Y	0.01	53 T	
BB-AA	0.02	99 C	

Reviewed By:			
MiTek Industries, Inc.			
6904 Parke East Blvd.			
Tampa, FL 33610			
REFER TO ONLINE PLUS GENERAL NOTES AND SYMBOLS SHEET FOR ADDITIONAL SPECIFICATIONS.			
NOTES:			
Trusses Manufactured by:			
RIDGWAY ROOF TRUSS			
Analysis Conforms To:			
FBC2010			
TPI 2007			
Design checked for 10 psf non-concurrent LL on BC.			
Truss designed for wind loads in the plane of the truss only. For studs exposed to wind (normal to the face), see Standard Industry Gable End Details as applicable, or consult qualified Building Designer as per ANSI/TPI 1.			
Wind Loads - ANSI / ASCE 7-10			
Truss is designed as Components and Claddings* for Exterior zone location.			
Wind Speed: 130 mph			
Risk Category : II			
Mean Roof Height: 25-0			
Exposure Category: B			
Building Type: Enclosed			
TC Dead Load: 4.0 psf			
BC Dead Load: 6.0 psf			
Max comp. force 268 Lbs			
Max tens. force 213 Lbs			
Connector Plate Fabrication Tolerance = 20%			
This truss is designed for a creep factor of 1.5 which is used to calculate total load deflection.			

TL Defl -0.02" in P -R L/999
LL Defl -0.01" in P -R L/999
Shear // Grain in N -P 0.09

Plates for each ply each face.			
Plate - MT20 20 Ga, Gross Area			
Plate - MT2H 20 Ga, Gross Area			
Plate - MS18 18 Ga, Gross Area			
Jt Type	Plt Size	X	Y JSI
A	MT20	3.0x 5.0	Ctr Ctr 0.43
I	MT20	2.0x 4.0	Ctr Ctr 0.00
K	MT20	2.0x 4.0	Ctr Ctr 0.00
M	MT20	2.0x 4.0	Ctr Ctr 0.00
O	MT20	2.0x 4.0	Ctr Ctr 0.00
Q	MT20	2.0x 4.0	Ctr Ctr 0.00
B	MT20	5.0x 5.0	Ctr Ctr 0.33
S	MT20	2.0x 4.0	Ctr Ctr 0.00
U	MT20	2.0x 4.0	Ctr Ctr 0.00
W	MT20	2.0x 4.0	Ctr Ctr 0.00
Y	MT20	2.0x 4.0	Ctr Ctr 0.00
AA	MT20	2.0x 4.0	Ctr Ctr 0.00
C	MT20	3.0x 5.0	Ctr Ctr 0.43
J	MT20	2.0x 4.0	Ctr Ctr 0.00

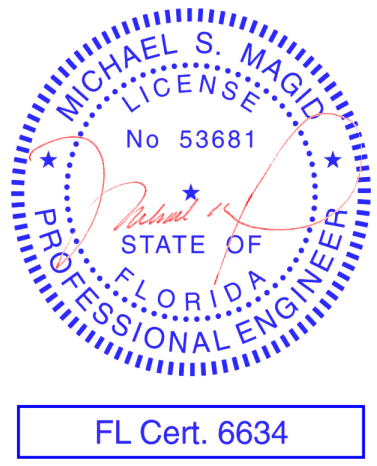

FL Cert. 6634

July 18, 2012

Job 120440	Mark R52	Quan 2	Type TR	Span 170200	Pl-H1 9	Left OH 0	Right OH 0	Engineering T4462872
----------------------	--------------------	-----------	------------	----------------	------------	--------------	---------------	-------------------------

18- Rosas- Dreambuilders

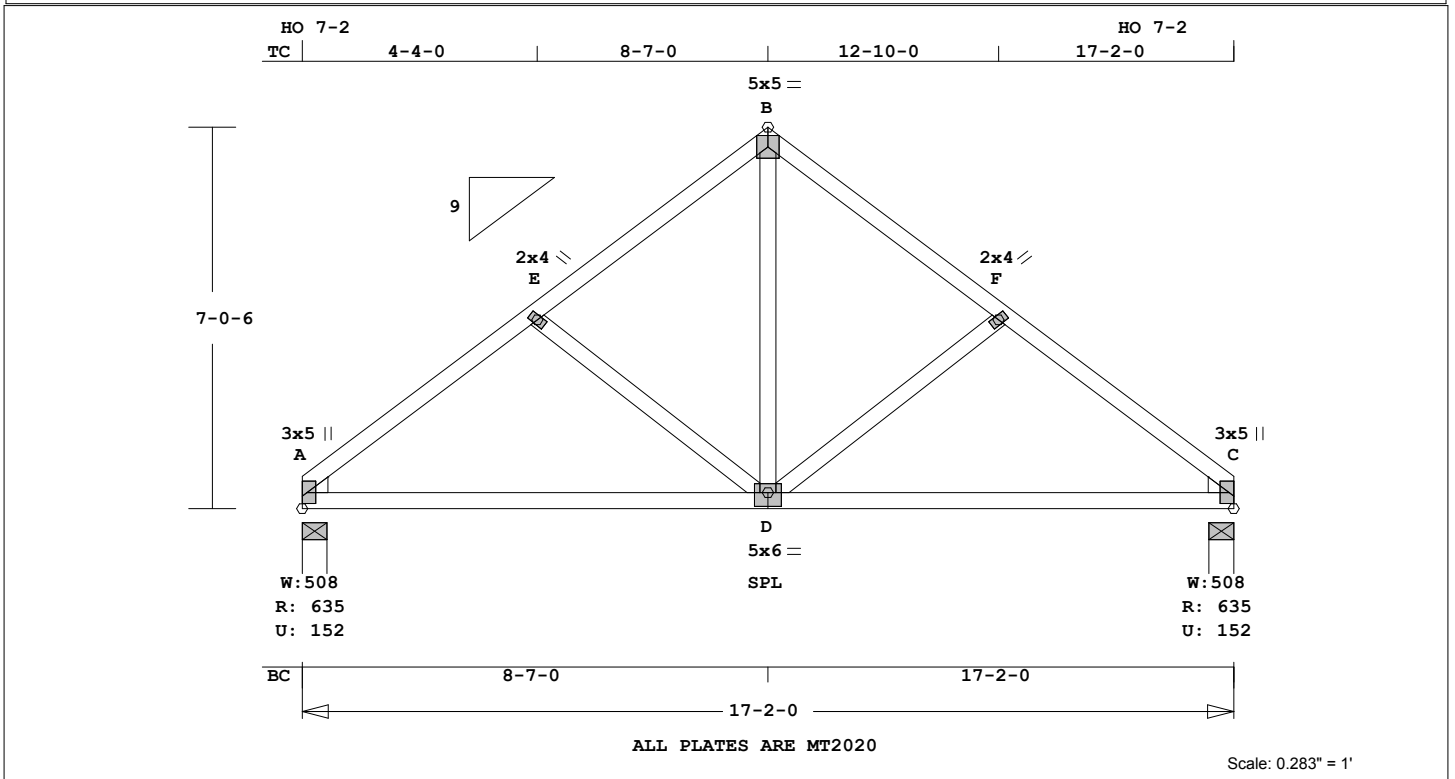

MiTek® Online Plus™ APPROX. TRUSS WEIGHT: 107.1 LBS

Online Plus -- Version 30.0.011
RUN DATE: 18-JUL-12

Southern Pine lumber design values are those effective

06-01-12 by SPIB//ALSC UON

CSI	-Size-	Lumber
TC	0.16 2x 4	SP-#2
BC	0.54 2x 4	SP-#2
WB	0.16 2x 4	SP-#3
PB	--- 2x 4	SP-#3

Brace truss as follows:

O.C.	From	To
TC Cont.	0- 0- 0	17- 2- 0
or	48.0"	0- 0- 0
BC Cont.	0- 0- 0	17- 2- 0
or	120.0"	0- 0- 0

psf-Ld	Dead	Live		
TC	7.0	20.0		
BC	10.0	0.0		
TC+BC	17.0	20.0		
Total	37.0	Spacing 24.0"		
Lumber	Duration Factor	1.25		
Plate	Duration Factor	1.25		
	Fb	Fc	Ft	Emin
TC	1.15	1.10	1.10	1.10
BC	1.10	1.10	1.10	1.10

Total Load Reactions (Lbs)

Jt	Down	Uplift	Horiz-
A	635	152 U	130 R
C	635	152 U	130 R

Jt	Brg Size	Required
A	5.5"	1.5"
C	5.5"	1.5"

Plus 21 Wind Load Case(s)
Plus 1 UBC LL Load Case(s)
Plus 1 DL Load Case(s)

Membr	CSI	P	Lbs	Ax1-CSI-Bnd
-----Top Chords-----				
A	-E	0.16	729 C	0.00 0.16
E	-B	0.16	544 C	0.00 0.16

B - F	0.16	544 C	0.00	0.16
F - C	0.16	729 C	0.00	0.16
-----Bottom Chords-----				
A - D	0.54	595 T	0.07	0.47
D - C	0.54	595 T	0.07	0.47
-----Webs-----				
E - D	0.15	234 C		
D - B	0.16	468 T		
D - F	0.15	234 C		

TL Defl -0.17" in D -C L/999
LL Defl -0.08" in D -C L/999
Shear // Grain in A -D 0.19

Plates for each ply each face.
Plate - MT20 20 Ga, Gross Area
Plate - MT2H 20 Ga, Gross Area
Plate - MS18 18 Ga, Gross Area
Jt Type Plt Size X Y JSI
A MT20 3.0x 5.0 1.5 0.9 0.49
E MT20 2.0x 4.0 Ctr Ctr 0.29
B MT20 5.0x 5.0 Ctr Ctr 0.33
F MT20 2.0x 4.0 Ctr Ctr 0.29
C MT20 3.0x 5.0-1.5 0.9 0.49
D MT20 5.0x 6.0 Ctr-0.5 0.99

REVIEWED BY:
MiTek Industries, Inc.
6904 Parke East Blvd.
Tampa, FL 33610

REFER TO ONLINE PLUS GENERAL NOTES AND SYMBOLS SHEET FOR ADDITIONAL SPECIFICATIONS.

NOTES:
Trusses Manufactured by:
RIDGWAY ROOF TRUSS
Analysis Conforms To:
FBC2010
TPI 2007

This truss has been designed for 20.0 psf LL on the B.C. in areas where a rectangle 3- 6- 0 tall by 2- 0- 0 wide will fit between the B.C.

and any other member.
Design checked for 10 psf non-concurrent LL on BC.
Wind Loads - ANSI / ASCE 7-10
Truss is designed as Components and Claddings* for Exterior zone location.
Wind Speed: 130 mph
Risk Category : II
Mean Roof Height: 25-0
Exposure Category: B
Building Type: Enclosed
TC Dead Load: 4.0 psf
BC Dead Load: 6.0 psf
Max comp. force 729 Lbs
Max tens. force 595 Lbs
Connector Plate Fabrication Tolerance = 20%
This truss is designed for a creep factor of 1.5 which is used to calculate total load deflection.

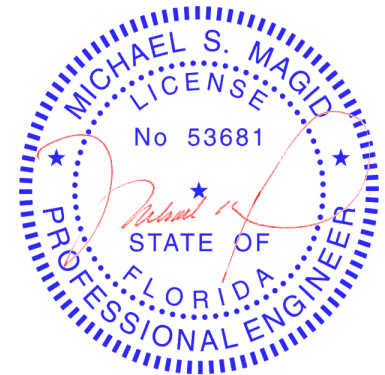

FL Cert. 6634

Job 120440	Mark R53	Quan 1*2P	Type TR	Span 170200	Pl-H1 9	Left OH 0	Right OH 0	Engineering T4462873
----------------------	--------------------	--------------	------------	----------------	------------	--------------	---------------	-------------------------

18- Rosas- Dreambuilders

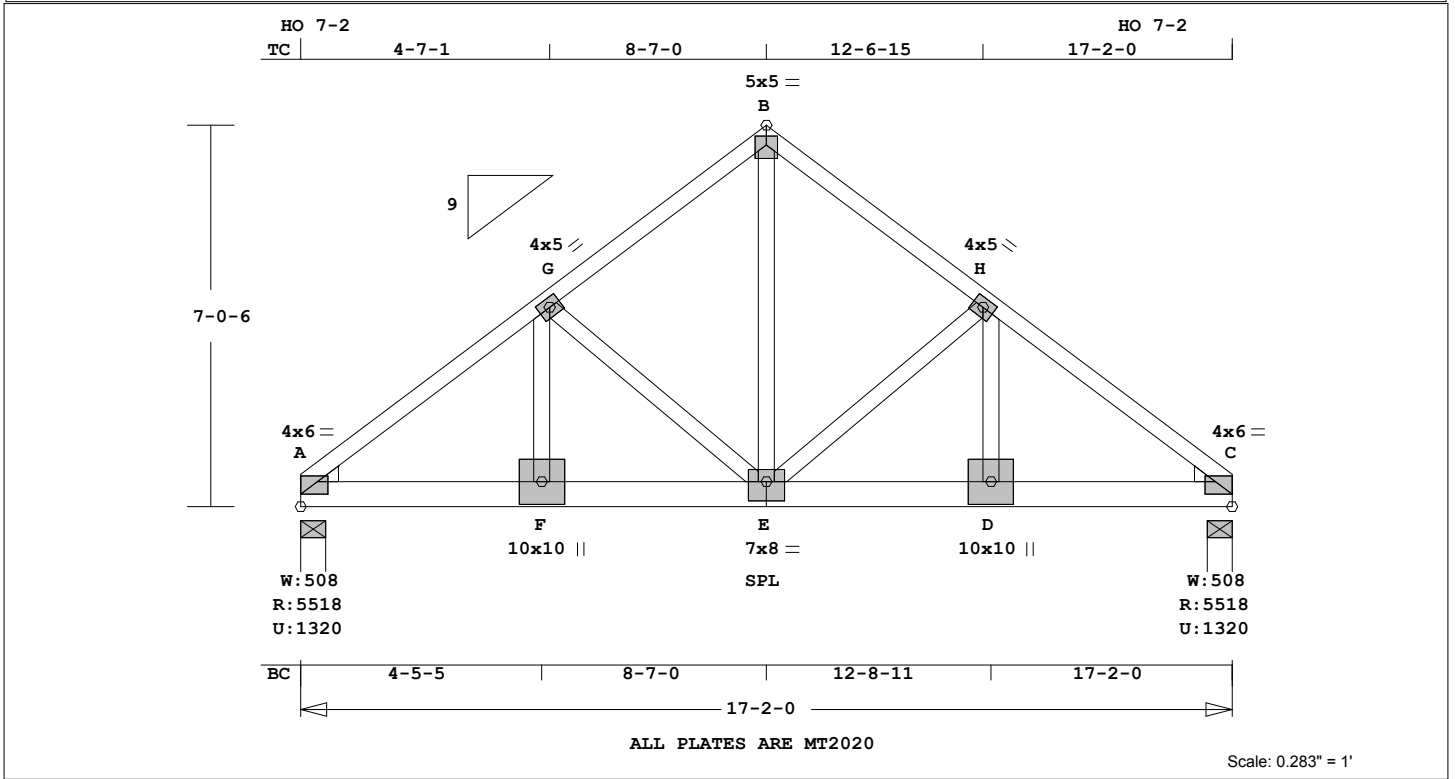

MiTek® Online Plus™ APPROX. TRUSS WEIGHT: 134.3 LBS

Online Plus -- Version 30.0.011
 RUN DATE: 18-JUL-12

 * 2-Ply Truss *

Southern Pine lumber design values are those effective 06-01-12 by SPIB//ALSC UON

TC	0.35	2x 4	SP-#2
BC	0.36	2x 6	SP-2400F-2.0E
WB	0.60	2x 4	SP-#2
--	0.43	2x 4	SP-#3
PF	--	2x 4	SP-#3

H - C	0.35	6337 C	0.19	0.16
-----Bottom Chords-----				
A - F	0.36	5053 T	0.12	0.24
F - E	0.30	5053 T	0.12	0.18
E - D	0.30	5053 T	0.12	0.18
D - C	0.36	5053 T	0.12	0.24
-----Webs-----				
F - G	0.43	2146 T		
G - E	0.32	1888 C		
E - B	0.60	5129 T		
E - H	0.32	1888 C		
D - H	0.43	2146 T		

Design checked for 10 psf non-concurrent LL on BC.
 Use properly rated hangers for loads framing into girder truss.
 Wind Loads - ANSI / ASCE 7-10
 Truss is designed as
 Components and Claddings* for Exterior zone location.
 Wind Speed: 130 mph
 Risk Category : II
 Mean Roof Height: 25-0
 Exposure Category: B
 Building Type: Enclosed
 TC Dead Load: 4.0 psf
 BC Dead Load: 6.0 psf
 Max comp. force 6337 Lbs
 Max tens. force 5129 Lbs
 Connector Plate Fabrication Tolerance = 20%
 This truss is designed for a creep factor of 1.5 which is used to calculate total load deflection.

Brace truss as follows:

TC Cont.	0-0-0	17-2-0
or	48.0"	17-2-0
BC Cont.	0-0-0	17-2-0
or	120.0"	17-2-0

psf-Ld	Dead	Live		
TC	7.0	20.0		
BC	10.0	0.0		
TC+BC	17.0	20.0		
Total	37.0	24.0"		
Lumber	Duration Factor	1.25		
Plate	Duration Factor	1.25		
	Fb	Fc	Ft	Emin
TC	1.00	1.00	1.00	1.00
BC	1.00	1.00	1.00	1.00

Total Load Reactions (Lbs)

Jt	Down	Uplift	Horiz-
A	5518	1321 U	130 R
C	5518	1321 U	130 R

Jt	Brg Size	Required
A	5.5"	2.3"
C	5.5"	2.3"

LC# 1 Girder Loading

Dur	Fctrs	Lbr	1.25	Plt	1.25
TC	V	14	40	0.0'	17.2'
BC	V	281	308	0.0'	17.2'

Plus 21 Wind Load Case(s)
 Plus 1 UBC LL Load Case(s)
 Plus 1 DL Load Case(s)

Membr	CSI	P Lbs	Ax1-CSI-Bnd
-----Top Chords-----			
A - G	0.35	6337 C	0.19 0.16
G - B	0.22	4499 C	0.13 0.09
B - H	0.22	4499 C	0.13 0.09

TL Defl -0.16" in F -E L/999
 LL Defl -0.07" in F -E L/999
 Shear // Grain in A -F 0.54

Plates for each ply each face.
 Plate - MT20 20 Ga, Gross Area
 Plate - MT2H 20 Ga, Gross Area
 Plate - MS18 18 Ga, Gross Area
 Jt Type Plt Size X Y JSI
 A MT20 4.0x 6.0 1.2 0.7 1.00
 G MT20 4.0x 5.0 Ctr Ctr 0.76
 B MT20 5.0x 5.0 Ctr-0.5 0.82
 H MT20 4.0x 5.0 Ctr Ctr 0.76
 C MT20 4.0x 6.0-1.2 0.7 1.00
 F MT20 10.0x10.0 Ctr Ctr 0.44
 E MT20 7.0x 8.0 Ctr-0.8 0.79
 D MT20 10.0x10.0 Ctr Ctr 0.44

REVIEWED BY:
 MiTek Industries, Inc.
 6904 Parke East Blvd.
 Tampa, FL 33610

REFER TO ONLINE PLUS GENERAL NOTES AND SYMBOLS SHEET FOR ADDITIONAL SPECIFICATIONS.

NOTES:
 Trusses Manufactured by:
 RIDGWAY ROOF TRUSS
 Analysis Conforms To:
 FBC2010
 TPI 2007
 Girder Common Loading BC
 Span 32- 9- 0
 2 COMPLETE TRUSSES REQUIRED.
 Fasten together in staggered pattern. (1/2" bolts -OR- SDS3 screws -OR- 10d nails as each layer is applied.)
 -----Spacing (In)-----

Rows	Nails	Screws	Bolts
TC	1	12	24
BC	2	12	24
WB	1	8	8

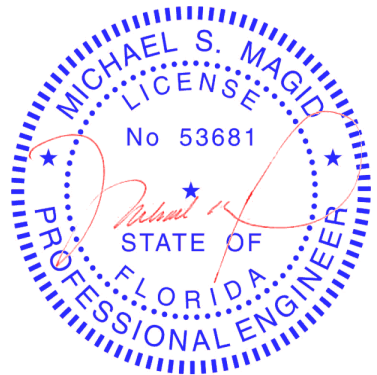

FL Cert. 6634

July 18, 2012

Job 120440	Mark R54	Quan 2	Type MONO	Span 20000	P1-H1 3	Left OH 0	Right OH 0	Engineering T4462874
----------------------	--------------------	-----------	--------------	---------------	------------	--------------	---------------	--------------------------------

18- Rosas- Dreambuilders

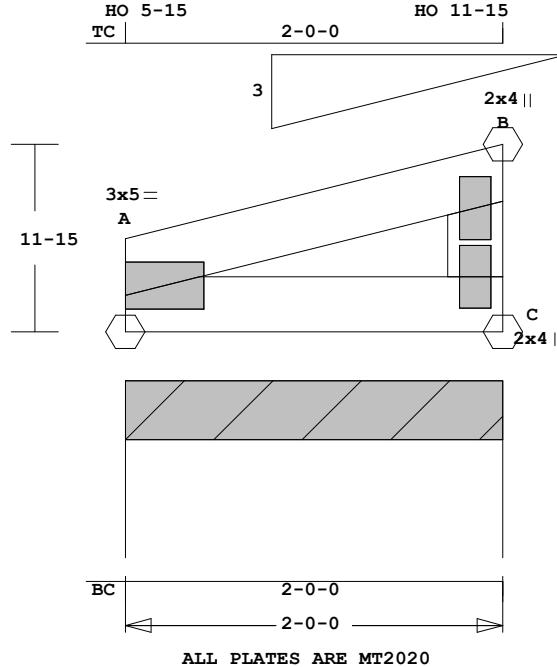

Scale: 0.982" = 1'

MiTek® Online Plus™ APPROX. TRUSS WEIGHT: 8.6 LBS

Online Plus -- Version 30.0.011
RUN DATE: 18-JUL-12

Southern Pine lumber design values are those effective 06-01-12 by SPIB//ALSC UON
CSI -Size- ---Lumber----
TC 0.04 2x 4 SP-#2
BC 0.03 2x 4 SP-#2
WB 0.02 2x 4 SP-#3

Brace truss as follows:
O.C. From To
TC Cont. 0- 0- 0 2- 0- 0
or 24.0" 0- 0- 0 2- 0- 0
BC Cont. 0- 0- 0 2- 0- 0
or 24.0" 0- 0- 0 2- 0- 0

psf-Ld	Dead	Live		
TC	7.0	20.0		
BC	10.0	0.0		
TC+BC	17.0	20.0		
Total	37.0	Spacing 24.0"		
Lumber	Duration Factor	1.25		
Plate	Duration Factor	1.25		
	Fb	Fc	Ft	Emin
TC	1.15	1.10	1.10	1.10
BC	1.10	1.10	1.10	1.10

Total Load Reactions (Lbs)
Jt Down Uplift Horiz-
A 148 35 U 18 R

Jt Brg Size Required
A 24.0" 0"-to- 24"

Plus 18 Wind Load Case(s)
Plus 1 UBC LL Load Case(s)
Plus 1 DL Load Case(s)

Membr	CSI	P	Lbs	Ax1	CSI-Bnd
-----Top Chords-----					
A -B	0.04		27 C	0.00	0.04
-----Bottom Chords-----					
A -C	0.03		3 T	0.00	0.03
-----Webs-----					
C -B	0.02		86 T	WindLd	

TL Defl 0.00" in A -C L/999
LL Defl 0.00" in A -C L/999
Shear // Grain in A -B 0.07

Plates for each ply each face.
Plate - MT20 20 Ga, Gross Area
Plate - MT2H 20 Ga, Gross Area
Plate - MS18 18 Ga, Gross Area
Jt Type Plt Size X Y JSI
A MT20 3.0x 5.0 0.2 Ctr 0.57
B MT20 2.0x 4.0 Ctr Ctr 0.12
C MT20 2.0x 4.0 Ctr Ctr 0.12

REVIEWED BY:
MiTek Industries, Inc.
6904 Parke East Blvd.
Tampa, FL 33610

REFER TO ONLINE PLUS GENERAL
NOTES AND SYMBOLS SHEET FOR
ADDITIONAL SPECIFICATIONS.

NOTES:
Trusses Manufactured by:
RIDGWAY ROOF TRUSS
Analysis Conforms To:
FBC2010
TPI 2007
This truss has been designed for 20.0 psf LL on the B.C. in areas where a rectangle 3- 6- 0 tall by 2- 0- 0 wide will fit between the B.C. and any other member.
Design checked for 10 psf non-concurrent LL on BC.
Truss designed for wind loads in the plane of the truss only. For studs exposed to wind (normal to the face), see Standard Industry Gable End Details as applicable, or consult qualified Building Designer as per ANSI/TPI 1.

Wind Loads - ANSI / ASCE 7-10
Truss is designed as Components and Claddings* for Exterior zone location.
Wind Speed: 130 mph
Risk Category : II
Mean Roof Height: 25-0
Exposure Category: B
Building Type: Enclosed
TC Dead Load: 4.0 psf
BC Dead Load: 6.0 psf
Max comp. force 50 Lbs
Max tens. force 86 Lbs
Connector Plate Fabrication Tolerance = 20%
This truss is designed for a creep factor of 1.5 which is used to calculate total load deflection.

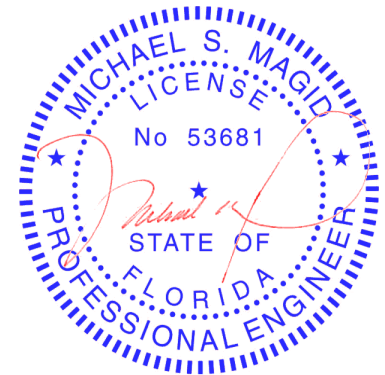

FL Cert. 6634

July 18, 2012

Job 120440	Mark R55	Quan 3	Type MONO	Span 20000	P1-H1 3	Left OH 0	Right OH 0	Engineering T4462875
----------------------	--------------------	-----------	--------------	---------------	------------	--------------	---------------	--------------------------------

18- Rosas- Dreambuilders

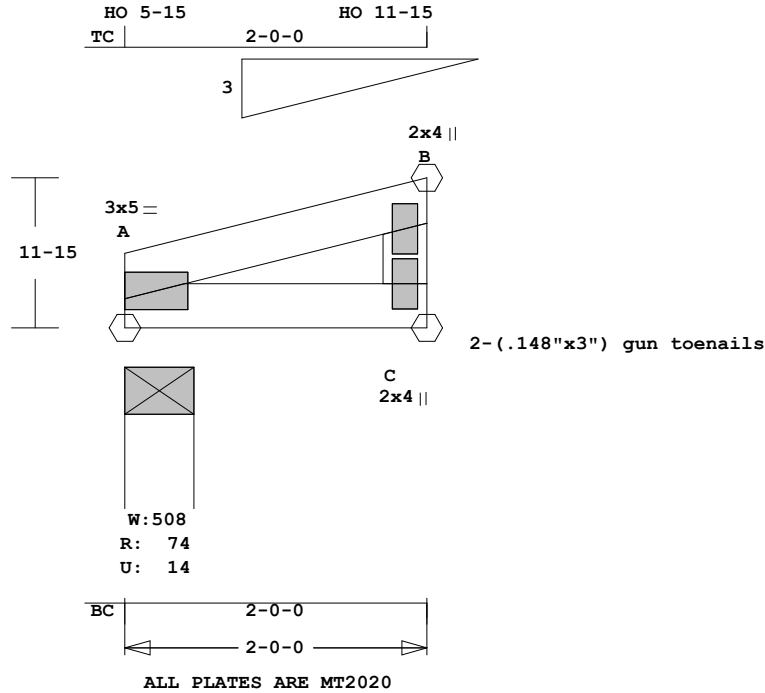

Scale: 0.786" = 1'

MiTek® Online Plus™ APPROX. TRUSS WEIGHT: 8.6 LBS

Online Plus -- Version 30.0.011
RUN DATE: 18-JUL-12

Southern Pine lumber design values are those effective 06-01-12 by SPIB//ALSC UON
CSI -Size- ---Lumber----

TC	0.04	2x 4	SP-#2
BC	0.03	2x 4	SP-#2
WB	0.02	2x 4	SP-#3

Brace truss as follows:

	O.C.	From	To
TC Cont.	0- 0- 0	2- 0- 0	or 24.0"
BC Cont.	0- 0- 0	2- 0- 0	or 24.0"

psf-Ld	Dead	Live		
TC	7.0	20.0		
BC	10.0	0.0		
TC+BC	17.0	20.0		
Total	37.0	Spacing	24.0"	
Lumber	Duration Factor	1.25		
Plate	Duration Factor	1.25		
	Fb	Fc	Ft	Emin
TC	1.15	1.10	1.10	1.10
BC	1.10	1.10	1.10	1.10

Total Load Reactions (Lbs)

Jt	Down	Uplift	Horiz-
A	74	15 U	7 R
C	74	21 U	18 R

Jt	Brg Size	Required
A	5.5"	1.5"
C	3.5"	1.5"

Plus 18 Wind Load Case(s)
Plus 1 UBC LL Load Case(s)
Plus 1 DL Load Case(s)

Membr	CSI	P	Lbs	Axl	CSI-Bnd
-----Top Chords-----					
A -B	0.04		27 C	0.00	0.04
-----Bottom Chords-----					
A -C	0.03		15 T	0.00	0.03

-----Webs-----
C -B 0.02 86 T WindLd

TL Defl 0.00" in A -C L/999
LL Defl 0.00" in A -C L/999
Shear // Grain in A -B 0.07

Plates for each ply each face.
Plate - MT20 20 Ga, Gross Area
Plate - MT2H 20 Ga, Gross Area
Plate - MS18 18 Ga, Gross Area
Jt Type Plt Size X Y JSI
A MT20 3.0x 5.0 0.2 Ctr 0.57
B MT20 2.0x 4.0 Ctr Ctr 0.12
C MT20 2.0x 4.0 Ctr Ctr 0.12

REVIEWED BY:
MiTek Industries, Inc.
6904 Parke East Blvd.
Tampa, FL 33610

REFER TO ONLINE PLUS GENERAL NOTES AND SYMBOLS SHEET FOR ADDITIONAL SPECIFICATIONS.

For proper installation of toe-nails, refer to the 2005 National Design Specification (NDS) for Wood Construction

NOTES:
Trusses Manufactured by:
RIDGWAY ROOF TRUSS
Analysis Conforms To:
FBC2010
TPI 2007

This truss has been designed for 20.0 psf LL on the B.C. in areas where a rectangle 3- 6- 0 tall by 2- 0- 0 wide will fit between the B.C. and any other member. Design checked for 10 psf non-concurrent LL on BC. Wind Loads - ANSI / ASCE 7-10 Truss is designed as

Components and Claddings* for Exterior zone location.
Wind Speed: 130 mph
Risk Category : II
Mean Roof Height: 25-0
Exposure Category: B
Building Type: Enclosed
TC Dead Load: 4.0 psf
BC Dead Load: 6.0 psf
Max comp. force 50 Lbs
Max tens. force 86 Lbs
Connector Plate Fabrication Tolerance = 20%
This truss is designed for a creep factor of 1.5 which is used to calculate total load deflection.

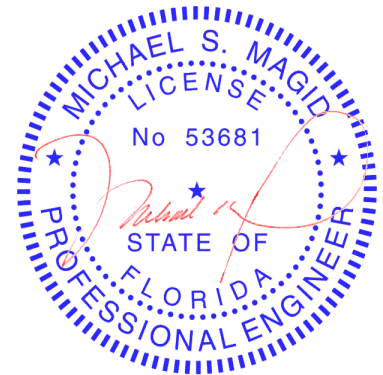

FL Cert. 6634

Job 120440	Mark T1	Quan 16	Type PB	Span 50300	Pl-H1 9	Left OH 0	Right OH 0	Engineering T4462876
----------------------	-------------------	------------	------------	---------------	------------	--------------	---------------	--------------------------------

18- Rosas- Dreambuilders

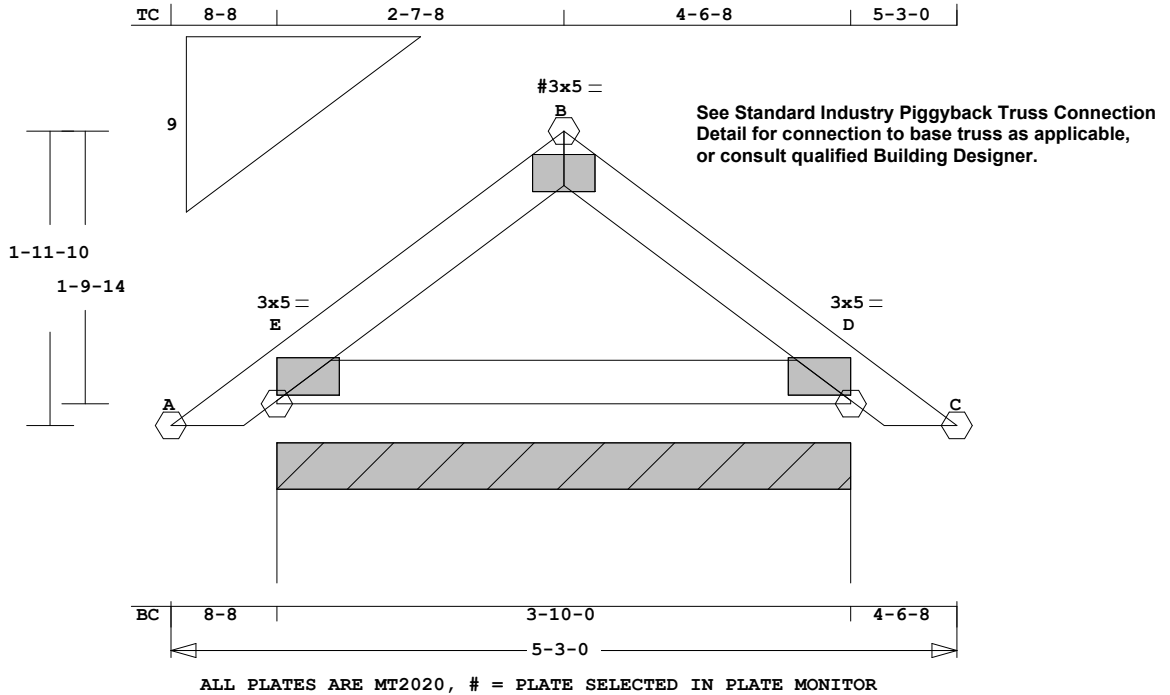

Scale: 0.779" = 1'

MiTek® Online Plus™ APPROX. TRUSS WEIGHT: 19.6 LBS

Online Plus -- Version 30.0.011
RUN DATE: 18-JUL-12

Southern Pine lumber design values are those effective 06-01-12 by SPIB//ALSC UON
CSI -Size- ---Lumber----
TC 0.04 2x 4 SP-#2
BC 0.05 2x 4 SP-#2

Brace truss as follows:

	O.C.	From	To
TC Cont.	0- 0- 0	5- 3- 0	
or	46.0"	0- 0- 0	5- 3- 0
BC Cont.	0- 0- 0	5- 3- 0	
or	46.0"	0- 0- 0	5- 3- 0

psf-Ld	Dead	Live		
TC	7.0	20.0		
BC	10.0	0.0		
TC+BC	17.0	20.0		
Total	37.0	Spacing 24.0"		
Lumber	Duration Factor	1.25		
Plate	Duration Factor	1.25		
	Fb	Fc	Ft	Emin
TC	1.15	1.10	1.10	1.10
BC	1.10	1.10	1.10	1.10

Total Load Reactions (Lbs)
Jt Down Uplift Horiz-
E 285 77 U 27 R

Jt	Brg Size	Required
E	46.0"	0"-to- 46"

Plus 21 Wind Load Case(s)
Plus 1 UBC LL Load Case(s)
Plus 1 DL Load Case(s)

Membr	CSI	P	Lbs	Axl-CSI-Bnd
-----Top Chords-----				
E -B	0.04	88	C	0.00 0.04
B -D	0.04	88	C	0.00 0.04
-----Bottom Chords-----				
E -D	0.05	2	T	0.00 0.05

TL Defl -0.01" in E -D L/999
LL Defl 0.00" in E -D L/999

Shear // Grain in E -D 0.07

Plates for each ply each face.
Plate - MT20 20 Ga, Gross Area
Plate - MT2H 20 Ga, Gross Area
Plate - MS18 20 Ga, Gross Area
Jt Type Plt Size X Y JSI
E MT20 3.0x 5.0 0.3 0.3 0.42
B# MT20 3.0x 5.0 Ctr-1.2 0.33
D MT20 3.0x 5.0-0.3 0.3 0.42

= Plate Monitor used
REVIEWED BY:
MiTek Industries, Inc.
6904 Parke East Blvd.
Tampa, FL 33610

REFER TO ONLINE PLUS GENERAL NOTES AND SYMBOLS SHEET FOR ADDITIONAL SPECIFICATIONS.

NOTES:
Trusses Manufactured by:
RIDGWAY ROOF TRUSS
Analysis Conforms To:
FBC2010
TPI 2007
OH Loading
Soffit psf 2.0
This truss has been designed for 20.0 psf LL on the B.C. in areas where a rectangle 3- 6- 0 tall by 2- 0- 0 wide will fit between the B.C. and any other member.
Design checked for 10 psf non-concurrent LL on BC.
Truss designed for wind loads in the plane of the truss only. For studs exposed to wind (normal to the face), see Standard Industry Gable End Details as applicable, or consult qualified Building Designer as per ANSI/TPI 1.

NOTE: USER MODIFIED PLATES

This design may have plates selected through a plate monitor.
Wind Loads - ANSI / ASCE 7-10
Truss is designed as Components and Claddings* for Exterior zone location.
Wind Speed: 130 mph
Risk Category : II
Mean Roof Height: 25-0
Exposure Category: B
Building Type: Enclosed
TC Dead Load: 4.0 psf
BC Dead Load: 6.0 psf
Max comp. force 88 Lbs
Max tens. force 47 Lbs
Connector Plate Fabrication Tolerance = 20%
This truss is designed for a creep factor of 1.5 which is used to calculate total load deflection.

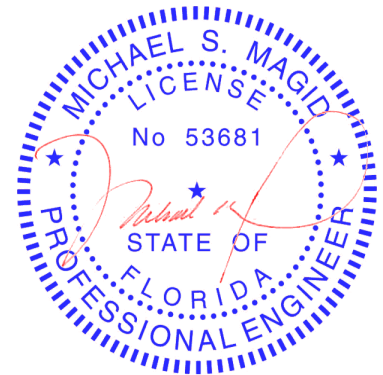

FL Cert. 6634

July 18, 2012

Job 120440	Mark TIA	Quan 1	Type PB	Span 40305	P1-H1 9	Left OH 0	Right OH 0	Engineering T4462877
----------------------	--------------------	-----------	------------	---------------	------------	--------------	---------------	--------------------------------

18- Rosas- Dreambuilders

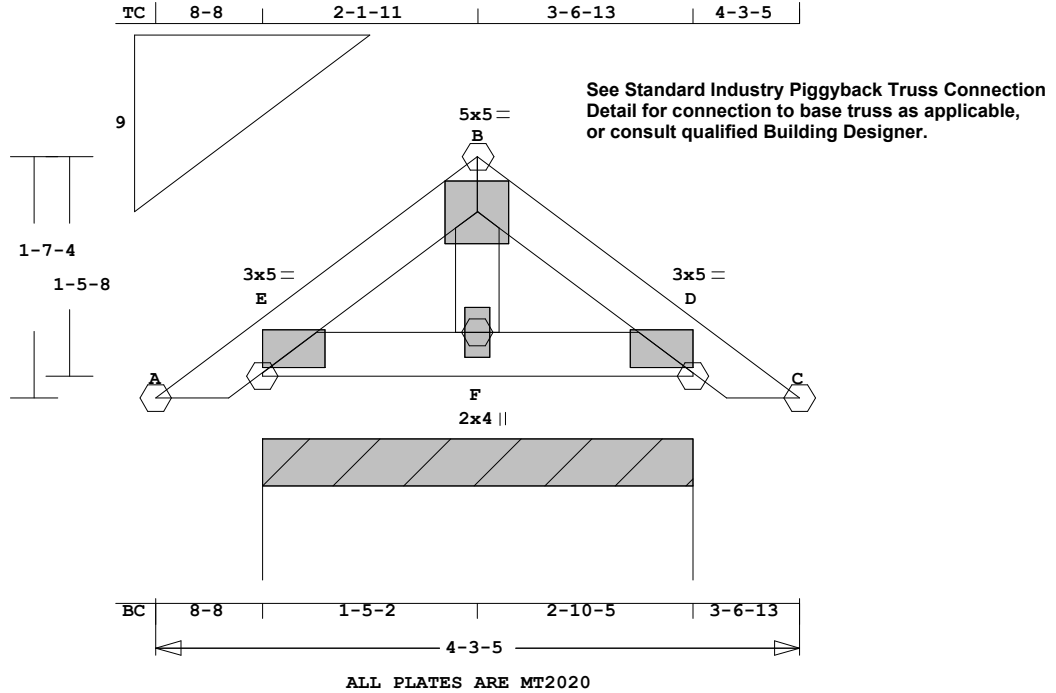

Scale: 0.784" = 1'

MiTek® Online Plus™ APPROX. TRUSS WEIGHT: 17.0 LBS

Online Plus -- Version 30.0.011
RUN DATE: 18-JUL-12

Southern Pine lumber design values are those effective 06-01-12 by SPIB//ALSC UON

	CSI	-Size-	---	Lumber	----
TC	0.01	2x 4	SP-#2		
BC	0.00	2x 4	SP-#2		
WB	0.00	2x 4	SP-#3		

Brace truss as follows:

	O.C.	From	To
TC	Cont.	0- 0- 0	4- 3- 5
or	34.3"	0- 0- 0	4- 3- 5
BC	Cont.	0- 0- 0	4- 3- 5
or	34.3"	0- 0- 0	4- 3- 5

psf-Ld	Dead	Live		
TC	7.0	20.0		
BC	10.0	0.0		
TC+BC	17.0	20.0		
Total	37.0	Spacing 24.0"		
Lumber	Duration Factor	1.25		
Plate	Duration Factor	1.25		
	Fb	Fc	Ft	Emin
TC	1.15	1.10	1.10	1.10
BC	1.10	1.10	1.10	1.10

Total Load Reactions (Lbs)

Jt	Down	Uplift	Horiz-
E	213	60 U	19 R

Jt	Brg Size	Required
E	34.3"	0"-to- 34"

Plus 21 Wind Load Case(s)
Plus 1 UBC LL Load Case(s)
Plus 1 DL Load Case(s)

Membr	CSI	P	Lbs	Axl	CSI	Bnd
-----Top Chords-----						
E -B	0.01		39 C	0.00	0.01	
B -D	0.01		39 C	0.00	0.01	
-----Bottom Chords-----						
E -F	0.00		0 T			
F -D	0.00		0 T			
-----Webs-----						

F -B 0.00 26 C

TL Defl 0.00" in F -D L/999
LL Defl 0.00" in F -D L/999
Shear // Grain in E -B 0.02

Plates for each ply each face.
Plate - MT20 20 Ga, Gross Area
Plate - MT2H 20 Ga, Gross Area
Plate - MS18 18 Ga, Gross Area
Jt Type Plt Size X Y JSI
E MT20 3.0x 5.0 0.3 0.3 0.42
B MT20 5.0x 5.0 Ctr Ctr 0.33
D MT20 3.0x 5.0-0.3 0.3 0.42
F MT20 2.0x 4.0 Ctr Ctr 0.12

REVIEWED BY:
MiTek Industries, Inc.
6904 Parke East Blvd.
Tampa, FL 33610

REFER TO ONLINE PLUS GENERAL NOTES AND SYMBOLS SHEET FOR ADDITIONAL SPECIFICATIONS.

NOTES:

Trusses Manufactured by:
RIDGWAY ROOF TRUSS
Analysis Conforms To:
FBC2010
TPI 2007
OH Loading
Soffit psf 2.0

This truss has been designed for 20.0 psf LL on the B.C. in areas where a rectangle 3- 6- 0 tall by 2- 0- 0 wide will fit between the B.C. and any other member.

Design checked for 10 psf non-concurrent LL on BC.

Truss designed for wind loads in the plane of the truss only. For studs exposed to wind (normal to the face), see Standard Industry Gable End Details as applicable,

or consult qualified Building Designer as per ANSI/TPI 1.
Wind Loads - ANSI / ASCE 7-10
Truss is designed as Components and Claddings* for Exterior zone location.
Wind Speed: 130 mph
Risk Category : II
Mean Roof Height: 25-0
Exposure Category: B
Building Type: Enclosed
TC Dead Load: 4.0 psf
BC Dead Load: 6.0 psf
Max comp. force 39 Lbs
Max tens. force 25 Lbs
Connector Plate Fabrication Tolerance = 20%
This truss is designed for a creep factor of 1.5 which is used to calculate total load deflection.

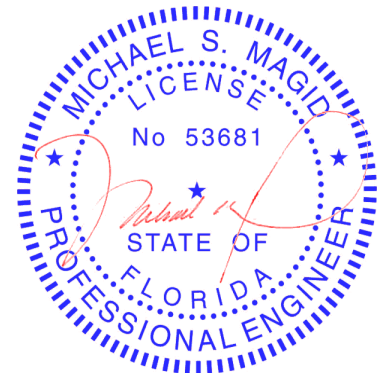

FL Cert. 6634

July 18, 2012

Job 120440	Mark T1B	Quan 1	Type PB	Span 40903	P1-H1 9	Left OH 0	Right OH 0	Engineering T4462878
----------------------	--------------------	-----------	------------	---------------	------------	--------------	---------------	-------------------------

18- Rosas- Dreambuilders

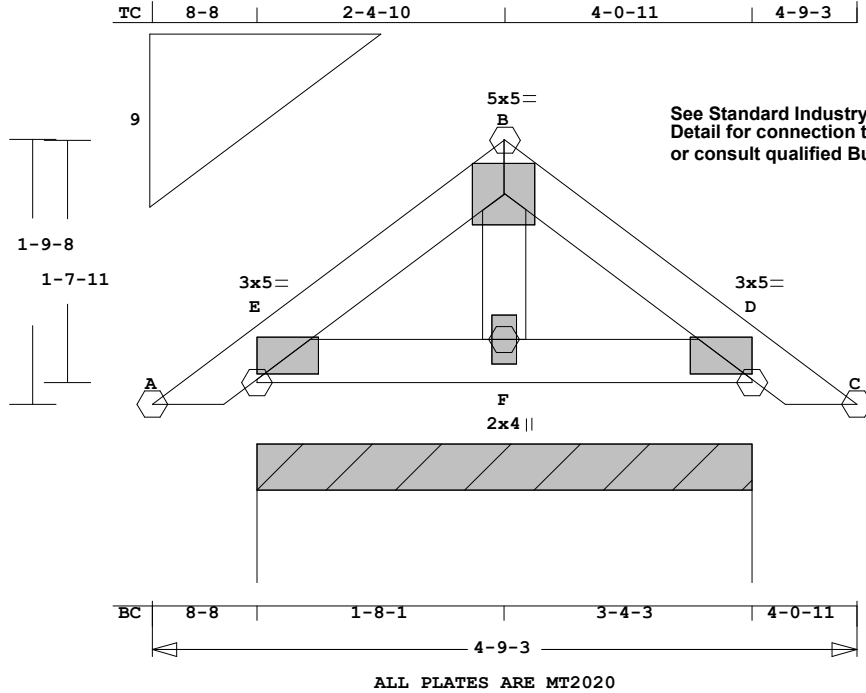

See Standard Industry Piggyback Truss Connection Detail for connection to base truss as applicable, or consult qualified Building Designer.

Scale: 0.770" = 1'

MiTek® Online Plus™ APPROX. TRUSS WEIGHT: 19.4 LBS

Online Plus -- Version 30.0.011
RUN DATE: 18-JUL-12

Southern Pine lumber design values are those effective 06-01-12 by SPIB//ALSC UON

TC	0.01	2x 4	SP-#2
BC	0.01	2x 4	SP-#2
WB	0.00	2x 4	SP-#3

Brace truss as follows:

O.C.	From	To
TC Cont.	0- 0- 0	4- 9- 3
or 40.2"	0- 0- 0	4- 9- 3
BC Cont.	0- 0- 0	4- 9- 3
or 40.2"	0- 0- 0	4- 9- 3

psf-Ld	Dead	Live
TC	7.0	20.0
BC	10.0	0.0
TC+BC	17.0	20.0
Total	37.0	Spacing 24.0"
Lumber	Duration Factor	1.25
Plate	Duration Factor	1.25
	Fb	Fc Ft Emin
TC	1.15	1.10 1.10 1.10
BC	1.10	1.10 1.10 1.10

Jt	Down	Uplift	Horiz-
E	250	68 U	23 R

Jt	Brg Size	Required
E	40.2"	0"-to- 40"

Plus 21 Wind Load Case(s)
Plus 1 UBC LL Load Case(s)
Plus 1 DL Load Case(s)

Membr	CSI	P	Lbs	Axl	CSI-Bnd
-----Top Chords-----					
E -B	0.01	51	C	0.00	0.01
B -D	0.01	51	C	0.00	0.01
-----Bottom Chords-----					
E -F	0.01	0	T	0.00	0.01
F -D	0.01	0	T	0.00	0.01
-----Webs-----					

F -B 0.00 27 C

TL Defl 0.00" in F -D L/999
LL Defl 0.00" in F -D L/999
Shear // Grain in E -B 0.03

Plates for each ply each face.
Plate - MT20 20 Ga, Gross Area
Plate - MT2H 20 Ga, Gross Area
Plate - MS18 18 Ga, Gross Area
Jt Type Plt Size X Y JSI
E MT20 3.0x 5.0 0.3 0.3 0.42
B MT20 5.0x 5.0 Ctr Ctr 0.33
D MT20 3.0x 5.0-0.3 0.3 0.42
F MT20 2.0x 4.0 Ctr Ctr 0.12

REVIEWED BY:
MiTek Industries, Inc.
6904 Parke East Blvd.
Tampa, FL 33610

REFER TO ONLINE PLUS GENERAL NOTES AND SYMBOLS SHEET FOR ADDITIONAL SPECIFICATIONS.

NOTES:

Trusses Manufactured by:
RIDGWAY ROOF TRUSS
Analysis Conforms To:
FBC2010
TPI 2007
OH Loading
Soffit psf 2.0

This truss has been designed for 20.0 psf LL on the B.C. in areas where a rectangle 3- 6- 0 tall by 2- 0- 0 wide will fit between the B.C. and any other member.

Design checked for 10 psf non-concurrent LL on BC.

Truss designed for wind loads in the plane of the truss only. For studs exposed to wind (normal to the face), see Standard Industry Gable End Details as applicable,

or consult qualified Building Designer as per ANSI/TPI 1.
Wind Loads - ANSI / ASCE 7-10
Truss is designed as Components and Claddings* for Exterior zone location.
Wind Speed: 130 mph
Risk Category : II
Mean Roof Height: 25-0
Exposure Category: B
Building Type: Enclosed
TC Dead Load: 4.0 psf
BC Dead Load: 6.0 psf
Max comp. force 51 Lbs
Max tens. force 33 Lbs
Connector Plate Fabrication Tolerance = 20%
This truss is designed for a creep factor of 1.5 which is used to calculate total load deflection.

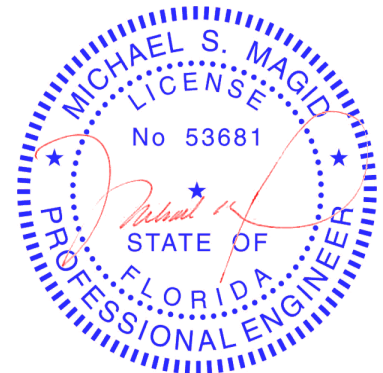

FL Cert. 6634

July 18, 2012

Job 120440	Mark T2	Quan 2	Type PB	Span 80700	P1-H1 9	Left OH 0	Right OH 0	Engineering T4462879
----------------------	-------------------	-----------	------------	---------------	------------	--------------	---------------	--------------------------------

18- Rosas- Dreambuilders

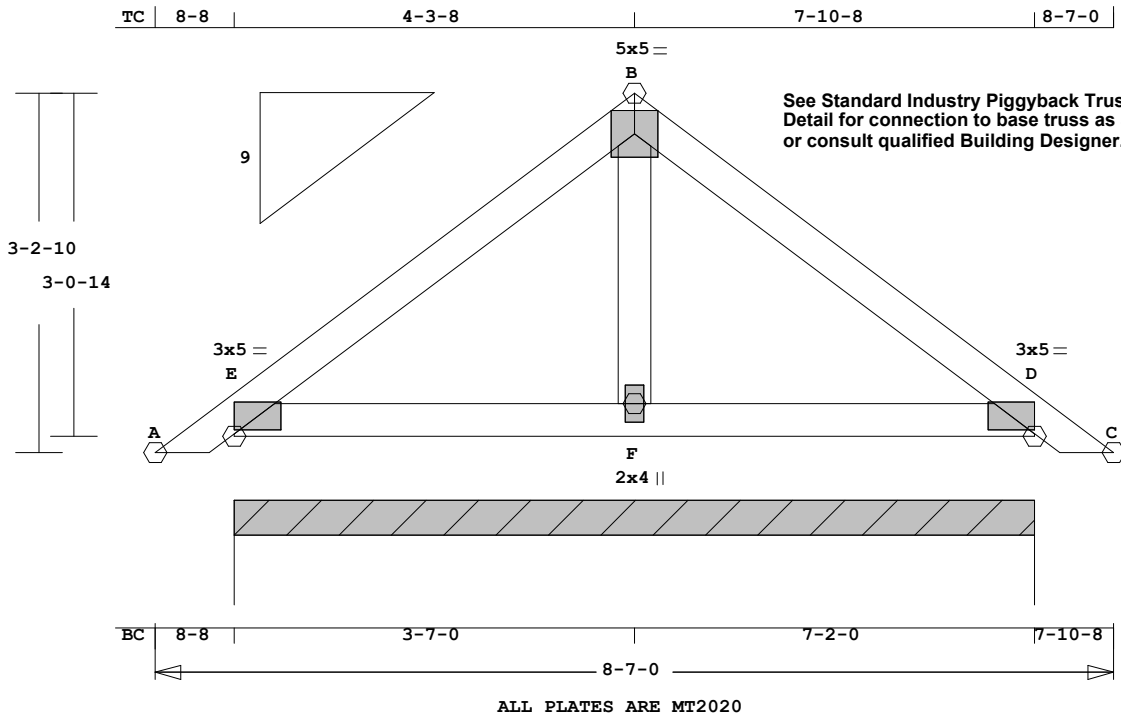

See Standard Industry Piggyback Truss Connection Detail for connection to base truss as applicable, or consult qualified Building Designer.

Scale: 0.581" = 1'

MiTek® Online Plus™ APPROX. TRUSS WEIGHT: 38.4 LBS

Online Plus -- Version 30.0.011
RUN DATE: 18-JUL-12

Southern Pine lumber design values are those effective 06-01-12 by SPIB//ALSC UON

CSI	-Size-	---Lumber---
TC	0.09	2x 4 SP-#2
BC	0.08	2x 4 SP-#2
WB	0.01	2x 4 SP-#3

Brace truss as follows:

O.C.	From	To
TC Cont.	0- 0- 0	8- 7- 0
or	48.0"	0- 0- 0 8- 7- 0
BC Cont.	0- 0- 0	8- 7- 0
or	86.0"	0- 0- 0 8- 7- 0

psf-Ld	Dead	Live
TC	7.0	20.0
BC	10.0	0.0
TC+BC	17.0	20.0
Total	37.0	Spacing 24.0"
Lumber	Duration Factor	1.25
Plate	Duration Factor	1.25
	Fb	Fc Ft Emin
TC	1.15	1.10 1.10 1.10
BC	1.10	1.10 1.10 1.10

Total Load Reactions (Lbs)			
Jt	Down	Uplift	Horiz-
E	532	136 U	52 R

Jt	Brg Size	Required
E	86.0"	0"-to- 86"

Plus 21 Wind Load Case(s)
Plus 1 UBC LL Load Case(s)
Plus 1 DL Load Case(s)

Membr	CSI	P	Lbs	Axl-CSI-Bnd
-----Top Chords-----				
E -B	0.09	176	C	0.00 0.09
B -D	0.09	176	C	0.00 0.09
-----Bottom Chords-----				
E -F	0.08	1	T	0.00 0.08
F -D	0.08	1	T	0.00 0.08
-----Webs-----				

F -B 0.01 49 T

TL Defl 0.00" in E -F L/999
LL Defl 0.00" in E -F L/999
Shear // Grain in E -B 0.09

Plates for each ply each face.
Plate - MT20 20 Ga, Gross Area
Plate - MT2H 20 Ga, Gross Area
Plate - MS18 18 Ga, Gross Area
Jt Type Plt Size X Y JSI
E MT20 3.0x 5.0 0.3 0.3 0.42
B MT20 5.0x 5.0 Ctr Ctr 0.33
D MT20 3.0x 5.0-0.3 0.3 0.42
F MT20 2.0x 4.0 Ctr Ctr 0.12

REVIEWED BY:
MiTek Industries, Inc.
6904 Parke East Blvd.
Tampa, FL 33610

REFER TO ONLINE PLUS GENERAL NOTES AND SYMBOLS SHEET FOR ADDITIONAL SPECIFICATIONS.

NOTES:

Trusses Manufactured by:
RIDGWAY ROOF TRUSS
Analysis Conforms To:
FBC2010
TPI 2007
OH Loading
Soffit psf 2.0

This truss has been designed for 20.0 psf LL on the B.C. in areas where a rectangle 3- 6- 0 tall by 2- 0- 0 wide will fit between the B.C. and any other member.

Design checked for 10 psf non-concurrent LL on BC.

Truss designed for wind loads in the plane of the truss only. For studs exposed to wind (normal to the face), see Standard Industry Gable End Details as applicable,

or consult qualified Building Designer as per ANSI/TPI 1.
Wind Loads - ANSI / ASCE 7-10
Truss is designed as Components and Claddings* for Exterior zone location.
Wind Speed: 130 mph
Risk Category : II
Mean Roof Height: 25-0
Exposure Category: B
Building Type: Enclosed
TC Dead Load: 4.0 psf
BC Dead Load: 6.0 psf
Max comp. force 176 Lbs
Max tens. force 109 Lbs
Connector Plate Fabrication Tolerance = 20%
This truss is designed for a creep factor of 1.5 which is used to calculate total load deflection.

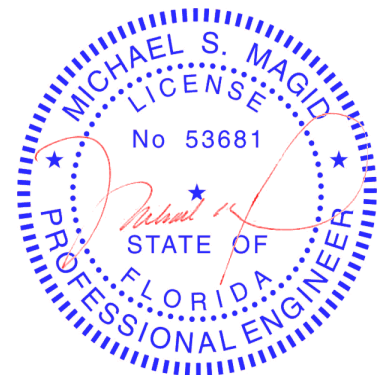

FL Cert. 6634

July 18, 2012

Job 120440	Mark T2A	Quan 1	Type PB	Span 70704	P1-H1 9	Left OH 0	Right OH 0	Engineering T4462880
----------------------	--------------------	-----------	------------	---------------	------------	--------------	---------------	--------------------------------

18- Rosas- Dreambuilders

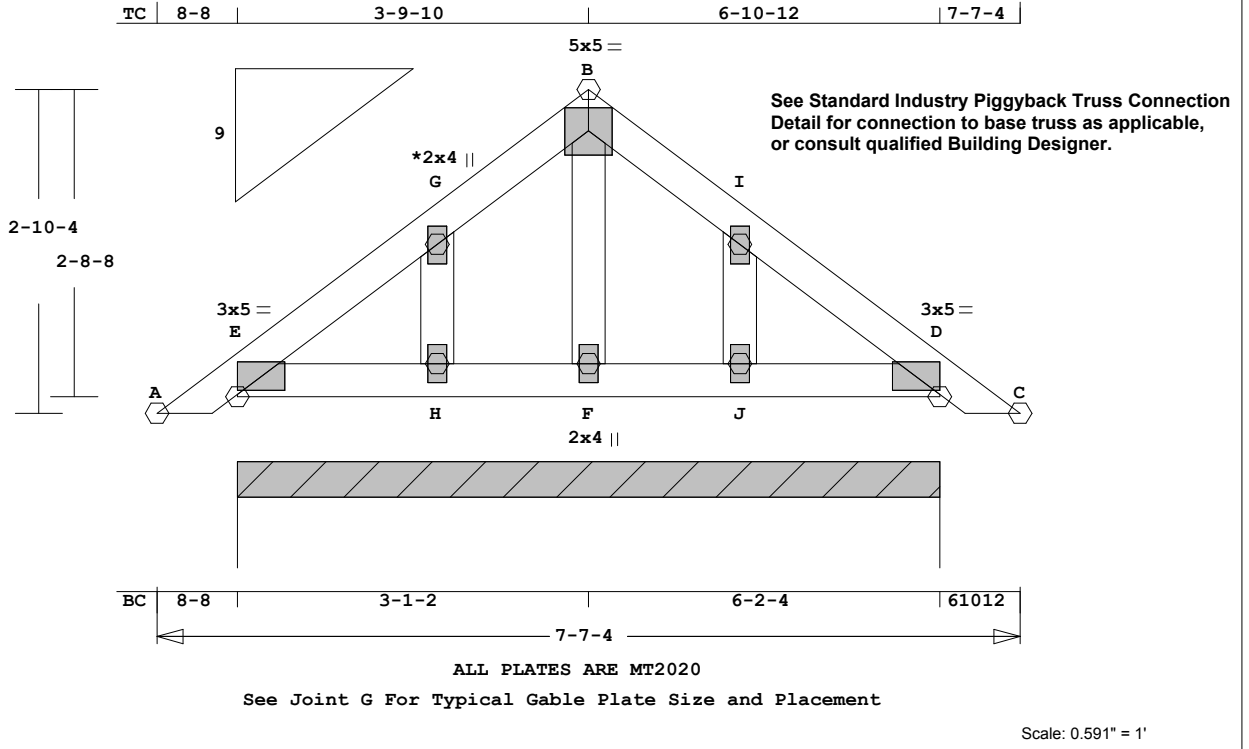

Online Plus -- Version 30.0.011
RUN DATE: 18-JUL-12

Southern Pine lumber design values are those effective 06-01-12 by SPIB//ALSC UON
CSI -Size- ---Lumber---

TC	0.01	2x 4	SP-#2
BC	0.01	2x 4	SP-#2
WB	0.00	2x 4	SP-#3
GW	0.02	2x 4	SP-#3

Brace truss as follows:

O.C.	From	To
TC Cont.	0- 0- 0	7- 7- 4
or 48.0"	0- 0- 0	7- 7- 4
BC Cont.	0- 0- 0	7- 7- 4
or 74.2"	0- 0- 0	7- 7- 4

psf-Ld	Dead	Live
TC	7.0	20.0
BC	10.0	0.0
TC+BC	17.0	20.0
Total	37.0	Spacing 24.0"
Lumber Duration Factor	1.25	
Plate Duration Factor	1.25	
	Fb	Fc Ft Emin
TC	1.15	1.10 1.10 1.10
BC	1.10	1.10 1.10 1.10

Total Load Reactions (Lbs)

Jt	Down	Uplift	Horiz-
E	460	119 U	45 R

Jt	Brg Size	Required
E	74.2"	0"-to- 74"

Plus 21 Wind Load Case(s)
Plus 1 UBC LL Load Case(s)
Plus 1 DL Load Case(s)

Membr	CSI	P	Lbs	Axl	CSI-Bnd
-----Top Chords-----					
E -G	0.01	42	C	0.00	0.01
G -B	0.01	59	C	0.00	0.01
B -I	0.01	59	C	0.00	0.01
I -D	0.01	42	C	0.00	0.01
-----Bottom Chords-----					
E -H	0.01	1	T	0.00	0.01
H -F	0.01	0	T	0.00	0.01

MiTek® Online Plus™ APPROX. TRUSS WEIGHT: 37.9 LBS

F -J	0.01	0	T	0.00	0.01
J -D	0.01	1	T	0.00	0.01
-----Webs-----					
F -B	0.00	24	C		
-----Gable Webs-----					
H -G	0.02	100	C		
J -I	0.02	100	C		
TL Defl	0.00"	in J -D L/999			
LL Defl	0.00"	in J -D L/999			
Shear // Grain	in E -G 0.04				

Plates for each ply each face.

Plate - MT20 20 Ga, Gross Area

Plate - MT2H 20 Ga, Gross Area

Plate - MS18 18 Ga, Gross Area

Jt Type Plt Size X Y JSI

E	MT20	3.0x	5.0	0.3	0.3	0.42
G	MT20	2.0x	4.0	Ctr	Ctr	0.00
B	MT20	5.0x	5.0	Ctr	Ctr	0.33
I	MT20	2.0x	4.0	Ctr	Ctr	0.00
D	MT20	3.0x	5.0	0.3	0.3	0.42
H	MT20	2.0x	4.0	Ctr	Ctr	0.00
F	MT20	2.0x	4.0	Ctr	Ctr	0.12
J	MT20	2.0x	4.0	Ctr	Ctr	0.00

REVIEWED BY:
MiTek Industries, Inc.
6904 Parke East Blvd.
Tampa, FL 33610

REFER TO ONLINE PLUS GENERAL NOTES AND SYMBOLS SHEET FOR ADDITIONAL SPECIFICATIONS.

NOTES:

Trusses Manufactured by:
RIDGWAY ROOF TRUSS

Analysis Conforms To:
FBC2010
TPI 2007

OH Loading
Soffit psf 2.0

Design checked for 10 psf non-concurrent LL on BC.

Truss designed for wind loads in the plane of the truss only. For studs exposed to wind (normal to the face), see Standard Industry Gable

See Standard Industry Piggyback Truss Connection Detail for connection to base truss as applicable, or consult qualified Building Designer.

End Details as applicable, or consult qualified Building Designer as per ANSI/TPI 1.

Wind Loads - ANSI / ASCE 7-10

Truss is designed as Components and Claddings* for Exterior zone location.

Wind Speed: 130 mph

Risk Category : II

Mean Roof Height: 25-0

Exposure Category: B

Building Type: Enclosed

TC Dead Load: 4.0 psf

BC Dead Load: 6.0 psf

Max comp. force 100 Lbs

Max tens. force 83 Lbs

Connector Plate Fabrication Tolerance = 20%

This truss is designed for a creep factor of 1.5 which is used to calculate total load deflection.

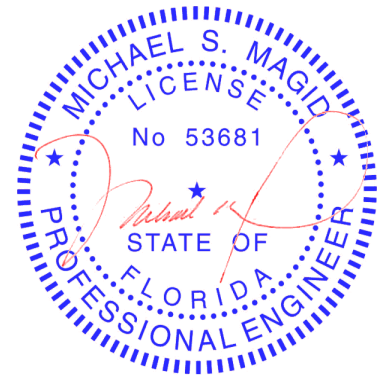

FL Cert. 6634

Job 120440	Mark VI	Quan 3	Type VL	Span 30904	P1-H1 9	Left OH 0	Right OH 0	Engineering T4462881
----------------------	-------------------	-----------	------------	---------------	------------	--------------	---------------	--------------------------------

18- Rosas- Dreambuilders

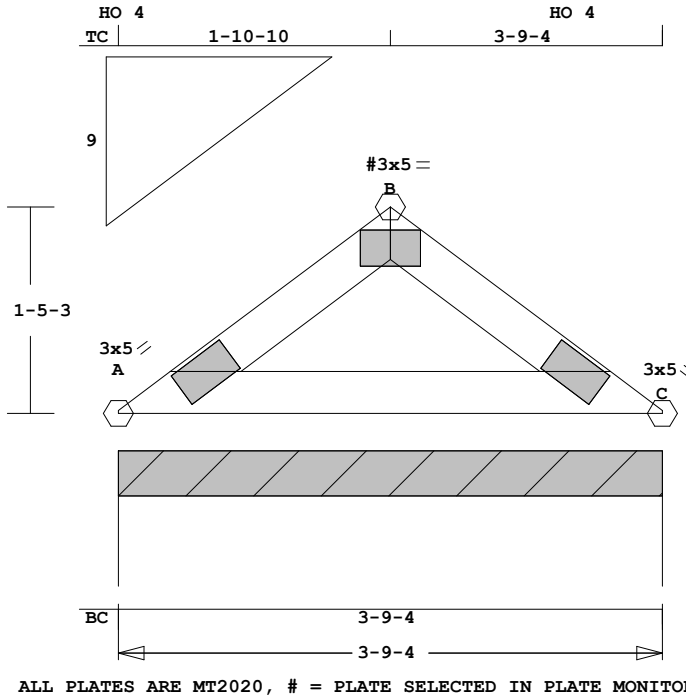

Scale: 0.751" = 1'

MiTek® Online Plus™ APPROX. TRUSS WEIGHT: 14.3 LBS

Online Plus -- Version 30.0.011
RUN DATE: 18-JUL-12

Southern Pine lumber design values are those effective 06-01-12 by SPIB//ALSC UON
CSI -Size- ----Lumber----
TC 0.02 2x 4 SP-#2
BC 0.03 2x 4 SP-#2

Brace truss as follows:
O.C. From To
TC Cont. 0- 0- 0 3- 9- 4
or 45.2" 0- 0- 0 3- 9- 4
BC Cont. 0- 0- 0 3- 9- 4
or 45.2" 0- 0- 0 3- 9- 4

psf-Ld	Dead	Live		
TC	7.0	20.0		
BC	10.0	0.0		
TC+BC	17.0	20.0		
Total	37.0	Spacing 24.0"		
Lumber	Duration Factor	1.25		
Plate	Duration Factor	1.25		
	Fb	Fc	Ft	Emin
TC	1.15	1.10	1.10	1.10
BC	1.10	1.10	1.10	1.10

Total Load Reactions (Lbs)
Jt Down Uplift Horiz-
A 218 52 U 21 R

Jt	Brg Size	Required
A	45.2"	0"-to- 45"

Plus 21 Wind Load Case(s)
Plus 1 UBC LL Load Case(s)
Plus 1 DL Load Case(s)

Membr CSI P Lbs Axl-CSI-Bnd
-----Top Chords-----

A -B	0.00	67	C
B -C	0.02	60	C 0.00 0.02
-----Bottom Chords-----			
A -C	0.03	0	T 0.00 0.03
TL Defl	0.00"	in A -C	L/999
LL Defl	0.00"	in A -C	L/999
Shear // Grain	in A -C	0.05	
Plates for each ply each face.			
Plate - MT20	20 Ga,	Gross Area	
Plate - MT2H	20 Ga,	Gross Area	
Plate - MS18	20 Ga,	Gross Area	
Jt Type	Plt Size	X Y JSI	
A	MT20	3.0x 5.0 Ctr Ctr	0.43
B#	MT20	3.0x 5.0 Ctr-1.2	0.33
C	MT20	3.0x 5.0 Ctr Ctr	0.43

= Plate Monitor used
REVIEWED BY:
MiTek Industries, Inc.
6904 Parke East Blvd.
Tampa, FL 33610

REFER TO ONLINE PLUS GENERAL NOTES AND SYMBOLS SHEET FOR ADDITIONAL SPECIFICATIONS.

NOTES:
Trusses Manufactured by:
RIDGWAY ROOF TRUSS
Analysis Conforms To:
FBC2010
TPI 2007
Design checked for 10 psf non-concurrent LL on BC.
NOTE: USER MODIFIED PLATES
This design may have plates selected through a plate monitor.
Wind Loads - ANSI / ASCE 7-10

Truss is designed as Components and Claddings* for Exterior zone location.
Wind Speed: 130 mph
Risk Category : II
Mean Roof Height: 25-0
Exposure Category: B
Building Type: Enclosed
TC Dead Load: 4.0 psf
BC Dead Load: 6.0 psf
Max comp. force 67 Lbs
Max tens. force 37 Lbs
Connector Plate Fabrication Tolerance = 20%
This truss is designed for a creep factor of 1.5 which is used to calculate total load deflection.

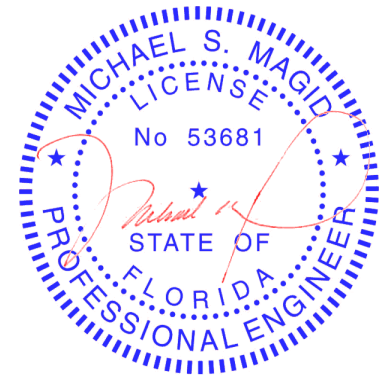

FL Cert. 6634

Job 120440	Mark V2	Quan 3	Type VL	Span 70904	P1-H1 9	Left OH 0	Right OH 0	Engineering T4462882
----------------------	-------------------	-----------	------------	---------------	------------	--------------	---------------	-------------------------

18- Rosas- Dreambuilders

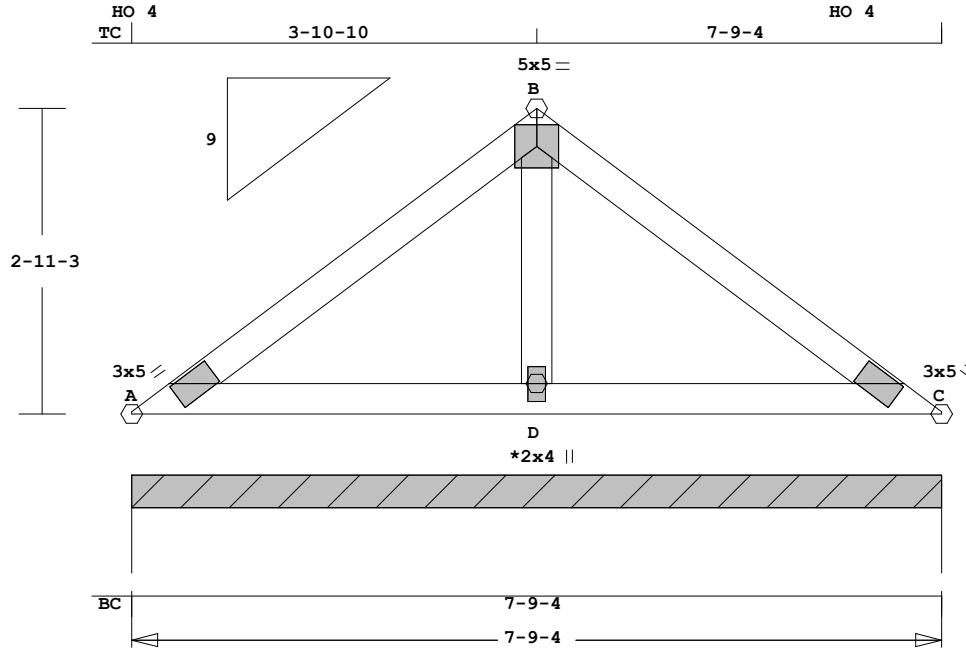

ALL PLATES ARE MT2020

See Joint D For Typical Gable Plate Size and Placement

Scale: 0.543" = 1'

Online Plus -- Version 30.0.011
RUN DATE: 18-JUL-12

Southern Pine lumber design
values are those effective
06-01-12 by SPIB//ALSC UON

CSI -Size- ---Lumber---
TC 0.11 2x 4 SP-#2
BC 0.08 2x 4 SP-#2
GW 0.01 2x 4 SP-#3

Brace truss as follows:
O.C. From To
TC Cont. 0- 0- 0 7- 9- 4
or 48.0" 0- 0- 0 7- 9- 4
BC Cont. 0- 0- 0 7- 9- 4
or 69.2" 0- 0- 0 7- 9- 4

psf-Ld	Dead	Live		
TC	7.0	20.0		
BC	10.0	0.0		
TC+BC	17.0	20.0		
Total	37.0	Spacing 24.0"		
Lumber	Duration Factor	1.25		
Plate	Duration Factor	1.25		
	Fb	Fc	Ft	Emin
TC	1.15	1.10	1.10	1.10
BC	1.10	1.10	1.10	1.10

Total Load Reactions (Lbs)
Jt Down Uplift Horiz-
A 514 123 U 51 R

Jt Brg Size Required
A 93.2" 0"-to- 93"

Plus 21 Wind Load Case(s)
Plus 1 UBC LL Load Case(s)
Plus 1 DL Load Case(s)

Membr CSI P Lbs Ax1-CSI-Bnd

MiTek® Online Plus™ APPROX. TRUSS WEIGHT: 35.6 LBS

-----Top Chords-----
A -B 0.07 111 C 0.00 0.07
B -C 0.11 107 C 0.00 0.11
-----Bottom Chords-----
A -D 0.08 0 T 0.00 0.08
D -C 0.08 1 C 0.00 0.08
-----Gable Webs-----
D -B 0.01 79 C

TL Defl -0.01" in D -C L/999
LL Defl 0.00" in D -C L/999
Shear // Grain in B -C 0.09

Plates for each ply each face.
Plate - MT20 20 Ga, Gross Area
Plate - MT2H 20 Ga, Gross Area
Plate - MS18 18 Ga, Gross Area
Jt Type Plt Size X Y JSI
A MT20 3.0x 5.0 Ctr Ctr 0.43
B MT20 5.0x 5.0 Ctr Ctr 0.33
C MT20 3.0x 5.0 Ctr Ctr 0.43
D MT20 2.0x 4.0 Ctr Ctr 0.00

REVIEWED BY:
MiTek Industries, Inc.
6904 Parke East Blvd.
Tampa, FL 33610

REFER TO ONLINE PLUS GENERAL
NOTES AND SYMBOLS SHEET FOR
ADDITIONAL SPECIFICATIONS.

NOTES:
Trusses Manufactured by:
RIDGWAY ROOF TRUSS

Analysis Conforms To:
FBC2010
TPI 2007
Design checked for 10 psf non-
concurrent LL on BC.
Wind Loads - ANSI / ASCE 7-10

Truss is designed as
Components and Claddings*
for Exterior zone location.
Wind Speed: 130 mph
Risk Category : II
Mean Roof Height: 25-0
Exposure Category: B
Building Type: Enclosed
TC Dead Load: 4.0 psf
BC Dead Load: 6.0 psf
Max comp. force 111 Lbs
Max tens. force 79 Lbs
Connector Plate Fabrication
Tolerance = 20%
This truss is designed for a
creep factor of 1.5 which
is used to calculate total
load deflection.

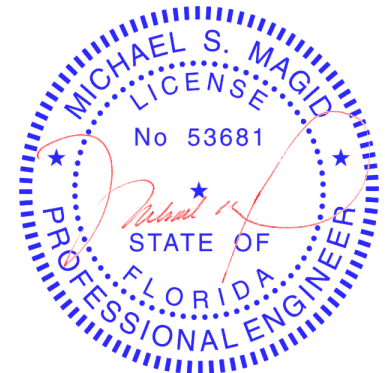

FL Cert. 6634

Job 120440	Mark V3	Quan 3	Type VL	Span 110904	Pl-H1 9	Left OH 0	Right OH 0	Engineering T4462883
----------------------	-------------------	-----------	------------	----------------	------------	--------------	---------------	--------------------------------

18- Rosas- Dreambuilders

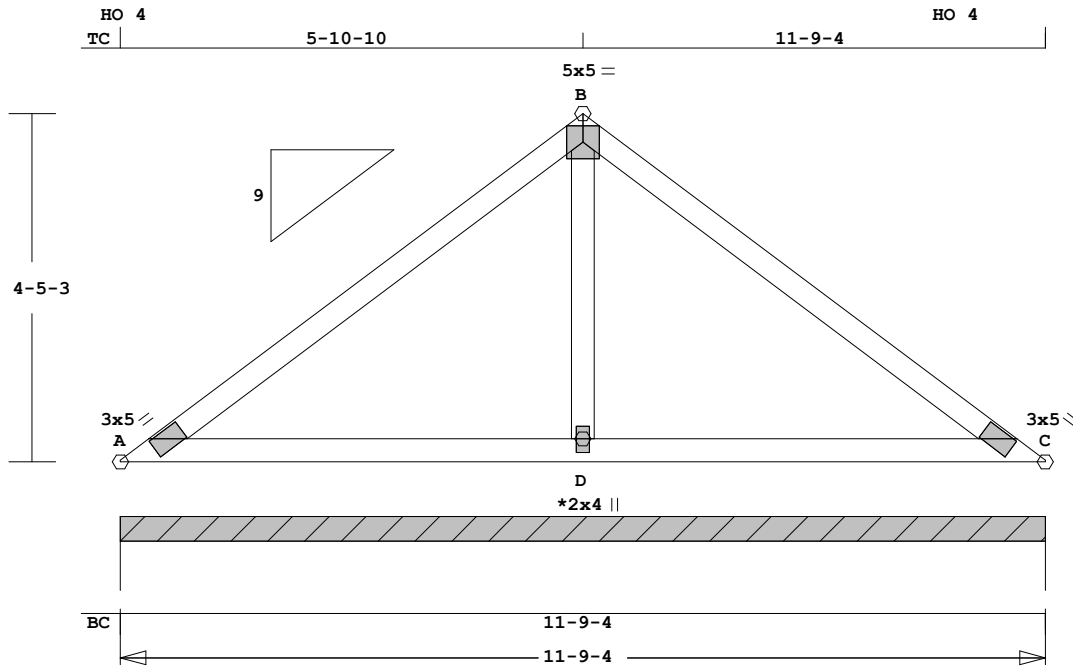

ALL PLATES ARE MT2020

See Joint D For Typical Gable Plate Size and Placement

Scale: 0.409" = 1'

MiTek® Online Plus™ APPROX. TRUSS WEIGHT: 55.5 LBS

Online Plus -- Version 30.0.011
RUN DATE: 18-JUL-12

Southern Pine lumber design
values are those effective
06-01-12 by SPIB//ALSC UON

CSI -Size- ---Lumber---
TC 0.29 2x 4 SP-#2
BC 0.22 2x 4 SP-#2
GW 0.03 2x 4 SP-#3

Brace truss as follows:
O.C. From To
TC Cont. 0- 0- 0 11- 9- 4
or 48.0" 0- 0- 0 11- 9- 4
BC Cont. 0- 0- 0 11- 9- 4
or 72.0" 0- 0- 0 11- 9- 4

psf-Ld	Dead	Live		
TC	7.0	20.0		
BC	10.0	0.0		
TC+BC	17.0	20.0		
Total	37.0		Spacing	24.0"
Lumber	Duration	Factor		1.25
Plate	Duration	Factor		1.25
	Fb	Fc	Ft	Emin
TC	1.15	1.10	1.10	1.10
BC	1.10	1.10	1.10	1.10

Total Load Reactions (Lbs)
Jt Down Uplift Horiz-
A 810 194 U 82 R

Jt Brg Size Required
A 141.2" 0"-to- 141"

Plus 21 Wind Load Case(s)
Plus 1 UBC LL Load Case(s)
Plus 1 DL Load Case(s)

Membr CSI P Lbs Ax1-CSt-Bnd

-----Top Chords-----
A -B 0.22 246 C 0.00 0.22
B -C 0.29 244 C 0.00 0.29
-----Bottom Chords-----
A -D 0.22 0 T 0.00 0.22
D -C 0.22 1 C 0.00 0.22
-----Gable Webs-----
D -B 0.03 90 T
TL Defl -0.05" in D -C L/999
LL Defl -0.02" in D -C L/999
Shear // Grain in B -C 0.15

Plates for each ply each face.
Plate - MT20 20 Ga, Gross Area
Plate - MT2H 20 Ga, Gross Area
Plate - MS18 18 Ga, Gross Area
Jt Type Plt Size X Y JSI
A MT20 3.0x 5.0 Ctr Ctr 0.43
B MT20 5.0x 5.0 Ctr Ctr 0.43
C MT20 3.0x 5.0 Ctr Ctr 0.43
D MT20 2.0x 4.0 Ctr Ctr 0.00

REVIEWED BY:
MiTek Industries, Inc.
6904 Parke East Blvd.
Tampa, FL 33610

REFER TO ONLINE PLUS GENERAL
NOTES AND SYMBOLS SHEET FOR
ADDITIONAL SPECIFICATIONS.

NOTES:
Trusses Manufactured by:
RIDGWAY ROOF TRUSS

Analysis Conforms To:
FBC2010
TPI 2007
Design checked for 10 psf non-
concurrent LL on BC.
Wind Loads - ANSI / ASCE 7-10

Truss is designed as
Components and Claddings*
for Exterior zone location.
Wind Speed: 130 mph
Risk Category : II
Mean Roof Height: 25-0
Exposure Category: B
Building Type: Enclosed
TC Dead Load: 4.0 psf
BC Dead Load: 6.0 psf
Max comp. force 246 Lbs
Max tens. force 156 Lbs
Connector Plate Fabrication
Tolerance = 20%
This truss is designed for a
creep factor of 1.5 which
is used to calculate total
load deflection.

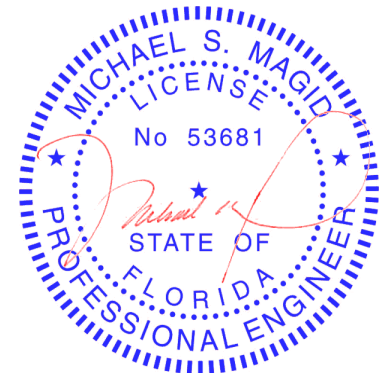

FL Cert. 6634

Job 120440	Mark V4	Quan 3	Type VL	Span 150904	Pl-H1 9	Left OH 0	Right OH 0	Engineering T4462884
----------------------	-------------------	-----------	------------	----------------	------------	--------------	---------------	--------------------------------

18- Rosas- Dreambuilders

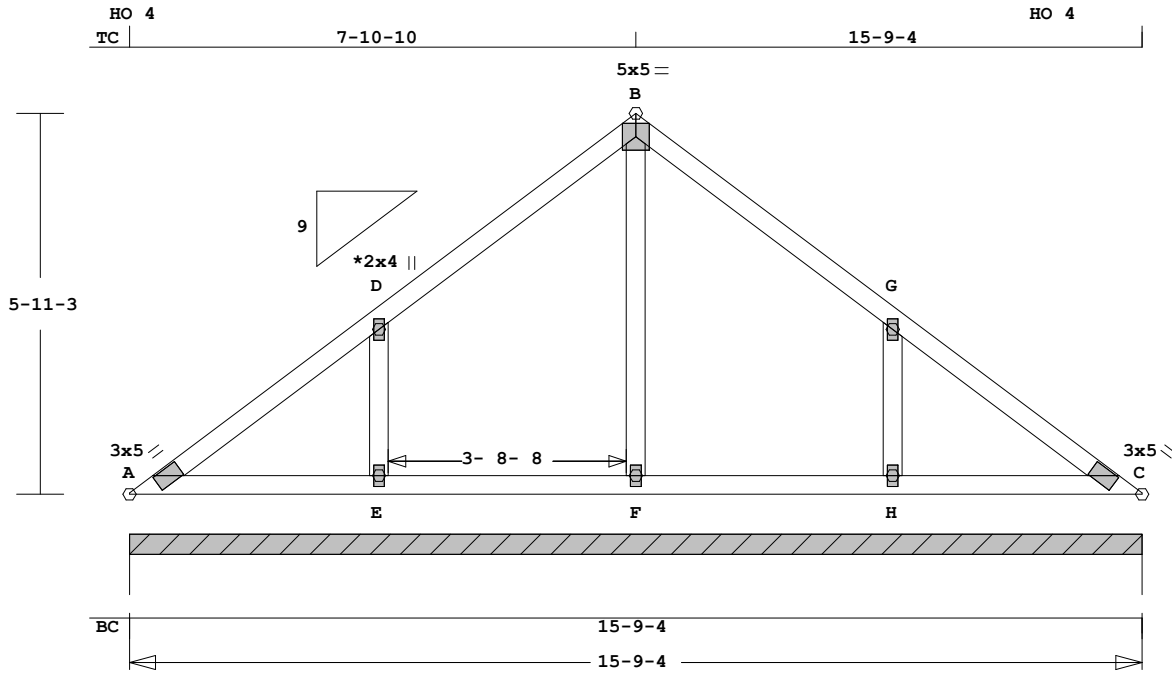

ALL PLATES ARE MT2020

See Joint D For Typical Gable Plate Size and Placement

Scale: 0.334" = 1'

MiTek® Online Plus™ APPROX. TRUSS WEIGHT: 84.3 LBS

Online Plus -- Version 30.0.011
RUN DATE: 18-JUL-12

Southern Pine lumber design values are those effective

06-01-12 by SPIB//ALSC UON

CSI -Size- ---Lumber----

TC 0.15 2x 4 SP-#2

BC 0.09 2x 4 SP-#2

GW 0.09 2x 4 SP-#3

Brace truss as follows:

O.C.	From	To
TC Cont.	0- 0- 0	15- 9- 4
or 48.0"	0- 0- 0	15- 9- 4
BC Cont.	0- 0- 0	15- 9- 4
or 72.0"	0- 0- 0	15- 9- 4

psf-Ld	Dead	Live	Spacing
TC	7.0	20.0	
BC	10.0	0.0	
TC+BC	17.0	20.0	
Total	37.0		24.0"

Lumber	Duration Factor	Plate	Duration Factor	Fb	Fc	Ft	Emin
TC	1.25			1.15	1.10	1.10	1.10
BC	1.25			1.10	1.10	1.10	1.10

Total Load Reactions (Lbs)

Jt	Down	Uplift	Horiz-
A	1106	265 U	113 R

Jt	Brg Size	Required
A	189.2"	0"-to- 189"

Plus 21 Wind Load Case(s)
Plus 1 UBC LL Load Case(s)
Plus 1 DL Load Case(s)

Membr	CSI	P	Lbs	Ax1	CSI-Bnd
-----Top Chords-----					
A	-D	0.14	90 C	0.00	0.14
D	-B	0.14	124 C	0.00	0.14
B	-G	0.15	124 C	0.00	0.15
G	-C	0.15	104 C	0.00	0.15
-----Bottom Chords-----					

A -E	0.08	0 T	0.00	0.08
E -F	0.09	0 T	0.00	0.09
F -H	0.09	0 T	0.00	0.09
H -C	0.09	1 C	0.00	0.09
-----Gable Webs-----				
E -D	0.06	248 C		
F -B	0.09	110 C		
H -G	0.06	254 C		

TL Defl	0.00"	in H -C	L/999
LL Defl	0.00"	in E -F	L/999
Shear // Grain		in D -B	0.11

Plates for each ply each face.	Plate -	MT20	20 Ga,	Gross Area
Plate -	MT2H	20 Ga, <td>Gross Area</td> <td></td>	Gross Area	
Plate -	MS18	18 Ga, <td>Gross Area</td> <td></td>	Gross Area	
Jt Type	Plt Size	X	Y	JSI
A	MT20	3.0x 5.0	Ctr Ctr	0.43
D	MT20	2.0x 4.0	Ctr Ctr	0.00
B	MT20	5.0x 5.0	Ctr Ctr	0.33
G	MT20	2.0x 4.0	Ctr Ctr	0.00
C	MT20	3.0x 5.0	Ctr Ctr	0.43
E	MT20	2.0x 4.0	Ctr Ctr	0.00
F	MT20	2.0x 4.0	Ctr Ctr	0.00
H	MT20	2.0x 4.0	Ctr Ctr	0.00

REVIEWED BY:
MiTek Industries, Inc.
6904 Parke East Blvd.
Tampa, FL 33610

REFER TO ONLINE PLUS GENERAL NOTES AND SYMBOLS SHEET FOR ADDITIONAL SPECIFICATIONS.

NOTES:
Trusses Manufactured by:
RIDGWAY ROOF TRUSS
Analysis Conforms To:
FBC2010
TPI 2007
Design checked for 10 psf non-concurrent LL on BC.
Wind Loads - ANSI / ASCE 7-10
Truss is designed as
Components and Claddings*

for Exterior zone location.
Wind Speed: 130 mph
Risk Category : II
Mean Roof Height: 25-0
Exposure Category: B
Building Type: Enclosed
TC Dead Load: 4.0 psf
BC Dead Load: 6.0 psf
Max comp. force 254 Lbs
Max tens. force 204 Lbs
Connector Plate Fabrication
Tolerance = 20%

This truss is designed for a creep factor of 1.5 which is used to calculate total load deflection.

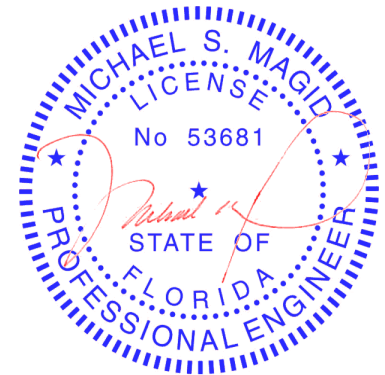

FL Cert. 6634

Job 120440	Mark V5	Quan 2	Type VL	Span 190904	Pl-H1 9	Left OH 0	Right OH 0	Engineering T4462885
----------------------	-------------------	-----------	------------	----------------	------------	--------------	---------------	--------------------------------

18- Rosas- Dreambuilders

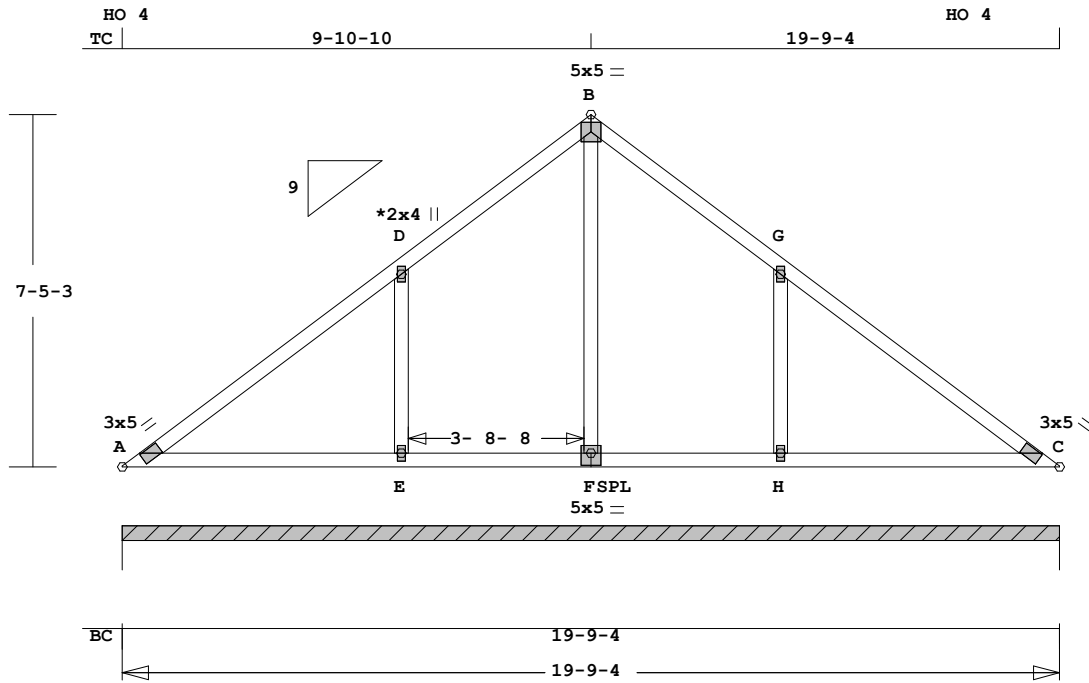

ALL PLATES ARE MT2020
See Joint D For Typical Gable Plate Size and Placement

Scale: 0.247" = 1'

Online Plus -- Version 30.0.011
RUN DATE: 18-JUL-12

Southern Pine lumber design values are those effective 06-01-12 by SPIB//ALSC UON
CSI -Size- ---Lumber----

TC	0.28	2x 4	SP-#2
BC	0.21	2x 4	SP-#2
GW	0.14	2x 4	SP-#3

Brace truss as follows:

O.C.	From	To
TC Cont.	0- 0- 0	19- 9- 4
or 48.0"	0- 0- 0	19- 9- 4
BC Cont.	0- 0- 0	19- 9- 4
or 72.0"	0- 0- 0	19- 9- 4

psf-Ld	Dead	Live	Spacing	
TC	7.0	20.0	24.0"	
BC	10.0	0.0		
TC+BC	17.0	20.0		
Total	37.0		24.0"	
Lumber Duration Factor	1.25			
Plate Duration Factor	1.25			
	Fb	Fc	Ft	Emin
TC	1.15	1.10	1.10	1.10
BC	1.10	1.10	1.10	1.10

Total Load Reactions (Lbs)
Jt Down Uplift Horiz-
A 1402 336 U 143 R

Jt	Brg Size	Required
A	237.2"	0"-to- 237"

Plus 21 Wind Load Case(s)
Plus 1 UBC LL Load Case(s)
Plus 1 DL Load Case(s)

Membr	CSI	P Lbs	Ax1	CSI-Bnd
-----Top Chords-----				
A	-D	0.25	133 C	0.00 0.25
D	-B	0.24	222 C	0.00 0.24
B	-G	0.26	224 C	0.00 0.26
G	-C	0.28	176 C	0.00 0.28
-----Bottom Chords-----				

MiTek® Online Plus™ APPROX. TRUSS WEIGHT: 109.8 LBS

A -E	0.16	0 T	0.00	0.16
E -F	0.16	0 T	0.00	0.16
F -H	0.17	0 T	0.00	0.17
H -C	0.21	1 C	0.00	0.21
-----Gable Webs-----				
E -D	0.12	323 C		
F -B	0.14	124 T		
H -G	0.12	332 C		
TL Defl	-0.05" in H -C L/999			
LL Defl	-0.02" in H -C L/999			
Shear // Grain	in G -C 0.16			

Plates for each ply each face.
Plate - MT20 20 Ga, Gross Area
Plate - MT2H 20 Ga, Gross Area
Plate - MS18 18 Ga, Gross Area
Jt Type Plt Size X Y JSI
A MT20 3.0x 5.0 Ctr Ctr 0.43
D MT20 2.0x 4.0 Ctr Ctr 0.00
B MT20 5.0x 5.0 Ctr Ctr 0.33
G MT20 2.0x 4.0 Ctr Ctr 0.00
C MT20 3.0x 5.0 Ctr Ctr 0.43
E MT20 2.0x 4.0 Ctr Ctr 0.00
F MT20 5.0x 5.0 Ctr-0.5 0.39
H MT20 2.0x 4.0 Ctr Ctr 0.00

REVIEWED BY:
MiTek Industries, Inc.
6904 Parke East Blvd.
Tampa, FL 33610

REFER TO ONLINE PLUS GENERAL NOTES AND SYMBOLS SHEET FOR ADDITIONAL SPECIFICATIONS.

NOTES:
Trusses Manufactured by:
RIDGWAY ROOF TRUSS
Analysis Conforms To:
FBC2010
TPI 2007
Design checked for 10 psf non-concurrent LL on BC.
Wind Loads - ANSI / ASCE 7-10
Truss is designed as
Components and Claddings*

for Exterior zone location.
Wind Speed: 130 mph
Risk Category : II
Mean Roof Height: 25-0
Exposure Category: B
Building Type: Enclosed
TC Dead Load: 4.0 psf
BC Dead Load: 6.0 psf
Max comp. force 332 Lbs
Max tens. force 263 Lbs
Connector Plate Fabrication
Tolerance = 20%
This truss is designed for a creep factor of 1.5 which is used to calculate total load deflection.

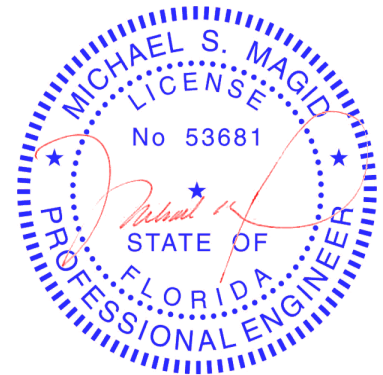

FL Cert. 6634

ONLINE PLUS GENERAL NOTES & SYMBOLS

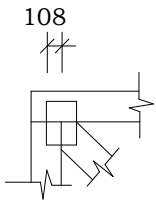
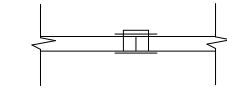

PLATE LOCATION

Center plates on joints unless otherwise noted in plate list or on drawing. Dimensions are given in inches (i.e. 1 1/2" or 1.5") or IN-16ths (i.e. 108)

FLOOR TRUSS SPLICE (3X2, 4X2, 6X2)



(W) = Wide Face Plate
(N) = Narrow Face Plate

LATERAL BRACING

Designates the location for continuous lateral bracing (CLB) for support of individual truss members only. CLBs must be properly anchored or restrained to prevent simultaneous buckling of adjacent truss members.

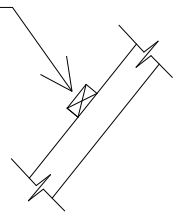
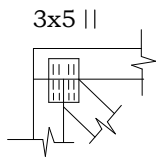

PLATE SIZE AND ORIENTATION



The first dimension is the width measured perpendicular to slots. The second dimension is the length measured parallel to slots. Plate orientation, shown next to plate size, indicates direction of slots in connector plates.

DIMENSIONS

All dimensions are shown in FT-IN-SX (i.e. 6'-8.5" or 6-08-08). Dimensions less than one foot are shown in IN-SX only (i.e. 708).

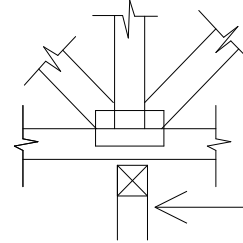
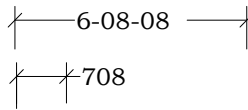

W = Actual Bearing Width (IN-SX)
R = Reaction (lbs.)
U = Uplift (lbs.)

BEARING

When truss is designed to bear on multiple supports, interior bearing locations should be marked on the truss. Interior support or temporary shoring must be in place before trusses are installed. If necessary, shim bearings to assure solid contact with truss.

Metal connector plates shall be applied on both faces of truss at each joint. Center the plates, unless indicated otherwise. No loose knots or wane in plate contact area. Splice only where shown. Overall spans assume 4" bearing at each end, unless indicated otherwise. Cutting and fabrication shall be performed using equipment which produces snug-fitting joints and plates. Unless otherwise noted, moisture content of lumber shall not exceed 19% at time of fabrication and the attached truss designs are not applicable for use with fire retardant lumber and some preservative treatments. Nails specified on Truss Design Drawings refer to common wire nails, except as noted. The attached design drawings were prepared in accordance with " National Design Specifications for Wood Construction" (AF & PA), " National Design Standard for Metal Plate Connected Wood Truss Construction" (ANSI/TPI 1), and HUD Design Criteria for Trussed Rafters.

Mitek Industries Inc. bears no responsibility for the erection of trusses, field bracing or permanent truss bracing. Refer to "Building Component Safety Information" (BCSI 1) as published by Truss Plate Institute, 218 North Lee Street, Suite 312, Alexandria, Virginia 22314. Persons erecting trusses are cautioned to seek professional advice concerning proper erection bracing to prevent toppling and " dominoing ". Care should be taken to prevent damage during fabrication, storage, shipping and erection. Top and bottom chords shall be adequately braced in the absence of sheathing or rigid ceiling, respectively. It is the responsibility of others to ascertain that design loads utilized on these drawings meet or exceed the actual dead loads imposed by the structure and the live loads imposed by the local building code or historical climatic records. When truss hangers are specified on the Truss Design Drawing, they must be installed per manufacturer's details and specifications.

FURNISH A COPY OF THE ATTACHED TRUSS DESIGN DRAWINGS TO ERECTION CONTRACTOR. IT IS THE RESPONSIBILITY OF THE BUILDING DESIGNER TO REVIEW THESE DRAWINGS AND VERIFY THAT DATA, INCLUDING DIMENSIONS & LOADS, CONFORM TO ARCHITECTURAL PLAN / SPECS AND THE TRUSS PLACEMENT DIAGRAM FURNISHED BY THE TRUSS MANUFACTURER.



MiTek USA, Inc.

6904 Parke East Blvd.
Tampa, FL 33610-4115

Tel: 813-972-1135
Fax: 813-971-6117

JOBSITE PACKAGE

IMPORTANT DOCUMENTS ENCLOSED

PLEASE REVIEW



WARNING:

The handling, storing, installing, restraining and diagonal bracing of structural building components requires specialized training, clearly implemented procedures, and careful planning and communication among the contractor, crane operator and installation crew. Handling and installing components without appropriate training, planning and communication greatly increases the probability of an accident resulting in property damage, serious personal injury and/or death.

Prior to component installation, the documents should be examined and disseminated to all appropriate personnel, in addition to proper training and a clear understanding of the installation plan, any applicable fall protection requirements, and the intended restraint and bracing requirements. **Trusses over 60 feet in length are very dangerous to install and may require complex temporary and permanent bracing. Please consult a Registered Design Professional.**

Examine the building, the building's structural framing system, bearing locations and related installation conditions. Begin component installation only after any unsatisfactory conditions have been corrected. Do not cut, modify or repair components. Report any damage before installation.

The enclosed documents are offered as minimum guidelines only. Nothing contained in this jobsite package should be construed in any manner as expanding the scope of responsibility of, or imposing any additional liabilities on, the component manufacturer.

ADVERTENCIA:

El manejo, almacenamiento, instalación, restricción y arrioste diagonal de componentes estructurales de construcción requieren entrenamiento especializada, procedimientos claramente implementados y planificaron y comunicación clara entre el contratista, operador de grúa, y los obreros de instalación. El manejar e instalar los componentes sin entrenamiento suficiente, planificación y comunicación adecuadas aumenta la probabilidad de un accidente que resulta en darea a propiedad, herida seria o muerte.

Antes de la instalación de componentes, los documentos adjuntos deben ser examinados y difundidos a todo el personal apropiado, además del entrenamiento pertinente y un claro entendimiento del plan de instalación, de todo requisito aplicable de la protección contra la caída y de los requisitos previstos de arrioste y restricción. **La instalación de trusses más de 60 pies de largo es muy peligrosa. Consulte a un Profesional de Diseño Registrado.**

Examine la estructura, el sistema armazón estructural de edificio, ubicaciones de soporte e las condiciones de instalación correspondientes y comenzar con la instalación de los componentes sólo después de haber corregido toda condición insatisfactoria. No corte, modifique ni repare los componentes y informe cualquier daño descubierto antes de proceder a la instalación.

Los documentos adjuntos se ofrecen solamente como directrices mínimas. Nada de lo incluido en este paquete debe interpretarse de manera que exceda el alcance de la responsabilidad del fabricante de componentes, ni en forma tal que imponga responsabilidades adicionales sobre éste.

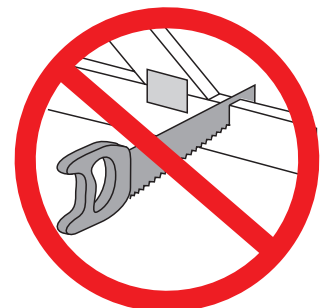
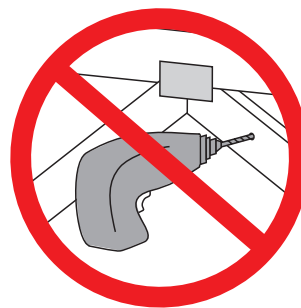
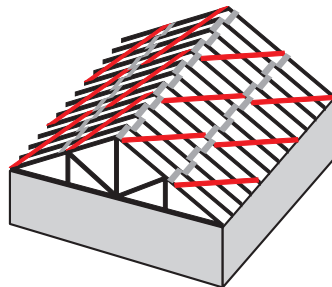
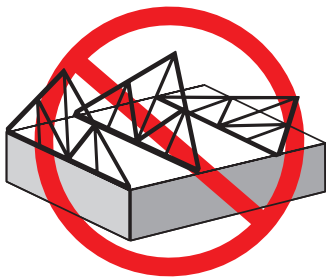

To view a non-printing PDF of this document, visit www.sbcindustry.com/jobsitecs.

FOR DESIGN RESPONSIBILITIES SEE REVERSE

BCSI-B1 SUMMARY SHEET GUIDE FOR HANDLING, INSTALLING, RESTRAINING AND BRACING OF TRUSSES SPANS OVER 60' MAY REQUIRE COMPLEX PERMANENT BRACING. PLEASE ALWAYS CONSULT A PROFESSIONAL ENGINEER

GENERAL NOTES

Trusses are not marked in any way to identify the frequency or location of temporary lateral restraint and diagonal bracing. Follow the recommendations for handling, installing and temporary restraining and bracing of trusses. Refer to **BCSI Guide to Good Practice for Handling, Installing, Restraining & Bracing of Metal Plate Connected Wood Trusses***** for more detailed information.

Truss Design Drawings may specify locations of permanent lateral restraint or reinforcement for individual truss members. Refer to the **BCSI-B3 Summary Sheet - Permanent Restraint/Bracing of Chords & Web Members***** for more information. All other permanent bracing design is the responsibility of the Building Designer.

NOTAS GENERALES

Los trusses no están marcados de ningún modo que identifique la frecuencia o localización de restricción lateral y arrioste diagonal temporales. Use las recomendaciones de manejo, instalación, restricción y arrioste temporal de los trusses. Vea el folleto **BCSI Guía de Buena Práctica para el Manejo, Instalación, Restricción y Arrioste de los Trusses de Madera Conectados con Placas de Metal***** para información más detallada.

Los dibujos de diseño de los trusses pueden especificar las localizaciones de restricción lateral permanente o refuerzo en los miembros individuales del truss. Vea la hoja resumen **BCSI-B3 - Restricción/Arrioste Permanente de Cuerdas y Miembros Secundarios***** para más información. El resto de los diseños de arriostres permanentes son la responsabilidad del Diseñador del Edificio.

⚠ The consequences of improper handling, erecting, installing, restraining and bracing can result in a collapse of the structure, or worse, serious personal injury or death.

El resultado de un manejo, levantamiento, instalación, restricción y arrioste incorrecto puede ser la caída de la estructura o aún peor, heridos o muertos.

⚠ Banding and truss plates have sharp edges. Wear gloves when handling and safety glasses when cutting banding.

Empaques y placas de metal tienen bordes afilados. Lleve guantes y lentes protectores cuando corte los empaques.

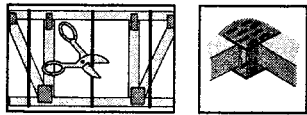
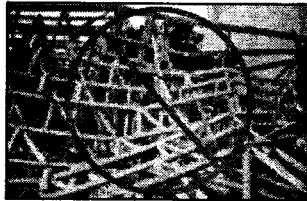

HANDLING — MANEJO

⚠ Avoid lateral bending. — Evite la flexión lateral.



⚠ Use special care in windy weather or near power lines and airports.

Utilice cuidado especial en días ventosos o cerca de cables eléctricos o de aeropuertos.

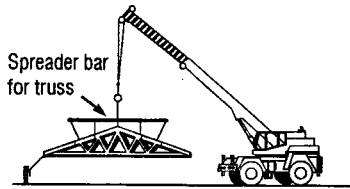

✓ Use proper rigging and hoisting equipment.

Use equipo apropiado para levantar e improvisar.



⚠ The contractor is responsible for properly receiving, unloading and storing the trusses at the jobsite.

El contratista tiene la responsabilidad de recibir, descargar y almacenar adecuadamente los trusses en la obra.

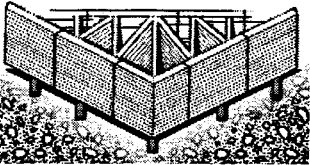

✓ If trusses are to be stored horizontally, place blocking of sufficient height beneath the stack of trusses at 8' to 10' on center.

For trusses stored for more than one week, cover bundles to prevent moisture gain but allow for ventilation.

Refer to **BCSI Guide to Good Practice for Handling, Installing, Restraining & Bracing of Metal Plate Connected Wood Trusses***** for more detailed information pertaining to handling and jobsite storage of trusses.

Si los trusses estarán guardados horizontalmente, ponga bloqueando de altura suficiente detrás de la pila de los trusses a 8 hasta 10 pies en el centro.

Para trusses guardados por más de una semana, cubra los paquetes para prevenir aumento de humedad pero permita ventilación.

Vea el folleto **BCSI Guía de Buena Práctica para el Manejo, Instalación, Restricción y Arrioste de los Trusses de Madera Conectados con Placas de Metal***** para información más detallada sobre el manejo y almacenado de los trusses en área de trabajo.

⊘ Do not store unbraced bundles upright.

No almacene verticalmente los trusses sueltos.



⊘ Do not store on uneven ground.

No almacene en tierra desigual.



HOISTING RECOMMENDATIONS FOR TRUSS BUNDLES RECOMENDACIONES PARA LEVANTAR PAQUETES DE TRUSSES.

⚠ Warning! Don't overload the crane.
¡Advertencia! No sobrecargue la grúa!

⊘ Never use banding alone to lift a bundle. Do not lift a group of individually banded bundles.

Nunca use sólo los empaques para levantar un paquete. No levante un grupo de paquetes empaqueados individualmente.

✓ A single lift point may be used for bundles with trusses up to 45'. Two lift points may be used for bundles with trusses up to 60'. Use at least 3 lift points for bundles with trusses greater than 60'.

Puede usar un solo lugar de levantar para paquetes de trusses hasta 45 pies. Puede usar dos puntos de levantar para paquetes hasta 60 pies.

Use por lo menos tres puntos de levantar para paquetes más de 60 pies.

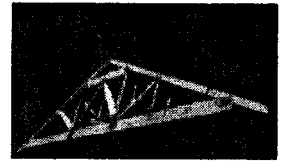

⚠ Warning! Do not over load supporting structure with truss bundle.
¡Advertencia! No sobrecargue la estructura apoyada con el paquete de trusses.

✓ Place truss bundles in stable position. Puse paquetes de trusses en una posición estable.

INSTALLATION OF SINGLE TRUSSES BY HAND INSTALACIÓN DE TRUSSES INDIVIDUALES POR LA MANO

✓ Trusses 20' or less, support at peak.

Soporte del pico los trusses de 20 pies o menos.

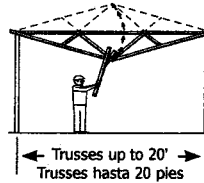

✓ Trusses 30' or less, support at quarter points.

Soporte de los cuartos de tramo los trusses de 30 pies o menos.

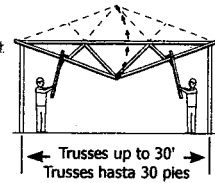

HOISTING OF SINGLE TRUSSES — LEVANTAMIENTO DE TRUSSES INDIVIDUALES

✓ Hold each truss in position with the erection equipment until top chord temporary lateral restraint is installed and the truss is fastened to the bearing points.

Sostenga cada truss en posición con equipo de grúa hasta que la restricción lateral temporal de la cuerda superior esté instalado y el truss está asegurado en los soportes.

⚠ Warning! Using a single pick-point at the peak can damage the truss.

¡Advertencia! El uso de un solo lugar en el pico para levantar puede hacer daño al truss.



HOISTING RECOMMENDATIONS FOR SINGLE TRUSSES RECOMENDACIONES PARA LEVANTAR TRUSSES INDIVIDUALES

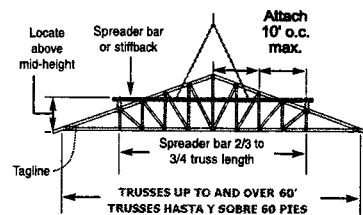
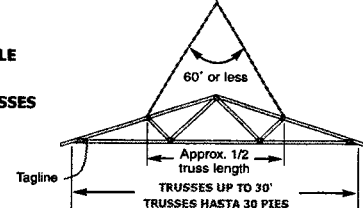
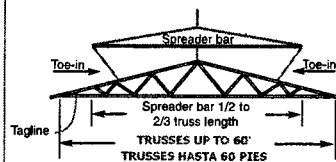

TEMPORARY RESTRAINT & BRACING RESTRICCIÓN Y ARRIOSTRE TEMPORAL

⚠ Refer to **BCSI-B2 Summary Sheet - Truss Installation & Temporary Restraint/Bracing***** for more information.

Vea el resumen **BCSI-B2 - Instalación de Trusses y Restricción/Arrioste Temporal***** para más información.

✓ Locate ground braces for first truss directly in line with all rows of top chord temporary lateral restraint (see table in the next column).

Coloque los arriostres de tierra para el primer truss directamente en línea con cada una de las filas de restricción lateral temporal de la cuerda superior (vea la tabla en la próxima columna).

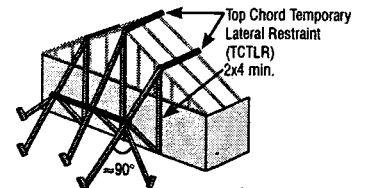

⊘ Do not walk on unbraced trusses.

No camine en trusses sueltos.

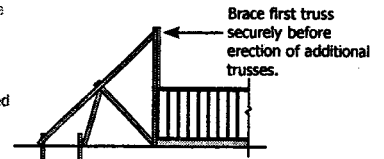

BCSI-B1 SUMMARY SHEET GUIDE FOR HANDLING, INSTALLING, RESTRAINING AND BRACING OF TRUSSES SPANS OVER 60' MAY REQUIRE COMPLEX PERMANENT BRACING. PLEASE ALWAYS CONSULT A PROFESSIONAL ENGINEER!

STEPS TO SETTING TRUSSES LAS MEDIDAS DE LA INSTALACIÓN DE LOS TRUSSES

- 1) Install ground bracing. 2) Set first truss and attach securely to ground bracing. 3) Set next 4 trusses with short member temporary lateral restraint (see below). 4) Install top chord diagonal bracing (see below). 5) Install web member plane diagonal bracing to stabilize the first five trusses (see below). 6) Install bottom chord temporary lateral restraint and diagonal bracing (see below). 7) Repeat process on groups of four trusses until all trusses are set.

1) Instale los arriostres de tierra. 2) Instale el primero truss y ate seguramente al arrioste de tierra. 3) Instale los próximos 4 trusses con restricción lateral temporal de miembro corto (vea abajo). 4) Instale el arrioste diagonal de la cuerda superior (vea abajo). 5) Instale arrioste diagonal para los planos de los miembros secundarios para establezca los primeros cinco trusses (vea abajo). 6) Instale la restricción lateral temporal y arrioste diagonal para la cuerda inferior (vea abajo). 7) Repita este procedimiento en grupos de cuatro trusses hasta que todos los trusses estén instalados.

Refer to BCSI-B2 Summary Sheet - Truss Installation & Temporary Restraint/Bracing*** for more information.

Vea el resumen BCSI-B2 - Instalación de Trusses y Restricción/Arrioste Temporal*** para más información.

RESTRAINT/BRACING FOR ALL PLANES OF TRUSSES RESTRICCIÓN/ARRIOSTRE PARA TODOS PLANOS DE TRUSSES

This restraint & bracing method is for all trusses except 3x2 and 4x2 parallel chord trusses.

Este método de restricción y arrioste es para todo trusses excepto trusses de cuerdas paralelas 3x2 y 4x2.

1) TOP CHORD — CUERDA SUPERIOR

Truss Span Longitud de Tramo	Top Chord Temporary Lateral Restraint (TCTLR) Spacing Espaciamiento del Arrioste Temporal de la Cuerda Superior
Up to 30' Hasta 30 pies	10' o.c. max. 10 pies máximo
30' to 45' 30 a 45 pies	8' o.c. max. 8 pies máximo
45' to 60' 45 a 60 pies	6' o.c. max. 6 pies máximo
60' to 80'* 60 a 80 pies*	4' o.c. max. 4 pies máximo

*Consult a Professional Engineer for trusses longer than 60'.
*Consulte a un Ingeniero Profesional para trusses más de 60 pies.

See BCSI-B2*** for TCTLR options.
Vea el BCSI-B2*** para las opciones de TCTLR.

Refer to BCSI-B3 Summary Sheet - Permanent Restraint/Bracing of Chords & Web Members*** for Gable End Frame restraint/bracing/reinforcement information.

Para información sobre restricción/arrioste/refuerzo para Armazones Hastiales vea el resumen BCSI-B3 - Restricción/Arrioste Permanente de Cuerdas y Miembros Secundarios***

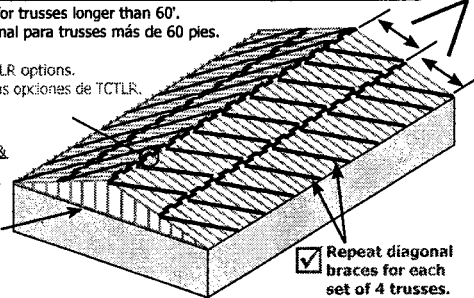

Repeat diagonal braces for each set of 4 trusses.
Repita los arriostres diagonales para cada grupo de 4 trusses.

2) WEB MEMBER PLANE — PLANO DE LOS MIEMBROS SECUNDARIOS

LATERAL RESTRAINT & DIAGONAL BRACING ARE VERY IMPORTANT LA RESTRICCIÓN LATERAL Y EL ARRIOSTRE DIAGONAL SON MUY IMPORTANTES!

10'-15' max. Same spacing as bottom chord Lateral Restraint

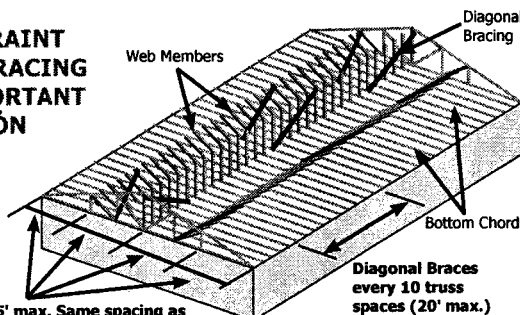

Some chord and web members not shown for clarity.

3) BOTTOM CHORD — CUERDA INFERIOR

Lateral Restraints - 2x4x12' or greater lapped over two trusses.

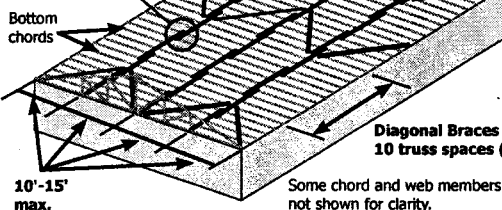

Some chord and web members not shown for clarity.

RESTRAINT & BRACING FOR 3x2 AND 4x2 PARALLEL CHORD TRUSSES RESTRICCIÓN Y ARRIOSTRE PARA TRUSSES DE CUERDAS PARALELAS 3X2 Y 4X2

Refer to BCSI-B7 Summary Sheet - Temporary & Permanent Restraint/Bracing for Parallel Chord Trusses*** for more information.

Vea el resumen BCSI-B7 - Restricción/Arrioste Temporal y Permanente para Trusses de Cuerdas Paralelas*** para más información.

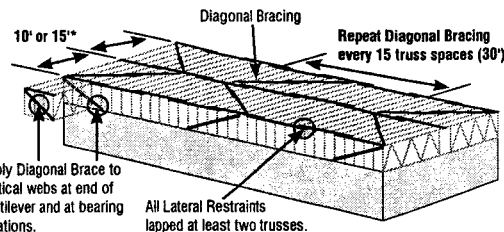

Apply Diagonal Brace to vertical webs at end of cantilever and at bearing locations.

All Lateral Restraints lapped at least two trusses.

*Top chord Temporary Lateral Restraint spacing shall be 10' o.c. max. for 3x2 chords and 15' o.c. for 4x2 chords.

INSTALLING — INSTALACIÓN

Tolerances for Out-of-Plane.
Tolerancias para Fuera-de-Plano.

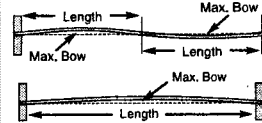

Tolerances for Out-of-Plumb.
Tolerancias para Fuera-de-Plomada.

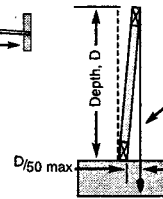

Out of Plumb		Out of Plane	
D/50	D (ft.)	Max. Bow	Truss Length
1/4"	1'	3/4"	12.5'
1/2"	2'	7/8"	14.6'
3/4"	3'	1"	16.7'
1"	4'	1-1/8"	18.8'
1-1/4"	5'	1-1/4"	20.8'
1-1/2"	6'	1-3/8"	22.9'
1-3/4"	7'	1-1/2"	25.0'
2"	≥8'	1-3/4"	29.2'
		2"	≥33.3'

CONSTRUCTION LOADING — CARGA DE CONSTRUCCIÓN

Do not proceed with construction until all lateral restraint and bracing is securely and properly in place.

No proceda con la construcción hasta que todas las restricciones laterales y los arriostres estén colocados en forma apropiada y segura.

Do not exceed maximum stack heights. Refer to BCSI-B4 Summary Sheet - Construction Loading*** for more information.

No exceda las alturas máximas de montón. Vea el resumen BCSI-B4 Carga de Construcción*** para más información.

Maximum Stack Height for Material on Trusses	
Material	Height
Gypsum Board	12"
Plywood or OSB	16"
Asphalt Shingles	2 bundles
Concrete Block	8"
Clay Tile	3-4 tiles high

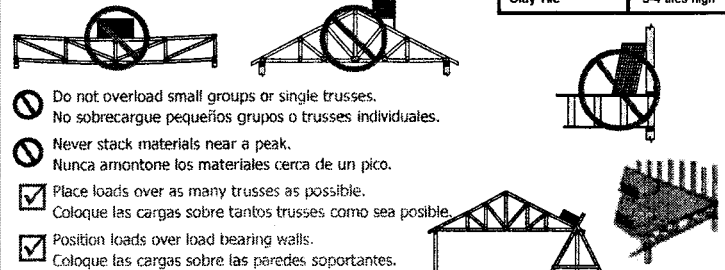

ALTERATIONS — ALTERACIONES

Refer to BCSI-B5 Summary Sheet - Truss Damage, Jobsite Modifications & Installation Errors.*** Vea el resumen BCSI-B5 Daños de Trusses, Modificaciones en la Obra y Errores de Instalación.***

Do not cut, alter, or drill any structural member of a truss unless specifically permitted by the Truss Design Drawing.

No corte, altere o perforo ningún miembro estructural de un truss, a menos que esté específicamente permitido en el Dibujo del Diseño del Truss.

Trusses that have been overloaded during construction or altered without the Truss Manufacturer's prior approval may render the Truss Manufacturer's limited warranty null and void.

Trusses que se han sobrecargado durante la construcción o han sido alterados sin la autorización previa del Fabricante de Trusses, pueden hacer nulo y sin efecto la garantía limitada del Fabricante de Trusses.

***Contact the Component Manufacturer for more information or consult a Professional Engineer for assistance. To view a non-printing PDF of this document, visit www.sbciindustry.com/b1.

NOTE: The Truss Manufacturer and Truss Designer rely on the presumption that the Contractor and crane operator (if applicable) are professionals with the capability to undertake the work they have agreed to do on any given project. If the Contractor believes it needs assistance in some aspect of the construction project, it should seek assistance from a competent party. The methods and procedures outlined in this document are intended to ensure that the overall construction techniques employed will put the trusses into place SAFELY. These recommendations for handling, installing, restraining and bracing trusses are based upon the collective experience of leading personnel involved with truss design, manufacture and installation, but must, due to the nature of responsibilities involved, be presented only as a GUIDE for use by a qualified Building Designer or Contractor. It is not intended that these recommendations be interpreted as superior to the Building Designer's design specification for handling, installing, restraining and bracing trusses and it does not preclude the use of other equivalent methods for restraining/bracing and providing stability for the walls, columns, floors, roofs and all the interrelated structural building components as determined by the Contractor. Thus, WTCA and TPI expressly disclaim any responsibility for damages arising from the use, application, or reliance on the recommendations and information contained herein.

WTCA
WISCONSIN TRUSS AND
BUILDING COMPONENTS INSTITUTE
6300 Enterprise Lane • Madison, WI 53719
608/274-4849 • www.sbciindustry.com

TPI
TRUSS PLATE INSTITUTE
218 N. Lee St., Ste. 312 • Alexandria, VA 22314
703/683-1010 • www.tpinst.org

B2 Truss Installation & Temporary Restraint/Bracing

Instalación de Trusses & Restricción/Arriostre Temporal

FOR TRUSSES UP TO 2'-0" ON-CENTER AND 80'-0" IN LENGTH

PARA TRUSSES HASTA 2 PIES EN CENTRO Y HASTA 80 PIES DE LONGITUD

⚠ WARNING! Spans over 60' require more complex temporary installation restraint/bracing. Consult a registered design professional.

Los tramos más de 60 pies requieren restricción/arriostre de instalación temporal más complejo. Consulte a un profesional registrado de diseño.

⚠ DANGER! Disregarding handling, installing, restraining and bracing safety recommendations is the major cause of truss erection/installation accidents.

El no seguir las recomendaciones de manejo, instalación, restricción y arriostre es la causa principal de los accidentes durante la erección/instalación de trusses.

NOTE Lateral restraint is NOT adequate without diagonal bracing.
La Restricción Lateral NO es adecuada sin el Arriostre Diagonal.

✓ Always diagonally brace for safety!

¡Siempre arriostre diagonalmente para seguridad!

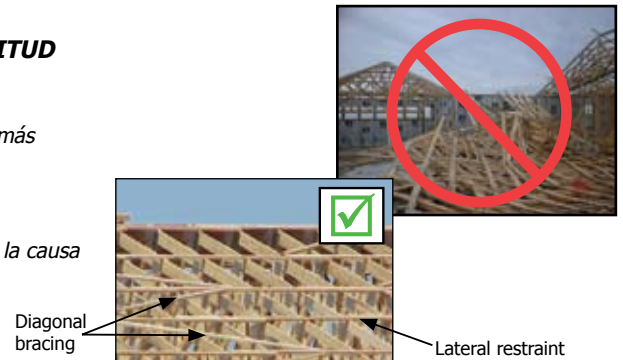

MAXIMUM SPACING FOR TOP CHORD TEMPORARY LATERAL RESTRAINT (TCTLR)

EL ESPACIAMIENTO MÁXIMO PARA LA RESTRICCIÓN LATERAL TEMPORAL DE LA CUERDA SUPERIOR (TCTLR)

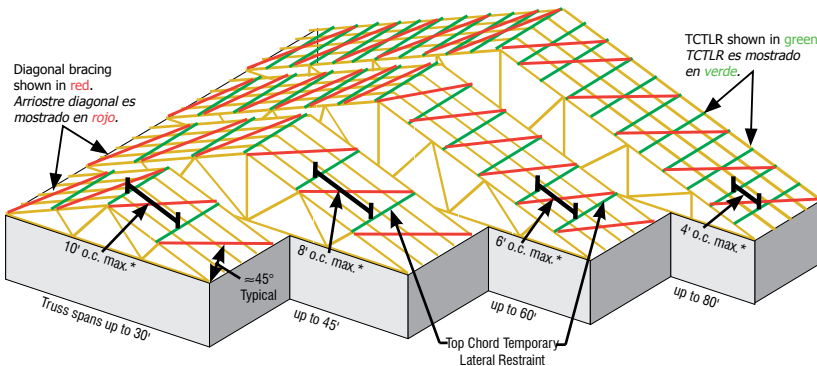

The graphic at left shows the maximum on-center spacing (see * at left) of TCTLR based on truss span from the table in Step 2 on page 2.

- Ground bracing not shown for clarity.
- Apply diagonal bracing or structural sheathing immediately. For spans over 60' applying structural sheathing immediately is the preferred method.

El dibujo a la izquierda muestra el espaciamiento máximo en el centro (vea * a la izquierda) del TCTLR basado en los tramos de trusses de la tabla en el Paso 2 en la página 2.

- No se muestra el arriostre de tierra para claridad.
- Aplique inmediatamente el Arriostre Diagonal o el Entablado Estructural (structural sheathing). Para tramos más de 60 pies el método preferido es entablarlos inmediatamente.

CHECK THESE ITEMS BEFORE STARTING ERECTION/INSTALLATION AND CORRECT AS NEEDED

REVISE ESTOS PUNTOS ANTES DE EMPEZAR LA ERECCIÓN/INSTALACIÓN Y CORRÍJALOS CUANDO ES NECESARIO

- ✓ Building dimensions match the construction documents.
Las dimensiones del edificio concuerdan con los documentos de construcción.
- ✓ Bearing supports (e.g., walls, columns, headers, beams, etc.) are accurately and securely installed, plumb and properly braced.
Los soportes que sostienen cargas (ej., paredes, columnas, vigas de cabecera, vigas, etcétera) son instalados seguramente y con precisión, y son nivelados y arriostrados apropiadamente.
- ✓ Hangers, tie-downs, restraint and bracing materials are on site and accessible.
Los colgadores (hangers), soportes de anclaje (tie-downs) y materiales de restricción y arriostre están accesibles en la obra.
- ✓ Erection/installation crew is aware of installation plan and lateral restraint/diagonal bracing requirements.
El personal de erección/instalación es consciente del plan de instalación y los requisitos de restricción/arriostre.
- ✓ Multi-ply trusses, including girders, are correctly fastened together prior to lifting into place.
Los trusses de varias capas, incluyendo travesaños, son fijados juntos correctamente antes de levantarlos en lugar.
- ✓ Any truss damage is reported to truss manufacturer. Refer to **BCSI-B5**.*** Do not install damaged trusses unless instructed to do so by the building designer, truss designer or truss manufacturer.
Algún daño a los trusses ha sido reportado al fabricante de trusses. Vea el resumen **BCSI-B5**.*** No instale trusses dañados a menos que se dijeran el diseñador del edificio, el diseñador del truss o el fabricante del truss.

- ✓ Trusses are the correct dimension.
Las trusses son la dimensión correcta.
- ✓ Tops of bearing supports are flat, level and at the correct elevation.
La parte superior de los soportes de cojinete son planas, niveladas y a la elevación correcta.
- ✓ Jobsite is clean and neat, and free of obstructions.
La obra está limpia, ordenada y sin obstrucciones.

- ✓ Ground bracing procedure for first truss is based on site and building configuration.
El procedimiento de Arriostre de Tierra para el primer truss es basado en el terreno y la configuración del edificio.

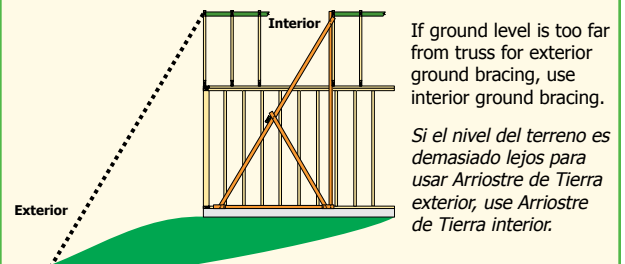

If ground level is too far from truss for exterior ground bracing, use interior ground bracing.
Si el nivel del terreno es demasiado lejos para usar Arriostre de Tierra exterior, use Arriostre de Tierra interior.

STEPS TO SETTING TRUSSES

PASOS PARA EL MONTAJE DE TRUSSES

1. Establish Ground Bracing Procedure: Exterior or Interior
Establezca el Procedimiento de Arriostre de Tierra: Exterior o Interior

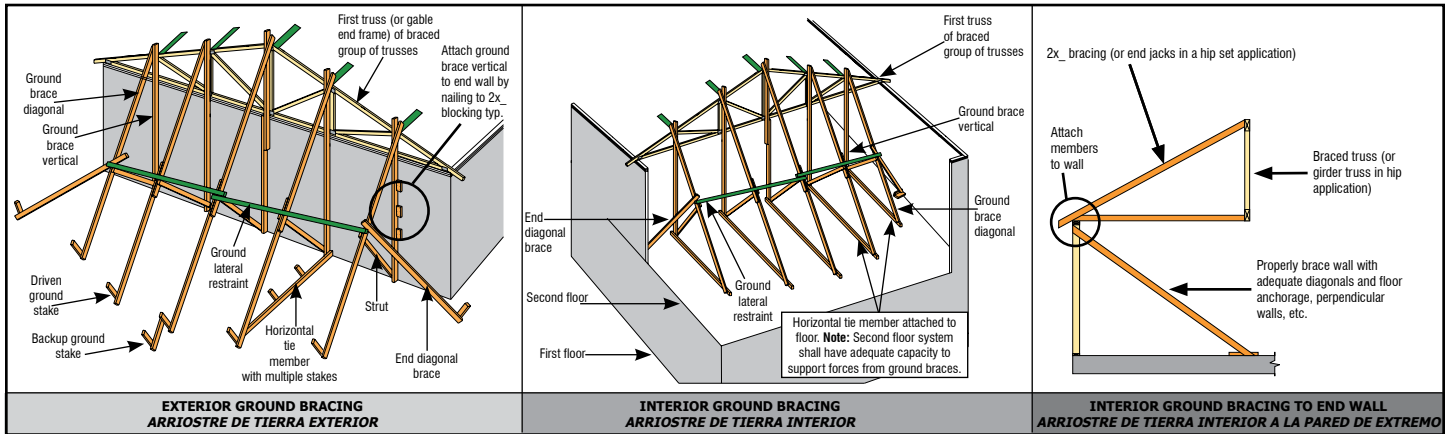

2. Determine the locations for TCTLR and Ground Braces
Determine las ubicaciones para TCTLR y los Arriostres de Tierra

Use truss span to determine spacing for top chord temporary lateral restraint (TCTLR) from table at right. Use the truss span to determine the spacing for top chord temporary lateral restraint (TCTLR) in the table to the right.

Maximum Top Chord Temporary Lateral Restraint Spacing**	
Truss Span	TCTLR Spacing
Up to 30'	10' on-center maximum
30' - 45'	8' on-center maximum
45' - 60'	6' on-center maximum
60' - 80'*	4' on-center maximum

*Consult a registered design professional for trusses longer than 60'.
 **For trusses spaced greater than 2' o.c., see also BCSI-B10.

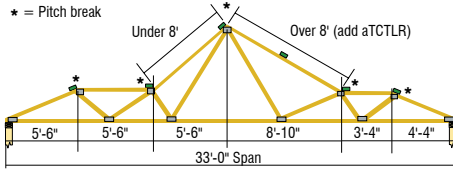

Locate additional TCTLR at each pitch break. Localice TCTLR adicional en cada rotura de inclinación.

Locate additional TCTLR over bearings if the heel height is 10" or greater. Localice TCTLR adicional sobre los soportes si la altura del talón (heel height) es de 10 pulgadas o más.

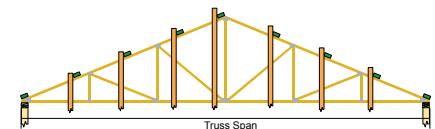
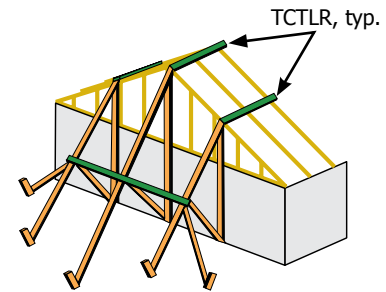
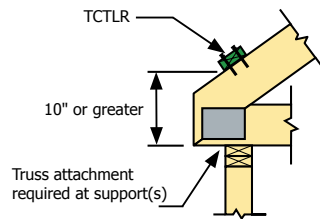

Locate a ground brace vertical at each TCTLR location. Localice una vertical de arriostre de tierra en cada lugar de TCTLR.

3. Set First Truss and Fasten Securely to Ground Braces
Coloque el Primer Truss y Fíjelo Seguramente a los Arriostres de Tierra

Set first truss (or gable end frame) and fasten securely to ground braces and to the wall, or as directed by the building designer. Examples of first truss installed include:

Coloque el primer truss (o armazón hastial) y fíjelo seguramente a las verticales de arriostre de tierra y a la pared, o como se dirige el diseñador del edificio. Ejemplos del primer truss instalado incluyen:

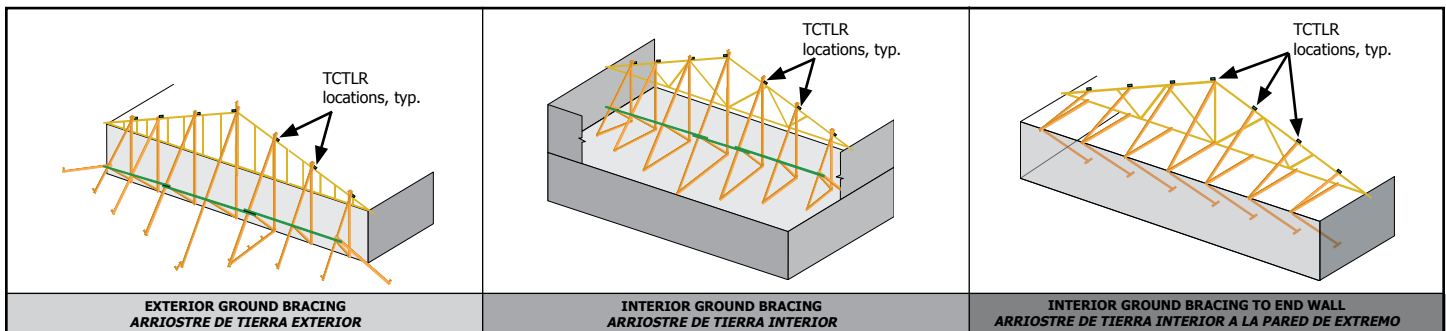

CAUTION! First truss must be attached securely to all bearings and to all required ground braces prior to removing the hoisting supports.

El primer truss tiene que ser sujetado seguramente a todos soportes y a todas arriostres de tierra requeridos, antes de quitar los soportes de levantamiento.

4. Set Trusses 2, 3, 4 & 5 with TCLR in Line with Ground Bracing
Coloque los Trusses 2, 3, 4 y 5 con TCLR en Línea con los Arriostres de Tierra

- Attach trusses securely at all bearings, shimming bearings as necessary. Examples of first five trusses set include: *Sujete seguramente las trusses a todos los soportes, rellenar sólidamente los soportes como sea necesario. Ejemplos de los primeros cinco trusses colocados incluyen:*

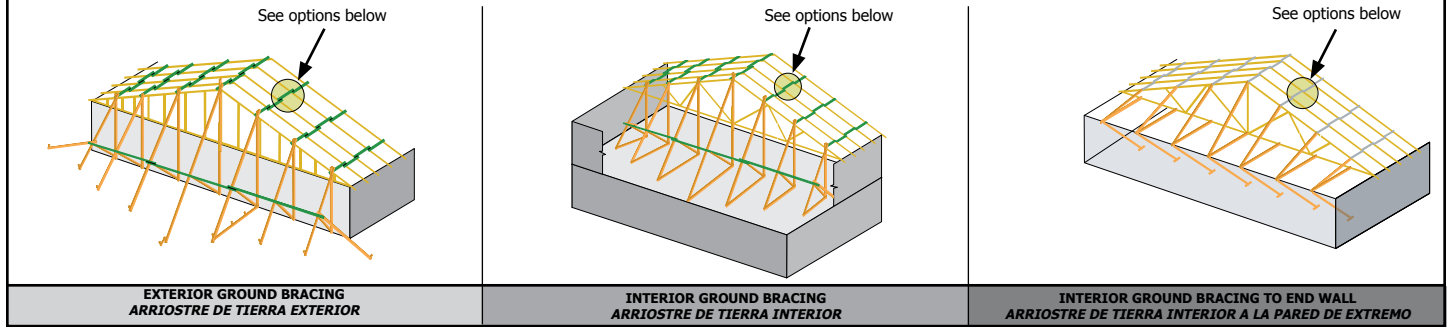

NOTICE The following three (3) Short Member Temporary Lateral Restraint options **require that the diagonal bracing be installed continuously.**
Las siguientes tres opciones para instalar la Restricción Lateral Temporal de los Miembros Cortos requieren que el arriostre diagonal está instalado continuamente.

Option 1
Short member temporary lateral restraint installed on top of trusses

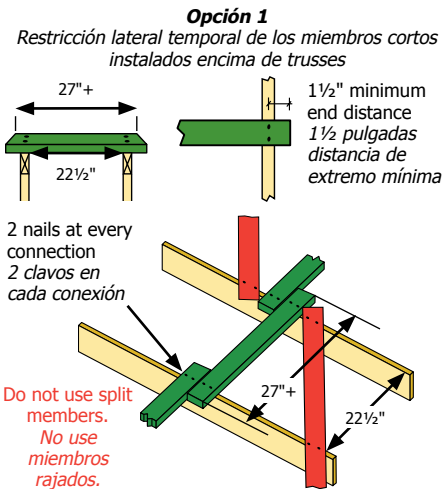

Option 2
Short member temporary lateral restraint installed between trusses

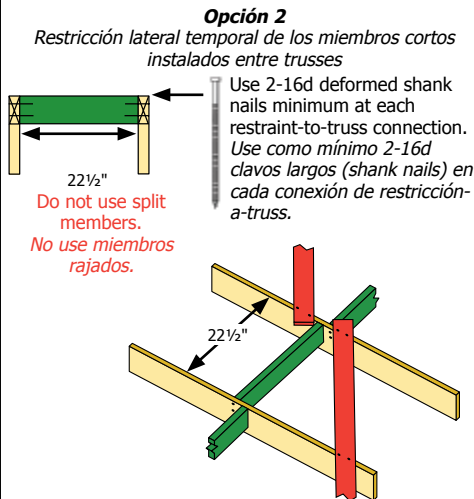

Option 3
Proprietary metal restraint products*

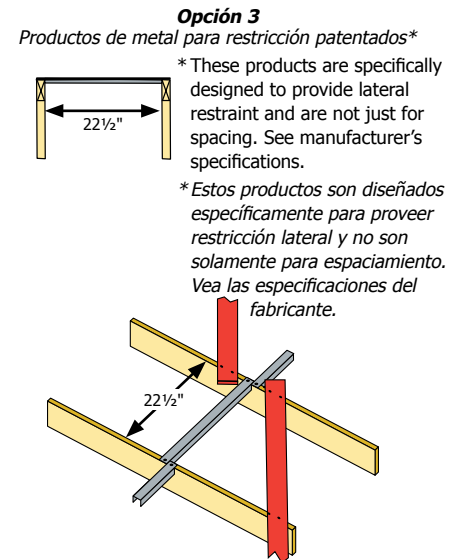

CAUTION! Each truss must be attached securely at each bearing and all TCLR installed before removing the hoisting supports.
Cada truss tiene que ser sujetado seguramente en cada soporte y todas las TCLR instaladas antes de quitar los soportes de levantar.

LATERAL RESTRAINT/BRACING MATERIAL AND CONNECTIONS
CONEXIONES Y MATERIALES DE RESTRICCIÓN/ARRIOSTRE LATERAL

- Minimum size of bracing and lateral restraint material is 2x4 stress-graded lumber or approved proprietary metal restraint/bracing, unless otherwise specified by the building designer.
El tamaño del material de restricción lateral y arriostre debe ser por lo menos 2x4 madera graduada por esfuerzo o restricción/arriostre de metal patentado aprobado, a menos que especifique el diseñador del edificio.
- All bracing and lateral restraint members must be connected to each truss with at least 2 nails (see minimum sizes shown below), except for the short member restraints shown in Step 4, Option 2 (see above), which require 2-16d deformed-shank (i.e., ring- or screw-shank) nails.
Todos los miembros de restricción lateral y arriostre tienen que ser conectados a cada truss con un mínimo de 2 clavos (ver los tamaños mínimos mostrados abajo) excepto para las restricciones de miembros cortos mostrados en el Paso 4, Opción 2 (vea arriba), cuales requieren 2-16d clavos con largos deformados (Ej. Largos de anillos o tornillos).
- Drive nails flush, or use double-headed nails for easiest removal.
Clave los clavos al raso, o use clavos de dos cabezas para quitarlos más fácilmente.

10d (0.128x3")
 12d (0.128x3.25")
 16d (0.131x3.5")

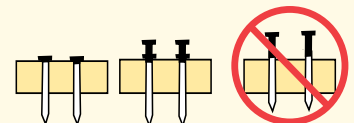

5. Install Top Chord Diagonal Bracing Instale el Arriostre Diagonal de la Cuerda Superior

- ✓ Attach diagonal bracing to the first five trusses. Examples of diagonal bracing on first five trusses include:
Coloque el arriostre diagonal a los primeros cinco trusses. Ejemplos de arriostre diagonal en los primeros cinco trusses incluyen:

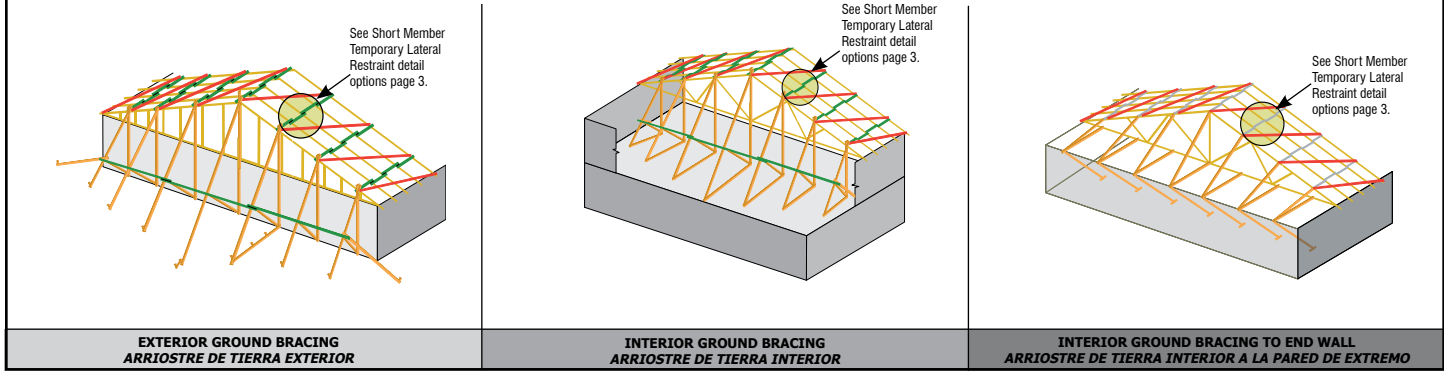

- ✓ Or start applying structural sheathing. Example of structural sheathing installed on first five trusses.
O empiece en aplicar el entablado estructural. Ejemplo de entablado estructural instalado en los primeros cinco trusses.

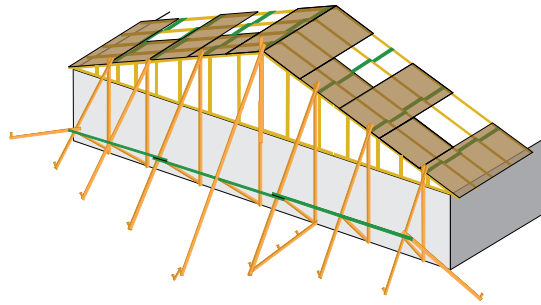

6. Install Web Member Diagonal Bracing Instale el Arriostre Diagonal de Miembros Secundarios

- ✓ Temporary web member diagonal bracing acts with the top chord and bottom chord temporary lateral restraint and diagonal bracing to form triangulation perpendicular to the plane of the truss and prevents trusses from leaning or dominoing.
El arriostre diagonal temporal de los miembros secundarios trabaja con la restricción lateral y el arriostre diagonales de la cuerda superior e inferior para formar una triangulación perpendicular al plano del truss y evita que los trusses se inclinen o caigan como dominós.
- ✓ Install diagonal bracing at about 45° on web members (verticals whenever possible) located at or near rows of bottom chord lateral restraint. Web diagonal bracing must extend from the top chord to the bottom chord. Repeat at the interval shown in the Figure below.
Instale el arriostre diagonal a aproximadamente 45 grados en los miembros secundarios (verticales cuando sea posible) colocados en o cerca de las filas de restricción lateral de la cuerda inferior. Arriostre diagonal para los miembros secundarios tiene que extender de la cuerda superior a la cuerda inferior. Repita a los intervalos mostrados en la Figura a la derecha.

NOTICE The requirements for web member permanent individual truss member restraint are specified on the truss design drawing (TDD). Refer to **BCSI-B3** for more information.
*Los requisitos para la restricción permanente de miembros individuales de truss para miembros secundarios son especificados en el dibujo del diseño de truss. Vea el resumen **BCSI-B3** para más información.*

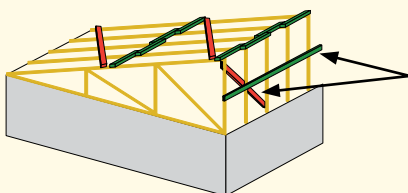
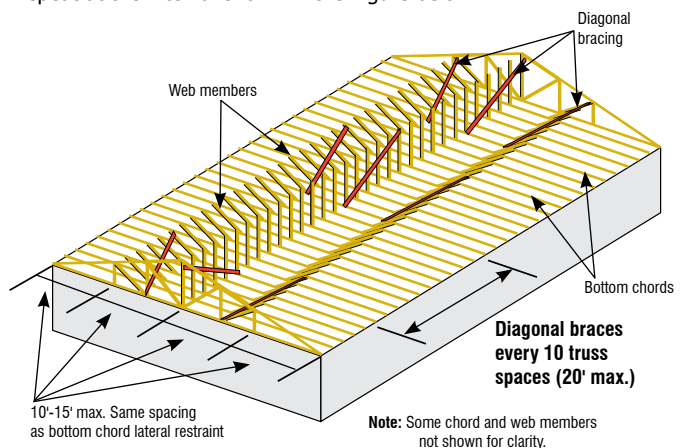

NOTICE Mono trusses, deep flat trusses and other types of trusses with deep ends also require temporary lateral restraint and diagonal bracing on the long web members at the deep end of the truss.
Los trusses de una sola pendiente, trusses planos y profundos y otros tipos de trusses con extremos profundos también requieren restricción lateral temporal y arriostre diagonal en los miembros secundarios largos a la parte profundo del truss.

SPANS OVER 60' MAY REQUIRE COMPLEX PERMANENT BRACING. PLEASE ALWAYS CONSULT A PROFESSIONAL ENGINEER

- WARNING!** Disregarding Permanent Restraint/Bracing is a major cause of truss field performance problems and has been known to lead to roof or floor systems collapse. **¡ADVERTENCIA!** Descuidar el Arriostre/Restricción Permanente es una causa principal de problemas de rendimiento del truss en campo y había conocido a llevar al derrumbamiento del sistema del techo o piso.
- CAUTION!** Spans over 60' may require complex permanent bracing. Please always consult a Registered Design Professional. **¡CAUTELA!** Tramos sobre 60 pies pueden requerir arriostre permanente complejo. Por favor, siempre consulte a un Profesional Registrado de Diseño.

RESTRAINT/BRACING MATERIALS & FASTENERS
MATERIALES Y CIERRES DE RESTRICCIÓN/ARRIOSTRE

- Common restraint/bracing materials include wood structural panels, gypsum board sheathing, stress-graded lumber, proprietary metal products, and metal purlins and straps. **Materiales comunes de arriostre/restringir incluyen paneles estructurales de madera, entablado de yeso, madera graduada por esfuerzo, productos de metal patentados, y vigas de soporte y tiras de metal.**

MINIMUM ATTACHMENT REQUIREMENTS FOR LUMBER RESTRAINT/BRACING^{1,2}

Lumber Size	Minimum Nail Size	Minimum Number of Nails per Connection
2x4 stress-graded	10d (0.128x3")	2
	12d (0.128x3.25")	
	16d (0.131x3.5")	
2x6 stress-graded	10d (0.128x3")	3
	12d (0.128x3.25")	
	16d (0.131x3.5")	

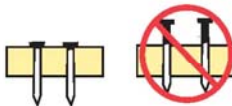

¹ Other attachment requirements may be specified by the Truss Designer or Building Designer.
² The size and attachment for bracing materials such as wood structural panels, gypsum board sheathing, proprietary metal restraint/bracing products, and metal purlins and straps are provided by the Building Designer.

PERMANENT BRACING FOR THE VARIOUS PLANES OF A TRUSS
ARRIOSTRE PERMANENTE PARA VARIOS PLANOS DE UN TRUSS

- Permanent Bracing is important because it,
 - prevents out-of-plane buckling of truss members,
 - helps maintain proper truss spacing, and
 - resists and transfers lateral loads from wind and seismic forces.**El arriostre Permanente es importante porque,**
 - impide el torcer fuera-de-plano de los miembros del truss,
 - ayuda en mantener espaciamento apropiado de los trusses, y
 - resiste y pasa las cargas laterales de viento y fuerzas sísmicas aplicadas al sistema del truss.

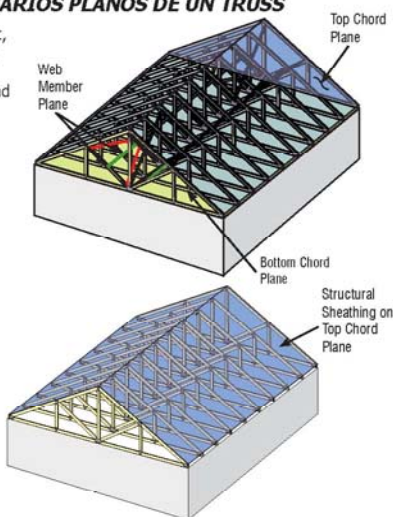

- Trusses require Permanent Bracing within ALL of the following planes:
 - Top Chord Plane
 - Bottom Chord Plane
 - Web Member Plane**Trusses requieren Arriostre Permanente dentro de TODOS los siguientes planos:**
 - Plano de la Cuerda Superior
 - Plano de la Cuerda Inferior
 - Plano del Miembro Secundario

- CAUTION!** Without Permanent Bracing the truss, or a portion of its members, will buckle (i.e., fail) at loads far less than design. **¡CAUTELA!** Sin el Arriostre Permanente, del truss, o un parte de los miembros, torcerán (ej. fallarán) de cargas muchas menos que las cargas que el truss es diseñado a llevar.

1. PERMANENT BRACING FOR THE TOP CHORD PLANE
1. ARRIOSTRE PERMANENTE PARA EL PLANO DE LA CUERDA SUPERIOR

- Use plywood, oriented strand board (OSB), or wood or metal structural purlins that are properly braced. **Use contrachapado, panel de fibras orientadas (OSB), o vigas de soporte de madera o metal que son arriostrados apropiadamente.**
- The Truss Design Drawing (TDD) provides information on the assumed support for the top chord. **El Dibujo del Diseño de Truss (TDD) provee información sobre el soporte supuesto para la cuerda superior.**
- Fastener size and spacing requirements and grade for the sheathing, purlins and bracing are provided in the building code and/or by the Building Designer. **El tamaño de cierre y requisitos de espaciamento y grado para el entablado, vigas de soporte y arriostre son provistos en el código del edificio y/o por el Diseñador del Edificio.**

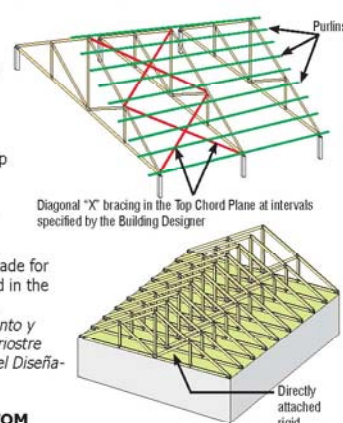

2. PERMANENT BRACING FOR THE BOTTOM CHORD PLANE
2. ARRIOSTRE PERMANENTE PARA EL PLANO DE LA CUERDA INFERIOR

- Use rows of continuous Lateral Restraint with Diagonal Bracing, gypsum board sheathing or rigid ceiling. **Use filas de Restricción Lateral Continua con Arriostre Diagonal, entablado de yeso o techo rígido.**

- The TDD provides information on the assumed support for the bottom chord. **El TDD provee información sobre el soporte supuesto para la cuerda inferior.**
- Install bottom chord permanent Lateral Restraint at the spacing indicated on the TDD and/or by the Building Designer with a maximum of 10' on center. **Instale Restricción Lateral permanente de la cuerda inferior al espaciamento indicado en el TDD y/o por el Diseñador del Edificio con un máximo de 10 pies en el centro.**

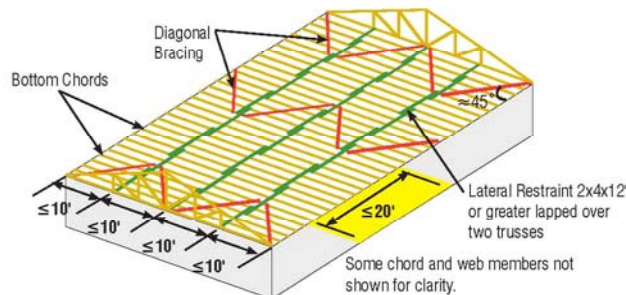

Lateral Restraint and Diagonal Bracing used to brace the Bottom Chord Plane.

3. PERMANENT BRACING FOR THE WEB MEMBER PLANE
3. ARRIOSTRE PERMANENTE PARA EL PLANO DEL MIEMBRO SECUNDARIO

Web Member Permanent Bracing collects and transfers buckling restraint forces and/or lateral loads from wind and seismic forces. The same bracing can often be used for both functions. **Arriostre Permanente de los Miembros Secundarios recogen y pasan fuerzas de restricción de torcer y/o cargas laterales de viento y fuerzas sísmicas. A menudo el mismo arriostre puede ser usado para ambos funciones.**

Individual Web Member Permanent Restraint & Bracing
Restricción y Arriostre Permanente de Miembros Secundarios Individuales

- Check the TDD to determine which web members (if any) require restraint to resist buckling. **Revisa el TDD para determinar cuales miembros secundarios (si algunos) requieren restricción para resistir el torcer.**

- Restrain and brace with,
 - Continuous Lateral Restraint & Diagonal Bracing, or
 - Individual Member Web Reinforcement.**Restrinja y arriostre con,**
 - Restricción Lateral Continua y Arriostre Diagonal, o
 - Refuerzo de Miembros Secundarios Individuales.

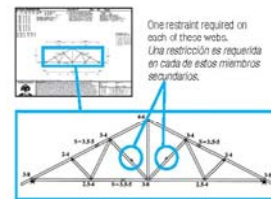

A. Continuous Lateral Restraint (CLR) & Diagonal Bracing
A. Restricción Lateral Continua (CLR) y Arriostre Diagonal

- Attach the CLR at the locations shown on the TDD. **Sujete el CLR en las ubicaciones mostrados en el TDD.**
- Install the Diagonal Bracing at approximately 45° to the CLR and position so that it crosses the web in close proximity to the CLR. Attach the Diagonal Brace as close to the Top and Bottom Chords as possible and to each web it crosses. **Repeat every 20' or less.** **Instale el Arriostre Diagonal a aproximadamente 45 grados al CLR y lo coloque para que cruce la cuerda muy cerca del CLR. Sujete el Arriostre Diagonal como cercano a las cuerdas inferior y superior como sea posible y a cada cuerda que lo cruza. Repita cada 20 pies o menos.**

EXAMPLES OF DIAGONAL BRACING WITH CONTINUOUS LATERAL RESTRAINT

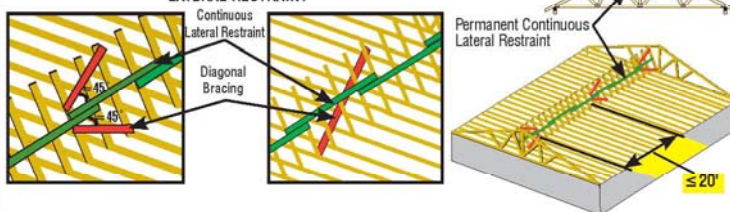

Group of 3 Trusses

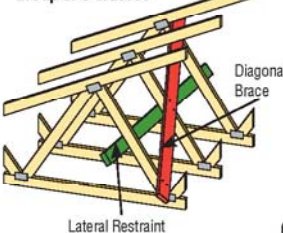

- Lateral Restraint & Diagonal Bracing can also be used with small groups of trusses (i.e., three or less). Attach the Lateral Restraint & Diagonal Brace to each web member that they cross. **Restricción Lateral y Arriostre Diagonal también puede ser usado con grupos pequeños de trusses (ej. tres o menos). Sujete la Restricción Lateral y el Arriostre Diagonal a cada miembro secundario que los cruzan.**

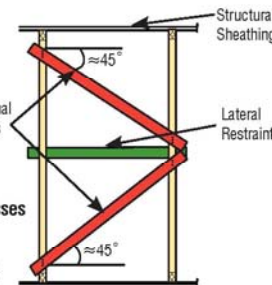

RESTRICCIÓN / ARRIOSTRE PERMANENTE DE LAS CUERDAS Y LOS MIEMBROS SECUNDARIOS

BCSI-B3 SUMMARY SHEET PERMANENT RESTRAINT / BRACING OF CHORDS AND WEB SPANS OVER 60' MAY REQUIRE COMPLEX PERMANENT BRACING. PLEASE ALWAYS CONSULT A PROFESSIONAL ENGINEER

ALWAYS DIAGONALLY BRACE THE CONTINUOUS LATERAL RESTRAINT! SIEMPRE ARRIOSTRE LA RESTRICCIÓN LATERAL CONTINUA DIAGONALMENTE!

B. Individual Web Member Reinforcement B. Refuerzo de Miembros Secundarios Individuales

T-, L-, Scab, I-, U-Reinforcement, proprietary metal reinforcement and stacked web products provide an alternative for resisting web buckling.
T-, L-, costra, I-, U-Refuerzo, refuerzo de metal patentando y productos de miembros secundarios amontonados proveen una alternativa para resistir el torcer de los miembros secundarios.

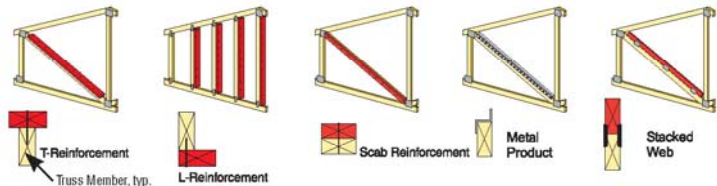

The following table may be used unless more specific information is provided.
La siguiente tabla puede ser usada a menos que información más específica está provista.

WEB REINFORCEMENT FOR SINGLE PLY TRUSSES ¹								
Specified CLR	Size of Truss Web	Type & Size of Web Reinforcement				Grade of Web Reinforcement	Minimum Length of Web Reinforcement	Minimum Connection of Web Reinforcement to Web
		T	L	Scab ²	I			
1 Row	2x4	2x4	2x4	2x4		Same species and grade or better than web member	90% of web or extend to within 6" (150 mm) of end of web member, whichever is greater	16d Gun nails (0.131x3.5") @ 6" (150 mm) on-center ²
	2x6	2x6	2x6	2x6				
	2x8	2x8	2x8	2x8				
	2x4	---	---	---	2-2x4			
2 Rows	2x6	---	---	---	---			
	2x8	---	---	---	---			
	2x8	---	---	---	---			

¹Maximum allowable web length is 14' (4.3 m).
²For Scab Reinforcement use 2 rows of 10d Gun nails (0.120x3") @ 6" (150 mm) on-center to attach reinforcement to web.

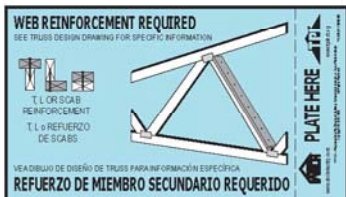
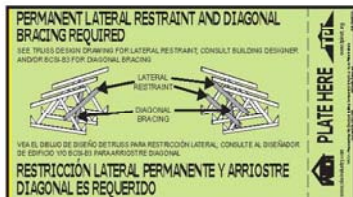

Some Truss Manufacturers mark the locations of the web Lateral Restraint or reinforcement on the truss using tags similar to those above.
Algunos Fabricantes de Trusses marcan en el truss las ubicaciones de refuerzo o Restricción Lateral de miembros secundarios con etiquetas similares a las arriba.

Web Member Plane Permanent Building Stability Bracing to Transfer Wind & Seismic Forces Arrioste de Estabilidad Permanente del Edificio del Plano de Miembros Secundarios para Desplazar Fuerzas de Viento y Fuerzas Sísmicas

The web member restraint or reinforcement specified on a TDD is required to resist buckling under vertical loads. Additional restraint and bracing is typically required to transfer lateral loads due to wind and/or seismic forces. This restraint and bracing is typically provided by the Building Designer.
La restricción o refuerzo de miembros secundarios especificada en un TDD es requerido a resistir el torcer bajo cargas verticales. Restricción y arrioste adicional es requerido típicamente para pasar cargas laterales debidas a fuerzas de viento y/o fuerzas sísmicas. Esta restricción y arrioste es típicamente provisto por el Diseñador del Edificio.

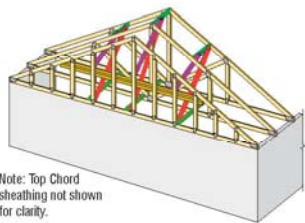

Some Truss Designers provide general design tables and details to assist the Building Designer in determining the Bracing required to transfer lateral loads due to wind and/or seismic forces from the Gable End Frame into the roof and/or ceiling diaphragm.
Algunos Diseñadores de Trusses proveen tablas y detalles de diseño generales para asistir el Diseñador del Edificio en determinar el Arrioste requerido para pasar cargas laterales debidas a fuerzas de viento y/o fuerzas sísmicas del Amazón Hastial al diafragma del techo.

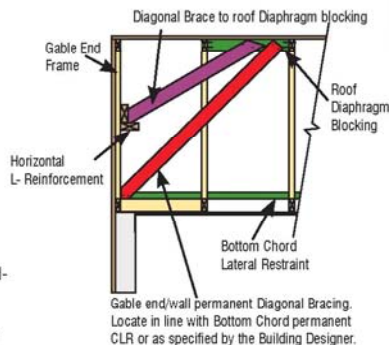

Gable End Frames and Sloped Bottom Chords Arrazones Hastiales Y Cuerdas Inferiores Pendientes

The Gable End Frame should always match the profile of the adjacent trusses to permit installation of proper Bottom Chord Plane restraint & bracing unless special bracing is designed to support the end wall.
El Amazón Hastial siempre debe encajar el perfil de los trusses contiguos para permitir la instalación de restricción y arrioste apropiada de la Cuerda Inferior a menos que arrioste especial es diseñado para soportar la pared de extremo.

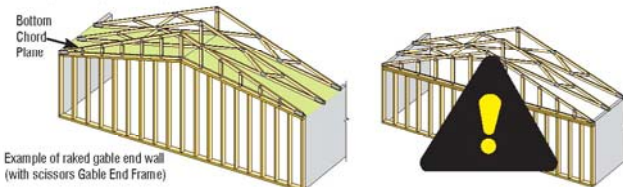

CAUTION! Using a flat Bottom Chord Gable End Frame with adjacent Trusses that have sloped Bottom Chords is prohibited by some building codes as adequate bracing of this condition is difficult and sometimes impossible. Special end wall bracing design considerations are required by the Building Designer if the Gable End Frame profile does not match the adjacent Trusses.

¡CAUTELA! El uso de un Amazón Hastial de la Cuerda Inferior con Trusses contiguos cuales tienen Cuerdas Inferiores pendientes es prohibido por algunos códigos de edificios porque arrioste adecuado de esta condición es difícil y a veces imposible. Consideraciones especiales de diseño para el arrioste de la pared de extremo son requeridos por el Diseñador del Edificio si el perfil del Amazón Hastial no hace juego con los Trusses contiguos.

PERMANENT BRACING FOR SPECIAL CONDITIONS ARRIOSTRE PERMANENTE PARA CONDICIONES ESPECIALES

Sway Bracing—Arrioste de "Sway"

"Sway" bracing is installed at the discretion of the Building Designer to help stabilize the truss system and minimize the lateral movement due to wind and seismic loads.
Arrioste de "Sway" está instalado por la discreción del Diseñador del Edificio para ayudar en estabilizar el sistema de trusses y para minimizar el movimiento lateral debido a cargas de viento y cargas sísmicas.

Sway bracing installed continuously across the building also serves to distribute gravity loads between trusses of varying stiffness.
Arrioste de "Sway" que es instalada continuamente a través del edificio también es usado para distribuir las cargas de gravedad entre trusses de rigidez variando.

Permanent Restraint/Bracing for the Top Chord in a Piggyback Assembly Restricción/Arrioste Permanente para la Cuerda Superior en un Ensamblaje de Piggyback

Provide restraint and bracing by:
• using rows of 4x2 stress-graded lumber CLR and Diagonal Bracing, or
• connecting the CLR into the roof diaphragm, or
• adding Structural Sheathing or Bracing Frames, or
• some other equivalent means.
Provee restricción y arrioste por:
• usando filas de 4x2 CLR madera graduada por esfuerzo y Arrioste Diagonal, o
• conectando el CLR al diafragma del echo, o
• añadiendo Entablado Estructural o Armazones de Arrioste, o
• algunos otros métodos equivalentes.

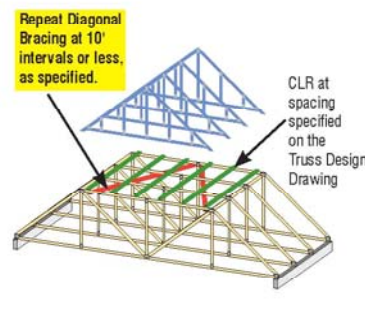

Refer to the TDD for the maximum assumed spacing for attaching the Lateral Restraint to the top chord of the supporting truss.
Refiere al TDD para el espaciamiento máximo supuesto para sujetar la Restricción Lateral a la cuerda superior del truss soportante.

The TDD provides the assumed thickness of the restraint and minimum connection requirements between the cap and the supporting truss or restraint.
El TDD provee el grosor supuesto de la restricción y los requisitos de conexión mínimos entre la capa y el truss soportante o la restricción.

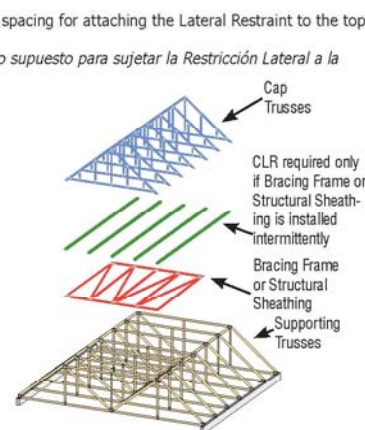

To view a non-printing PDF of this document, visit www.sbcindustry.com/b3.
Para ver un PDF de este documento que no se puede imprimir, visita www.sbcindustry.com/b3.

WICA
REPRESENTING THE STRUCTURAL
BUILDING COMPONENTS INDUSTRY
6300 Enterprise Lane • Madison, WI 53719
608/274-4849 • www.sbcindustry.com

TRUSS PLATE INSTITUTE
218 N. Lee St., Ste. 312 • Alexandria, VA 22314
703/683-1010 • www.tpinst.org

B4 Construction Loading

Cargas de Construcción



Construction loads are those loads imposed on the unfinished building as a result of the construction process. Typical construction loads include the weight of the workers, equipment, and building materials, to name a few. For example, a bundle of plywood sheathing or gypsum board stacked on trusses temporarily creates construction loads.

Cargas de construcción son las cargas que están impuestas a los edificios incompletos como resultado del proceso de construcción. Cargas de construcción típicas incluyen el peso de los trabajadores, el equipo y los materiales de construcción, etcétera. Por ejemplo, un paquete de entablado contrachapado o tabla de yeso apilados temporalmente sobre los trusses crean cargas de construcción.

- ✓ Make sure that the truss assembly is properly restrained and braced according to the guidelines in **BCSI-B1***** and **BCSI-B2***** before placing any construction loads on them. Construction loads shall only be placed on fully restrained and braced structures.

*Asegúrese que el montaje del truss está adecuadamente restringido y arriostrado según las pautas en **BCSI-B1***** y **BCSI-B2***** antes de colocar alguna carga de construcción en la estructura. Solamente coloquen cargas de construcción arriba de estructuras cuales son restringidos y arriostrados completamente.*

- ⚠ **WARNING!** Stacking excessive amounts of construction materials on floor or roof trusses is an unsafe practice. Property damage, personal injury and/or death are possible if this warning is not heeded.

¡ADVERTENCIA! Apilando cantidades excesivas de cargas de construcción sobre trusses de piso u techo es una práctica peligrosa. Daño a la propiedad, herida personal y/o muerte son posibles si no sigue esta advertencia.

- NOTICE** Trusses that have been over-stressed due to excessive construction loading will usually show excessive sagging (deflection) and at least a portion of this deflection will remain even after the load has been removed. In more severe cases, broken truss members and/or failed truss joints may result.

Los trusses que han sido demasiado estresados debido a cargas de construcción excesivas usualmente demuestran una desviación excesiva, y por lo menos una parte de este desviación se quedarán aún después de que la carga se haya quitada. En casos más severos, miembros quebrados del truss y/o juntas falladas pueden resultar.

CONSTRUCTION LOADING **DO'S** AND **DON'TS** QUE **HACER** Y **NO HACER** CON LAS CARGAS DE CONSTRUCCIÓN

- ⊘ **DON'T** exceed stack heights listed in the table.
NO exceda la altura de montón indicada en la tabla que sigue.

- ⊘ **DON'T** stack materials on unbraced trusses.

NO amontone materiales sobre trusses que no esten arriostrados.

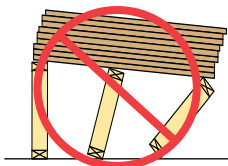

- ⊘ **DON'T** overload the trusses.
NO sobrecargue los trusses.

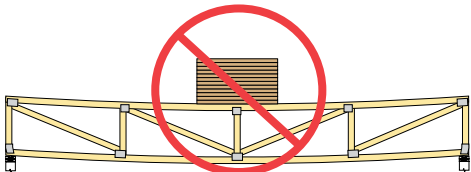

Maximum Stack Height for Material on Trusses <i>Maximua Altura de Montón para Material encima de los Trusses</i>	
Material – Material	Height – Altura
Gypsum Board – Tabla de Yeso	12" – 12 pulgadas
Plywood or OSB – Madera Contrachapada u OSB	16" – 16 pulgadas
Asphalt Shingles – Teja de Asfalto	2 bundles – 2 paquetes
Concrete Block – Bloque de Hormingón	8" – 8 pulgadas
Clay Tile – Teja de Arcilla	3-4 tiles – 3-4 azulejos

Note: Limit stacking periods to approximately one week, unless alternative information is provided by the Building Designer, Truss Designer or Truss Manufacturer.

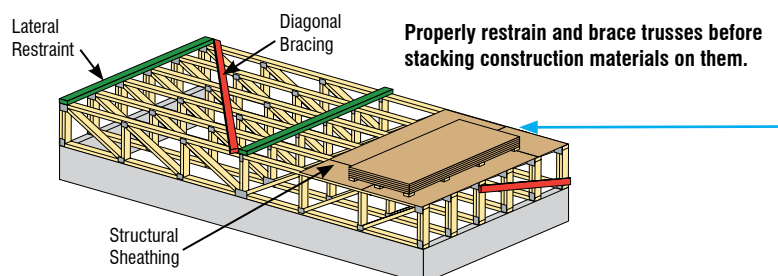

General detail for repair of broken webs, chords, and damaged or missing chord splices that meet the following conditions:
 * Webs must be SPF or better and 2x6 or smaller.
 * Scab must be same size as the broken member.
 * No more than two broken or cracked members per truss.
 * Perimeter of chord break area must be a minimum distance X from any heel or peak, and minimum of 6" away from any interior joint locations.
 * Perimeter of web break area must be a minimum distance X from web joint.
 C = Maximum length of damaged area (not to exceed 12"). S = Overall length of scab (shaded). Must be equal or greater than 2(X)+C.
 X = Minimum length of scab at each end of break area.

Refer to following table for minimum length of scab, and minimum number of nails at each end of break area and maximum axial force of broken member.
 For all lumber, plates, web bracing, etc., refer to original drawing sealed by Robbins Engineering, Inc.
 *Apply all nails so as to avoid damaging of lumber and loosening of plates at joints. Minimum end distance of 2" must be provided for all nails.
 *Use 1 row of 10d common nails spaced 3" on center into 2x3 scabs.
 *Use 2 rows of 10d common nails spaced 3" on center in each row and staggered into 2x4 and 2x5 scabs.
 *Use 3 rows of 10d common nails spaced 3" on center in each row and staggered into 2x6 scabs.

NOTE: Apply scab to one face of truss using nailing as specified above.
 If desired, two scabs may be applied, one to each face of truss; use 6" nail spacing if scabs are applied to each face.

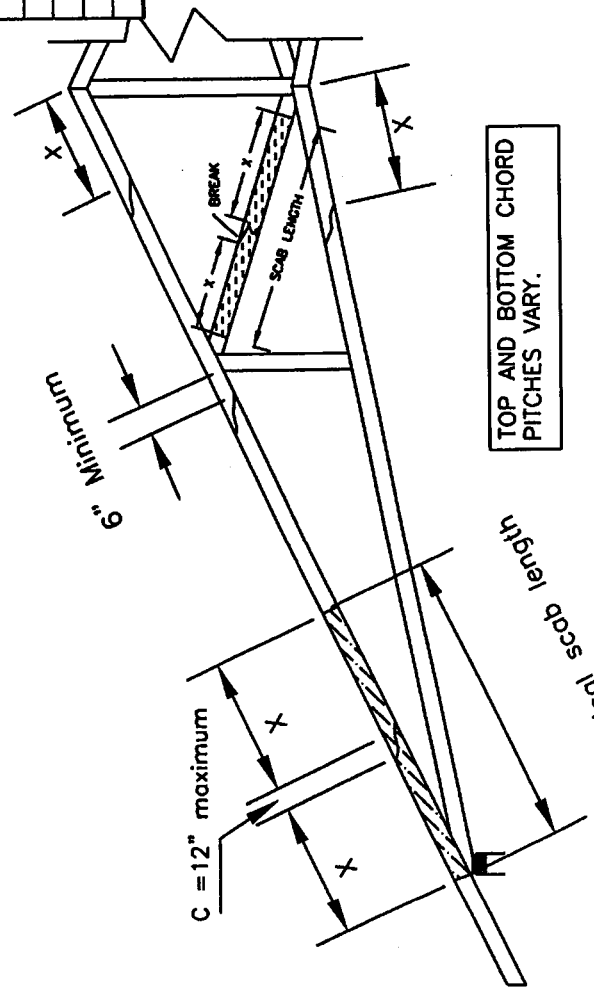

TOP AND BOTTOM CHORD PITCHES VARY.

S: Typical scab length

2x3 SCABS		2x4 or 2x5 SCABS	
MINIMUM X DISTANCE (in.)	MIN. NUMBER OF NAILS AT EACH END OF	MAX. FORCE (lbs) AT 1.15 LOAD DURATION	MINIMUM X DISTANCE (in.)
14	4	460	4
20	6	690	8
26	8	920	12
32	10	1150	16
38	12	1380	20
44	14	1610	24
50	16	1840	28
56	18	2070	32
62	20	2300	36
68	22	2530	40

MINIMUM X DISTANCE (in.)	MIN. NUMBER OF NAILS AT EACH END OF	MAX. FORCE (lbs) AT 1.15 LOAD DURATION
10	6	690
16	12	1380
22	18	2070
28	24	2760
32	28	3220
36	32	3680
40	36	4140
44	40	4600
48	44	5060
52	48	5520

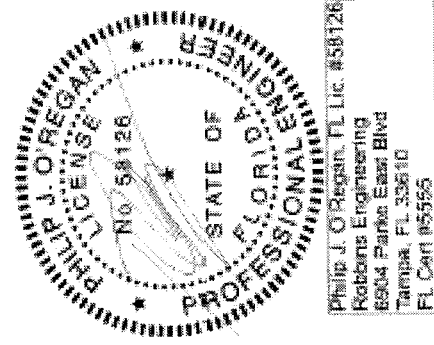

ROBBINS
 Engineering Inc.
 P.O. Box 280055, Tampa, FL 33682

ROBBINS LOCK connector plates (20 sq. yds. steel-ASTM A633 SS Grade 40) field bracing or permanent truss bracing. Refer to H&B-91 as published by the Truss Plate Institute, 583 D'Onofrio Drive, Suite 200, Madison, Wisconsin 53719. Persons erecting trusses are cautioned to seek professional advice concerning proper erection bracing to prevent toppling and "doming". Care should be taken to prevent damage during fabrication, storage, shipping and erection. Top and bottom chords shall be adequately braced in the absence of sheathing or rigid cladding, respectively. The responsibility of others to ascertain that the design team has met its responsibility meet or exceed the actual load loads shown on the structure and the drawing meets or exceeds the local building code or historical climatic records.

FURNISH A COPY OF THIS DESIGN TO ERECTION CONTRACTOR AND TRUSS FAB. TO REVIEW THIS DRAWING & VERIFY THAT DATA INCLUDING DIM. & LOADS CONFORM TO ARCH. PLAN/SPECS & FAB. TRUSS LAYOUTS.

Truss manufacturer must be notified if field conditions do not match this general detail.

Designed By: MC
 Checked By: PO
 Rev. Date: 12/02/05
 Dwg. No: GD-69

General detail for repair of broken, damaged or cut chords of PC42 floor trusses that meet the following conditions.

- * Chord size must be maximum 4x2 and southern pine species.
- * Scab must be at minimum the same size and grade as broken chord. Wide face of scab must be attached to narrow face of chord member.

- * Truss must be single ply.
- * No more than two broken or cracked chords per truss.
- * Perimeter of break area must be minimum of X distance from end of truss.
- * and minimum of 4" away from any plates at panel points. All plates must be intact and fully embedded.

C = Maximum length of damaged area or cut section not to exceed 12".
 S = Overall length of scab member must be equal or greater than 2(X)+C.
 X = Minimum length of scab member at each end of break area.
 Refer to following table for minimum length of scab, and minimum number of nails at each end of break area and maximum axial force of broken member.

For all lumber, plates, web bracing, etc. refer to original drawing sealed by Robbins Engineering Inc.

- 1) Apply all nails so as to avoid damaging of lumber and loosening of plates at joints.
- 2) Attach the scab with one row of 10d common nails at 3" on center into 4x2 chord members. Axial force and number of nails may be doubled or X distance divided by 2, if scabs applied to each face of truss at the same location. Minimum end distance of 3" must be provided for all members.

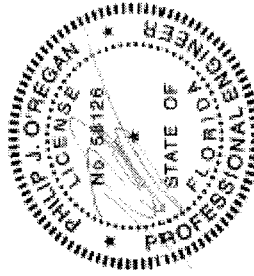

PHILIP J. O'REGAN, P.E. Lic. #58126
 Robbins Engineering
 15004 Parkside East Blvd
 Tampa, FL 33610
 FL Chbr #5555

TOTAL NUMBER OF NAILS AT EACH END OF BREAK	X (INCHES)	MAXIMUM AXIAL FORCE IN CHORD MEMBER (LBS.)
4	18	512
6	24	768
8	30	1024
10	36	1280
12	42	1536
14	48	1792
16	54	2048
18	60	2304
20	66	2560
22	72	2816
24	78	3072

Truss manufacturer must be notified if field conditions do not match this general detail.

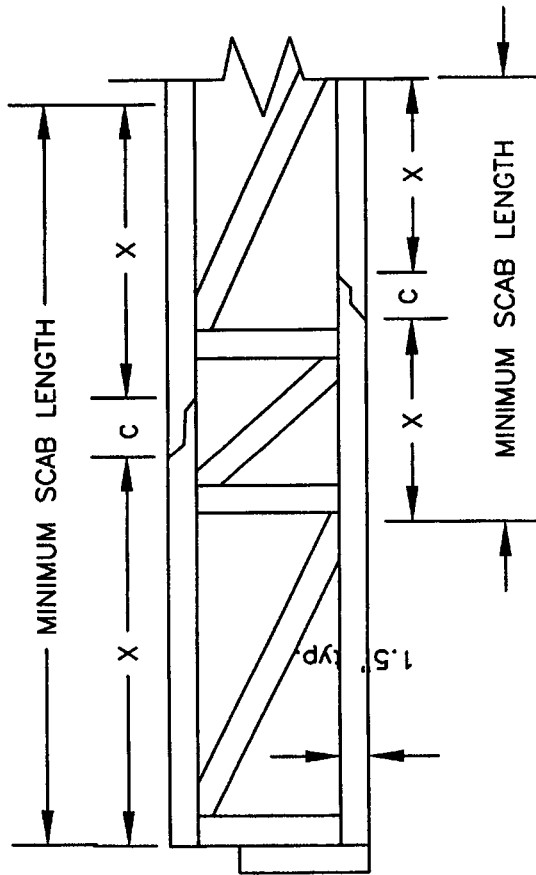

ROBBINS LOCK connector plates (20 ga. gov. steel--ASTM A653 S5 Grade 40) shall be applied on both faces of truss at each joint. Center the plates, unless shown otherwise by circles (ø) or dimensions. Unless otherwise indicated by a "v", all slots in plates run parallel with the chords or horizontally at the peak and / or heel. No loose knots or waves in plate contact area. Splice only where shown. Overall spans assume 4" bearings at each end, unless indicated otherwise. Cutting and fabrications shall be performed on equipment which produces snug-fitting joints and plates. This design was prepared in accordance with the most Design Specifications for Structural Steel and its Fastenings (AISC), Design Specifications for Light Metal Framing and Connected Wood Trusses (TPI), and AIA Design Criteria for Trussed Rafter.

Robbins Mfg. Co. bears no responsibility for the erection of trusses, field bracing or permanent truss bracing. Refer to RB-91 as published by the Truss Plate Institute, 383 D'Oroville Drive, Suite 200, Madison, Wisconsin 53719. Persons erecting trusses are cautioned to seek professional advice concerning proper erection bracing to prevent topping and "doming". Care should be taken to prevent damage during fabrication, storage, shipping and erection. Top and bottom members are to be braced in the chord or bracing to prevent buckling. It is the responsibility of those erecting the design loads specified on this drawing sheet or exceed the actual dead loads imposed by the structure and the live loads imposed by the local building code or historical climatic records.

ROBBINS
 Engineering Inc.
 P.O. Box 280055, Tampa, FL 33682

FURNISH A COPY OF THIS DESIGN TO ERECTION CONTRACTOR AND TRUSS FAB. TO REVIEW THIS DRAWG. & VERIFY THAT DATA INCLUDING DIM. & LOADS CONFORM TO ARCH. PLAN/SPECS & FAB. TRUSS LAYOUTS.

Designed By: MG
 Checked By: TAA
 Rev. Date: 5/17/04
 Dwg. No: GD-62-FL

PERMANENT WEB BRACING

SEE INSIDE DESIGN MANUAL FOR BCSI PERMANENT BRACING
 INSTALLATION INSTRUCTIONS AND FOR FURTHER INFORMATION.
 CONSULT THE ENGINEER OF RECORD FOR EXPLICIT INSTRUCTION
 REGARDING PERMANENT BRACING.

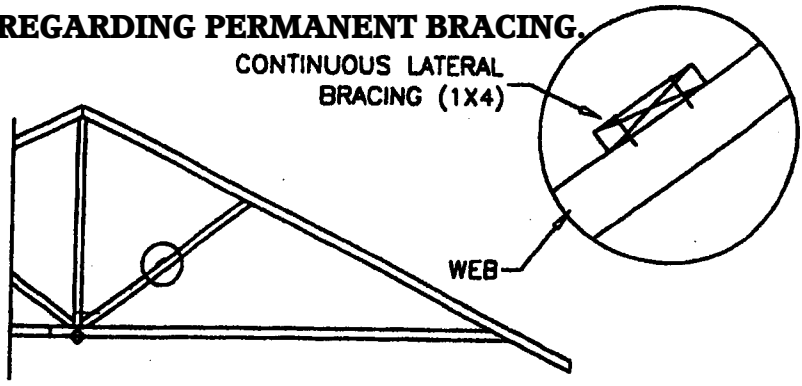

CONTINUOUS LATERAL BRACING

1x4 #3 HEM-FIR OR
 BETTER CONTINUOUS LATERAL
 BRACING TO BE EQUALLY SPACED.
 ATTACH WITH (2) 8d NAILS.
 BRACING MATERIAL TO BE SUPPLIED
 AND ATTACHED AT BOTH ENDS
 TO A SUITABLE SUPPORT BY
 ERECTION CONTRACTOR.

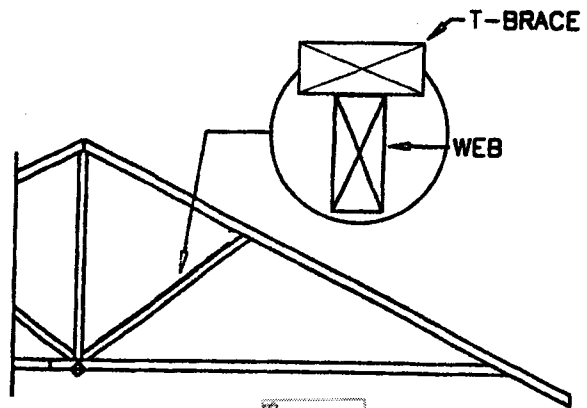

T-BRACE

THESE DETAILS APPLY TO 1.5" WIDE WOOD TRUSSES.

- USE A 2x4 T-BRACE IF THE TRUSS DESIGN SPECIFIES ONE LATERAL BRACE (MID POINT OF WEB).
- USE A 2x6 T-BRACE IF THE TRUSS DESIGN SPECIFIES TWO LATERAL BRACES (AT THE THIRD POINTS OF THE WEB).
- USE A CONTINUOUS PIECE FOR THE T-BRACE, OF THE SAME GRADE AS THE WEB AND COVERING AT LEAST 90% OF THE WEB LENGTH.
- CENTER THE T-BRACE ON THE WEB AND FASTEN WITH 10d COMMON NAILS SPACED 4" ON CENTER.

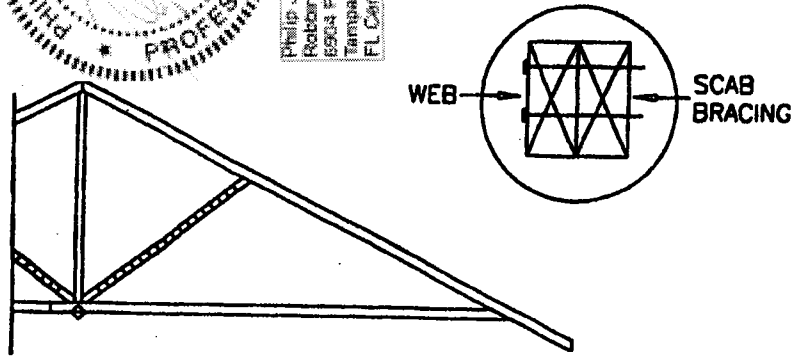
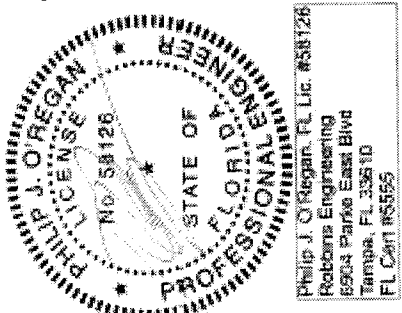

SCAB BRACE

SCAB BRACE SAME SIZE, GRADE,
 AND LENGTH AS WEB MEMBER.
 ATTACH WITH 10d NAILS @ 4" O.C.
 BRACING MATERIAL TO BE SUPPLIED
 BY ERECTION CONTRACTOR.